

OPERATING INSTRUCTIONS

AND

MAINTENANCE MANUAL

FOR THE



MODEL 10T-2M

FLUID POWERED ADDITIVE INJECTOR SYSTEM

Manufactured by

HAMMONDS TECHNICAL SERVICES, INC.

910 Rankin Rd.

Houston TX 77073

(281)999-2900

Fax: (281)847-1857

www.hammondscos.com

November 2005

Hammonds Model 10T Injection System Manual

TABLE OF CONTENTS

Special Notice to Users	3
Installation and Preparation for Startup	3-4
Installation Considerations of Bare Units	4-5
Locating the System	6-8
Additive Supply System	8-10
Additive Tank Installation	10-12
Preparation for Calibration and Startup	12-13
Calibration and Startup	13-15
Additive Chart	16
Trouble Shooting the System	16-17
Preventive Maintenance	17-19
Preventive Maintenance Schedule	20
Desiccant Dryer Instructions	20-21

Attachments:

- Charts, Test Reports, Material Certs.
- Drawings and Parts List
- System Layout
- Hydraulic Schematic
- Drive Unit Parts
- Gear Reducer Parts
- Injector Pump Parts
- Diaphragm Replacement Instructions
- Sight Flow Indicator Parts
- Calibration Device Instructions

Hammonds Model 10T Injection System Manual

SPECIAL NOTICE TO USERS

PLEASE READ CAREFULLY BEFORE INSTALLING EQUIPMENT

This additive injector system is designed to give consistent, dependable performance when operated and maintained according to manufacturer's recommendations. However, being a mechanical device, it is subject to failure from wear, human error and operating environments beyond the control of the system. Because of this fact, it is the responsibility of the operator to make certain that:

- A. The system is installed properly.
- B. The system is being operated properly.
- C. The system is actually running during product transfer.
- D. The system is checked after the transfer operation to make certain the proper

amount of additive was injected during the operation.

The performing of these checks by the operator eliminates the possibility of product not having the proper additive ratio as required. Therefore, since the manufacturer cannot be present during each transfer operation, the responsibility for checking the performance of the system is that of the operator. Should there be any questions whatsoever, the operator should consult the factory authorized distributor, or the factory directly.

DO NOT TAKE CHANCES

DO NOT GUESS

Be absolutely certain that the system is operating as it should. The user/operator carries the final responsibility to make certain the system is operating properly.

INSTALLATION AND PREPARATION FOR STARTUP

In most cases, the Hammonds fluid powered injector is shipped complete and ready to operate. The system should include appropriate fittings to suit your specific application. Flow direction is marked on additive pumps and check valves. Any and all flow restricting devices such as ON/OFF ball valves, remote panels, sight flow indicators, suction strainers or electrically controlled solenoid valves must be installed on the suction side of additive pumps.

CAUTION: Do Not Attempt To Use This Device Without Understanding And Following Proper Safety Precautions Regarding System

Grounding, Fire Safety, And Special Handling For Potentially Dangerous Additives.

Consult your Engineering Department for their specific instructions. Make certain all personnel involved with this system are thoroughly familiar with safe operating practices.

If your system has been purchased "bare," consult your equipment distributor for help in selecting hoses, fittings and other related accessories. Selection of materials compatibility, location of unit within the system, effect of the unit on the system and

Hammonds Model 10T Injection System Manual

injection point of the additive are also factors that should be discussed by factory authorized personnel. If a factory-authorized distributor is unavailable, consult the factory directly for assistance.

**HAMMONDS TECHNICAL SERVICES,
INC.
15760 West Hardy, Suite 400
Houston TX 77060-3147
Phone: (281) 999-2900
Fax: (281) 847-1857**

INSTALLATION CONSIDERATIONS OF BARE UNITS

Hammonds injection systems may be installed in a wide variety of applications, systems and operating conditions. This manual makes the assumption that the purchaser has consulted with the factory and has approval for the application and installation. If this is not the case, listed below are a few considerations that should be reviewed before installing a unit in an existing system. Hammonds offers a wide range of performance capabilities with the same unit by matching special turbine configurations and flow conditions. Make certain the manual and the unit are specifically for your application.

FLOW CONSIDERATIONS

The 10T high capacity units normally see flow rates of up to 4000 GPM. In these installations, flow may, depending on maximum GPM, be reduced slightly. As an example, a system performing at 600 GPM prior to installation, may be reduced by as much as 30 GPM, reducing the overall system performance to 570 GPM. Obviously, this minor reduction is negligible, and, in many cases, the system pressure can be adjusted to compensate for this. In no way, will the installation of a Hammonds injector overload a product pump since any minor reduction in flow results in less horsepower demand on the system.

A reduction of 30 GPM on a 600 GPM system loading a 1000 gallon tank compartment

results in an additional 5 seconds to the time required to load the compartment.

As you can see, flow rate reduction is not a concern providing the system has been properly matched to the application. If there is any doubt, consult the factory, as a standard unit not designed for the higher flows will reduce system flow considerably.

POINT OF INJECTION OF THE ADDITIVE

Some additives may adversely affect other components in the fuel system. Seals in meters and valves, filter elements and aluminum to name a few. Unlike competitive systems that slug the additive into the product at measured intervals as high as 60 gallons, the Hammonds injector does an excellent job of mixing the additive in the product as it is being injected ahead of the turbine blades. In addition, a typical unit will inject the precise amount of additive required for every one- (1) gallon of product that flows through the system. In operation, that is a continuous flow of additive that is being mixed without gaps. This even, continuous mixing eliminates slugs of concentrated additive being dumped into the system.

INSTALLATION RELATIVE TO METERS:

Hammonds injectors can be

Hammonds Model 10T Injection System Manual

installed at any point in the system. In most terminal operations, it is desirable to meter the additive. Meters, valves or strainers do not affect the system, so it can be placed wherever there is room. In aviation truck applications, it is placed up-stream of the meters, (some have two), it will precisely inject additive to the system, whether a single hose or dual hose fueling is used.

SPACE REQUIREMENTS: The system is designed with easy services in mind. The entire turbine and pump assembly can be removed from the housing without disturbing the system piping. Ample room should be reserved in the installation for this removal, if possible. Also, the operator needs to have visual access to the controls on the pump for calibration.

ON/OFF OPERATION: There are two methods for providing ON/OFF operation to the system. One is by using a remote panel that includes a special rotary valve connecting the additive tank and the injector appropriately, and the other (FOR DIAPHRAGM PUMPS ONLY) is a simple, 2-position ball valve installed in the additive supply line that connects the additive storage tank and the injector. Preferably, the valve should be located as close to the injector as

possible. Turning this valve off for a short duration does not harm the unit in any way, nor does it cause the unit to lose the prime of additive. As soon as the valve is opened, the pump immediately begins injection without any loss of ratio whatsoever.

Caution: *Do not install this On/Off valve between the injector and that point where the additive enters the fuel. Doing so will cause the unit to fail. Remember that the discharge of the injector must never be blocked.*

PLACEMENT OF THE ELECTRIC ON/OFF SOLENOID: Some systems use an electric powered on/off solenoid for remote operation of the system. When used, the ideal location for this valve is between the injector and the Sight Flow Indicator. The valve should be placed as close to the injector as possible. In terminal installation, it is not recommended that the valve be placed back at the tank, which is usually a considerable distance from the injector. As with the manual on/off valve, the solenoid valve must NEVER be placed between the injector and the point of injection.

Hammonds Model 10T Injection System Manual

LOCATING THE SYSTEM

In rack loading installations, there are usually two primary location choices for installing the system.

The first choice would be remote from the island at some point in the main product line between the product pump and where the pipe goes underground or overhead, leading to the island itself. This type installation is usually used in cases where all the product handled by the island will be treated. Although the additive can be turned off, if two loading arms on the island are being used simultaneously, it is not possible to isolate one and not the other for injection.

INJECTOR LOCATION FOR OFF-ISLAND INSTALLATION

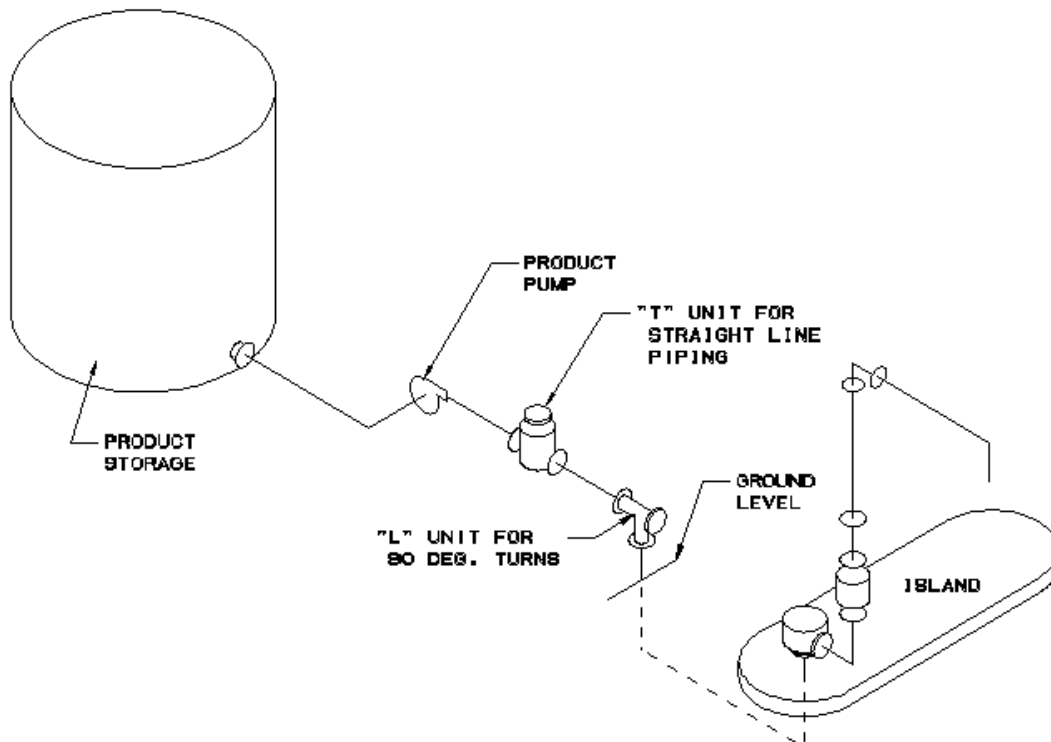

The injector should not be located between the product pump and the product storage tank.

In remote island installations such as illustrated above, 10T can be used in either horizontal or vertical straight runs of pipe.

The other option for basic location is on the island itself. In this installation, a unit is usually placed on each of the loading arms, providing for the selective injection of any combination. The unit may be installed at any point from where the pipe exits the ground to where the swivel arm begins for the hose drop. This location offers versatility in that a single injector can be shared by up

Hammonds Model 10T Injection System Manual

to four (4) separate users, injecting different additives on demand. There is almost always a convenient “spot” to install the system, either in a 90° elbow or in a short run of straight-line pipe.

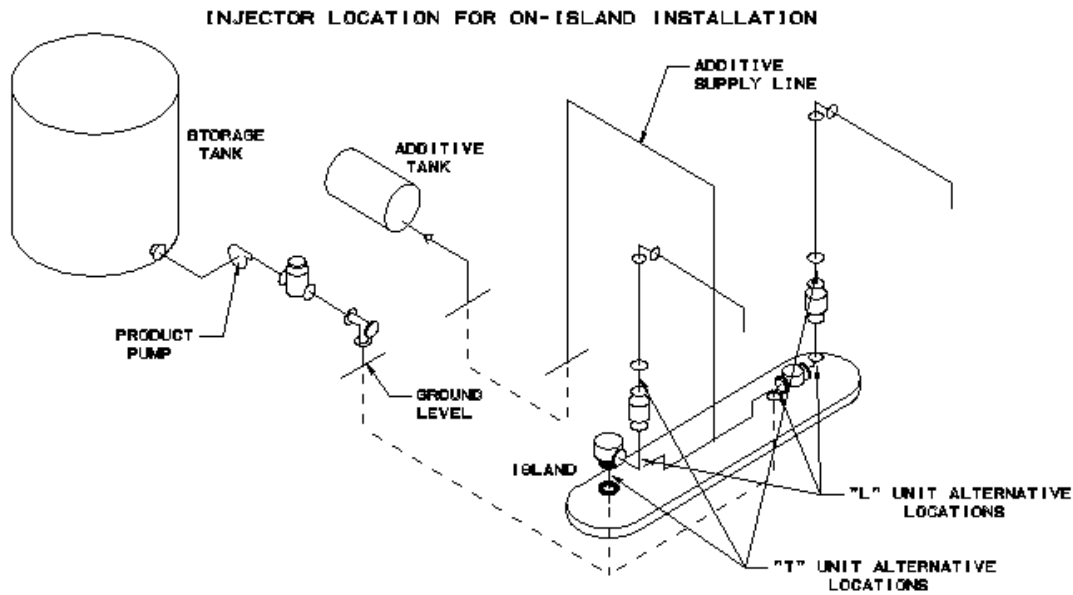

Location of the injector at the island is usually handy to existing wiring conduits for card controls, allowing for easy installation of the on/off solenoid. Units can be configured for horizontal or vertical installation.

CHOOSING THE SPOT FOR INSTALLATION OF THE UNIT ON THE ISLAND

Most island loading arms will present at least two and sometimes three mounting options. Consideration should be given to serviceability and traffic of personnel and equipment such as swinging hoses.

Hammonds Model 10T Injection System Manual

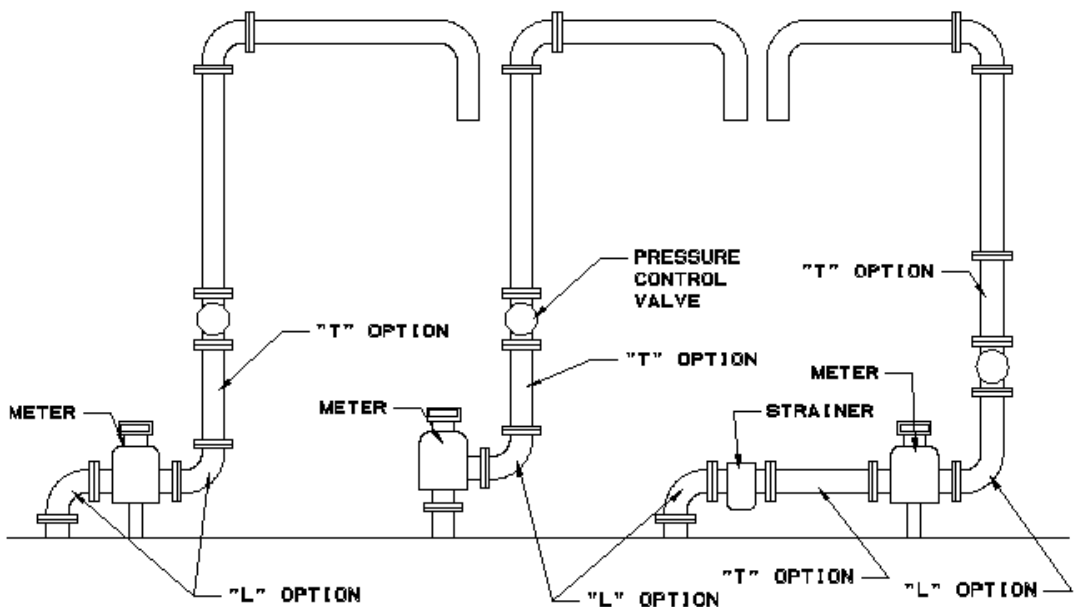

ADDITIVE SUPPLY SYSTEM

The illustration below identifies the basic components necessary for a complete additive supply system. Study the information provided for each component, as each part plays a vital role in the overall performance of the system.

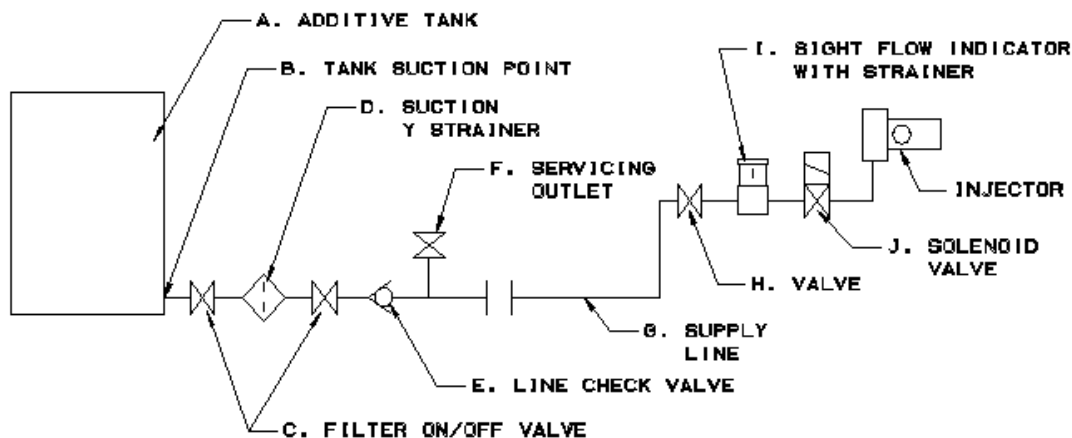

A. THE ADDITIVE TANK: Additive tanks should be constructed of materials compatible with the additive. Tanks should be new and free from scale, rust and corrosion. Any loose surface material inside the tank will fall into suspension and contaminate the additive after startup. Care should be taken to

prevent sandblast sand from entering the tank during the manufacturing process. If water is used for testing, the tank should be dried internally to prevent the formation of rust.

B. TANK SUCTION POINT: Suction should never be taken from the very bottom of

Hammonds Model 10T Injection System Manual

the tank. Should foreign material of any kind be present, the line will become plugged, causing

either failure or erratic performance of the system. Remember, there are components in every additive system that are sensitive to contamination. Suction should be taken at least 1" off the bottom of the tank to prevent the introduction of foreign sediments off the bottom.

C. FILTER ON/OFF VALVE: A full opening ball valve of at least the diameter of the additive supply line should be placed on either side of the suction Y strainer. Two valves are necessary in order to clean the strainer without losing the entire line full of additive. This will prevent having to re-prime the system each time the strainer is cleaned.

D. SUCTION Y STRAINER: A large Y type strainer with a screen opening of not more than 50 is ideal for taking most harmful particles from the additive supply. Any smaller mesh will cause excessive friction loss. If the openings are too large, the strainer will do little to protect the system.

E. SUCTION LINE CHECK VALVE:
This suction line check valve is used to provide additional insurance that the primed line will not drain back between uses. If the additive supply line is properly installed without leaks, it will remain full even when not in use. This line check valve is suggested as an extra precaution to prevent loss of system prime. The valve should be made of a material compatible with the additive, and have a "feather light" opening pressure. The valve should be a ball type with a synthetic material that is very light, preferably with no spring. The gravity of the material will seat the ball. Consult the factory if there is any question regarding the proper valve for this application.

F. SERVICING OUTLET: The service outlet provides a means for operating a manual pump in the additive supply line. The pump can be connected and used for purging air from the line while priming. Although this is an option, the factory strongly recommends the accessory for easy startup and service. A simple tee and on/off valve is used for this purpose.

G. ADDITIVE SUPPLY LINE: The size of the delivery line to the injector is important when long distances are involved. Use the following chart for determining line size.

0 - 500 PPM up to 25'	1/2"
25 to 50'	3/4"
50 to 100'	1"
Over 1000 PPM up to 25'	3/4"
25 to 50'	1"
50 to 100'	1 1/4"

The above lines will supply up to four (4) injectors simultaneously at the rates given. Consult the factory for greater requirements.

H. SIGHT FLOW/STRAINER VALVE:
This valve is also a full opening ball valve that is used to isolate the additive line when cleaning the strainer in the Sight Flow Indicator.

I. SIGHT FLOW INDICATOR/SUCTION STRAINER: This strainer is used to provide indication of the system's operation, as well as add extra protection for the solenoid valve from trash and contamination. When properly installed, this indicator will give the operator proof that the system is operating properly.

J. SOLENOID VALVE: This valve is provided for the remote operation of the system. It is important that the valve is a

Hammonds Model 10T Injection System Manual

direct acting type that requires no pressure from the line in which it controls. The materials of the valve body and the elastomers are extremely important as any reaction with the additive can cause failures. Consult the factory to make certain that the valve and trim

materials are compatible. Also, make certain that the orifice in the valve is at least 7/16", with 5/8" being ideal. Any restriction in this orifice will cause the system to work harder to perform the given ratio of injection.

ADDITIVE TANK INSTALLATION

Placement of the additive tank and related supply lines relative to the injector is critical to performance of any additive system. The following illustrations will provide information regarding the various types of tank installations and their connection to the additive injectors. Hammonds injectors offer the greatest flexibility in tank and supply line installation of any additive injection system on the market. Since no pumps or feed mechanisms are necessary, installation goes faster and at less cost. The choice of appropriate components and pipe sizes, along with leak-free installation, will determine if the system works properly and consistently.

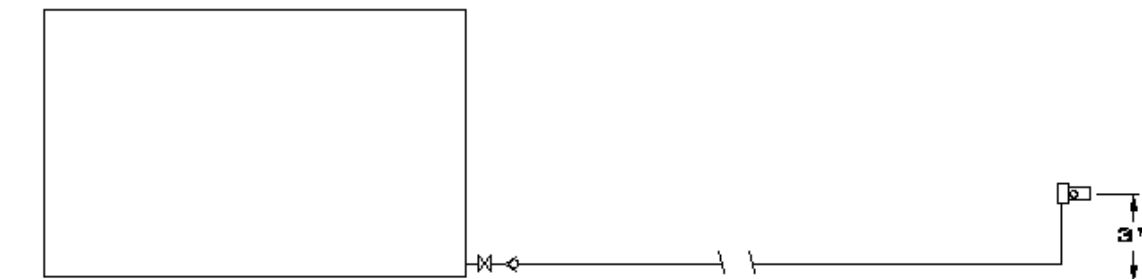

OPTION 1 - ABOVE GROUND TANK, ABOVE GROUND DELIVERY LINES

This installation calls for both the tank and the supply lines to be above ground. The bottom of the tank is very close to the ground, and the injector is approximately 3' above ground. Using a 4' diameter tank, this would provide a variable net suction head to the injector of +1' when the tank is full to a worst condition of a -3' when the tank is almost empty. A Y type strainer should be located at the tank. A full opening ball valve located on each side of the strainer, with a light action (less than 1/2 PSI) check valve installed to assist in holding the prime. Install a ball valve just upstream of the Sight Flow Indicator, and if one is to be used, install the solenoid-operated valve between the Sight Flow Indicator and the injector. Use the table listed in the previous section for selection of pipe diameter.

Hammonds Model 10T Injection System Manual

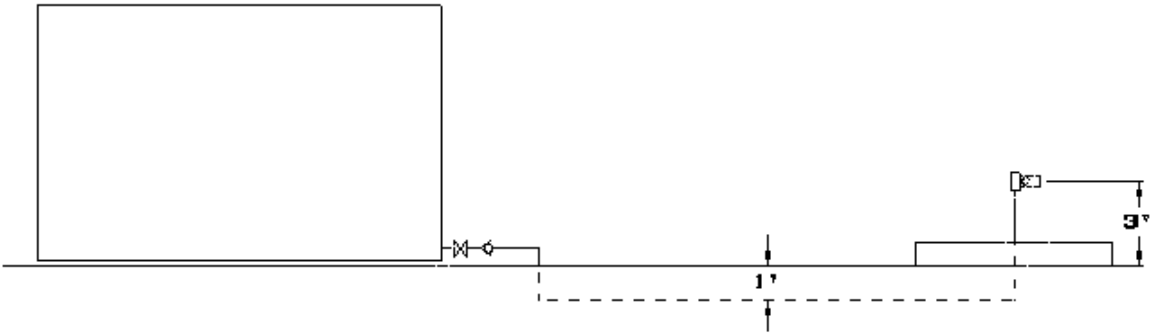

OPTION 2 - ABOVE GROUND TANK, BELOW GROUND DELIVERY LINES

This option is basically the same as that in Option 1. The effect of burying lines below the ground level does not affect final suction conditions since the head gained in going below ground level offsets the additional lift at the injector end. It is necessary to make certain on initial startup and priming of the system that all air is removed from the supply lines and the various components.

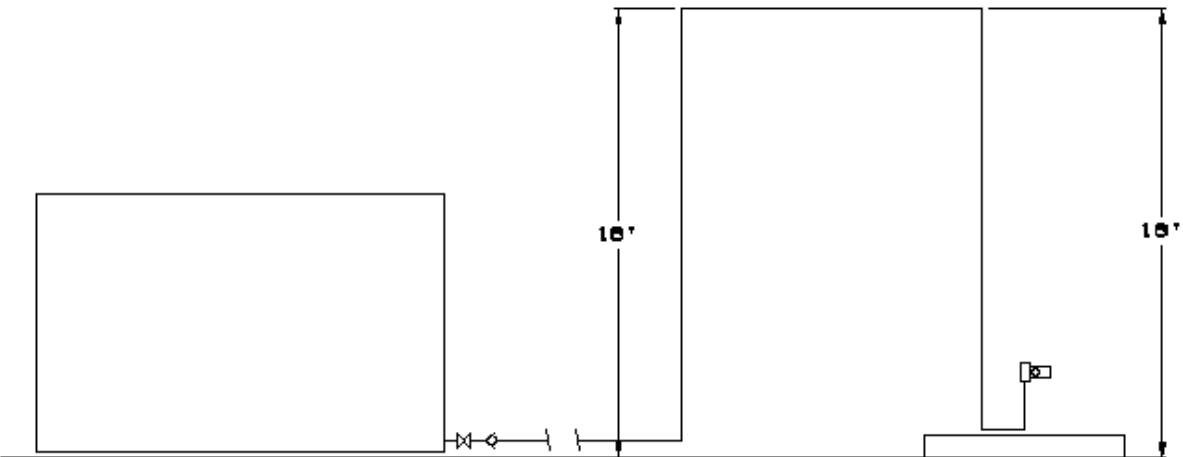

OPTION 3 - ABOVE GROUND TANK WITH HIGH CLEARANCE OBSTACLE

This application for a non-pressurized additive system is difficult to achieve in the real world because fittings and check valves notoriously leak. . **This is not recommended.** If equipment is installed in this manner it will void the factory warranty.

Hammonds Model 10T Injection System Manual

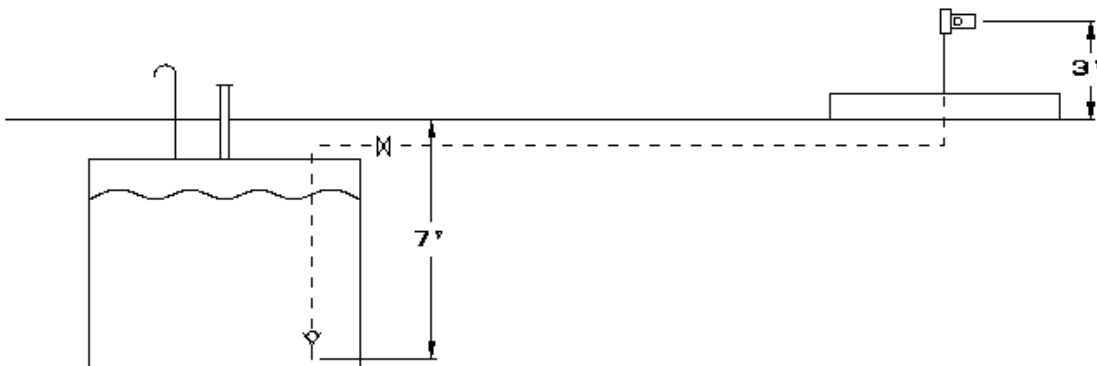

OPTION 4 - BELOW GROUND TANK, BELOW GROUND LINES

This is the most difficult application for a non-pressurized additive supply. In this case, the pump must overcome a negative lift equal to the total distance between the bottom of the tank and the injector above ground.

This is not recommended because fittings and check valves leak. If equipment is installed in this manner it will void the factory warranty.

PREPARATION FOR CALIBRATION AND STARTUP

Before attempting to start the system or make calibration, please read the following information carefully.

During startup and calibration, you will be bleeding the system of air, collecting samples of additive during calibration, and checking for possible leaks throughout the system. Provisions should be made for cleanup of spilled fluid. You will have some losses during these procedures. If the additive being handled is flammable, fire safety precautions should be taken. Since the installation may also be tested at this time, extreme caution should be used in checking for leaks of the mainline. If you wish to set the system up for leak-free testing and calibration with zero spillage, please consult the factory for help in doing so. We will be glad to suggest necessary parts and procedures.

A WORD ABOUT ADDITIVES

Most additives being used in fuels today have at least some degree of toxicity. Many are very dangerous. Extreme caution should be taken in handling additives. Remember, the additive is placed under pressure when being injected into the line, and when collecting samples during calibration, some spillage can occur. Be careful, wear protective clothing including eye protection. Be sure you have facilities to wash off any additive that may come in contact with your skin. Read all factory safety precautions and follow them to the letter.

Hammonds Model 10T Injection System Manual

HERE IS WHAT YOU WILL NEED:

- Appropriate safety protection equipment
- Eye protection in the form of safety goggles
- An assortment of wrenches that fit the various fittings on the system. Note: two (2) 10" Crescent wrenches will normally take care of any adjustments to fittings you may have to make (one to hold the fitting, and one to hold the adjacent fitting.).
- Some clean rags for cleanup of spilled material.
- A marked graduated glass bottle that is marked in either CC's or ounces. (At least 16 ounces)
- A stop watch.
- A means of determining the flow rate of the main system.
- A small pocket calculator is helpful for convenience.

- A clipboard is helpful with pad of paper.
- *At Least One, And Preferably Two Extra Helpers.*
- A large container to collect the output of the pump while you are not actually calibrating the system.

REMEMBER: Any pumping system varies with temperature and fluid being pumped. The system also changes as parts of the pump wear.

No two systems will ever perform exactly the same. For this reason, the procedures given for calibration are general in nature. Obviously, it is impossible to provide a graph or table that would be absolutely accurate in every case. With that in mind, all tables and graphs should be used as general guidelines. Remember, the calculated, timed and measured output that you gather is absolute. Trust your figures and your calculations.

CALIBRATION AND STARTUP

IF YOUR INJECTOR SYSTEM IS EQUIPED WITH CALIBRATION GAUGES, FOLLOW THE INSTRUCTIONS FOR THEIR USE IN THE BACK OF THIS MANUAL.

PROPER ADDITIVE INJECTION RATIOS

Although volumetric calibration at atmospheric pressure will bring you within an acceptable range of additive injection, the only true evaluation for proper ratio is the ASTM D-5006 evaluation for fuel system ice inhibitor (FSII). Do not depend on volumetric calibration to ensure on-spec performance because line pressures can vary and additive injector parts wear over time. Contact Hammonds Fuel Additives, Inc. for

supply of quality fuel system ice inhibitor and fuel testing procedures.

Please Follow These Steps In Their Given Order.

Read Them Over Carefully Before Starting, Then Follow Them To The Letter.

If There Is Any Part Of The Procedure That Is Not Clear, Consult Your Factory Representative Or The Factory Directly.

1. Make certain the additive tank is full of the proper additive.
2. Open the suction valve between the tank and the pump. This valve may be located at any point between the additive tank and the injector.

Hammonds Model 10T Injection System Manual

3. If the system has been calibrated at the factory at a particular level close to what is desired, you may only have to make minor adjustments. If this is the case, go directly to Step 6.

4. If you are starting from scratch in your calibration and adjustment, loosen the stroke adjustment locking screws located on the bottom of the pump body. This will allow the stroke adjustment to be moved.

5. Adjust the stroke adjustment knobs located on the pump body to approximately 50%. CAUTION: Do not turn this adjustment with excessive force. If they are difficult to adjust, simply rotate the shaft coupling just ahead of the pump as you make the adjustment. You will find this makes the adjustment much easier.

6. Lock the stroke adjustment locking screws down firmly.

7. Set the calibration valve in the bleed or "calibration position."

8. Make certain all product connections going to and from the system are in their proper, locked position to ensure safe, leak free flow of product through the turbine. Check the flow direction arrows located on the turbine housing to ensure that the system is installed properly.

9. At this point, consider the information you will have to gather during the next few steps of the calibration process.

A. What will the flow rate through the unit be?

B. What is the length of time that the calibration will cover?

C. What is the amount of additive in ounces or cc's that you will need to collect, based on the time duration of the calibration?

You should have the answer to all these questions during, or by the end of your first calibration trial run. If you alone can do it all, fine; however, it is suggested that you have an assistant give you that information as it will be needed to determine whether the system needs to be increased or decreased in output.

10. Before starting the product supply through the system, make certain everyone understands that you will run the system for, let's say, one (1) minute. Even shorter runs are fine, especially if you are running at high flow rates.

11. Place the measured graduate under the calibration tube. Put on your eye protection!

12. At the command of the timekeeper, or that person watching the flow meter, start the product pumps.

13. Give the system a few seconds to gather momentum and flow through the turbine. Notice if the turbine is turning. The coupling between the pump and the turbine housing should be spinning. You may not be able to see the coupling on some models, however, you see the shaft. On enclosed systems, there may be a 1/2" pipe plug that can be removed on the side of the gearcase mounting in order to view the shaft and coupling.

14. If the pump is being started up for the first time, it will take a few seconds to prime itself and begin discharging fluid from the calibration tube. Is your eye protection on? If not, PUT IT ON NOW.

15. As soon as the pump begins discharging a clear, air free stream of fluid from the calibration tube, you will be ready to stop the system and begin your calibration. At this point, the system is primed.

Hammonds Model 10T Injection System Manual

- Hammonds recommends using the pressure simulating calibration device shown in the back of this manual.

16. You will now prepare to make your first actual calibration run. Notice the setting on the flow meter, set your stopwatch at zero, and empty your collected additive back into the tank, putting the bottle back under the calibration tube.

17. When everyone is ready, start the system again. Stop it at the decided time interval or meter reading. Calculate the amount of product that traveled through the system. Measure the amount of additive gathered, and record the amount of elapsed time.

18. It will be at this time that you will have to calculate how much additive should have collected for the amount of fuel that the system pumped. This, of course, depends upon the ratio that is required. You may be a whiz at numbers and do this in your head; however, for the rest of us, it takes a little longer. If you know for sure how to arrive at these figures, you can stop right here. If not, the following example is the easiest way of explaining the procedure without getting too complicated. It is not the only way....just one way. Use it if you like.

Example condition: Amount of product pumped: 500 gallons

Ratio of additive desired: 250 PPM (parts per million)

It is assumed that the operator will know how much product is being pumped through the

system in a given length of time. If, for example, you have a meter that registers the flow in gallons, you simply record the gallons at the beginning of the timed run, and then again at the end of the run. If you ran for one (1) minute, you simply subtract the beginning number on the meter from the number registered after the run. This will give you the gallons per minute (GPM). Having to make this calculation is the only reason for timing the run. You can accomplish the same result by just watching the meter and stopping the system when you have totaled the desired amount of gallons through the system. In any case, you must know the amount of product passing through the system before calibration can begin.

First, change the gallons pumped into ounces by multiplying 500 x 128. The answer is 64,000 ounces. (128 oz. To a gallon)

Second, divide 64,000 by 1,000,000. The answer is .06. Since you are dealing in 1/1,000,000 of the total for your ratio, you must find out what 1/1,000,000 of the 500 gallons is.

Third, multiply the .06 x 250 (for 250 PPM ratio). The answer is 15 ounces.

So, you should collect 15 ounces of additive for every 500 gallons of fuel pumped.

These are all large, round numbers. You may, for example, only be running at 100 GPM, not 500. Use the same procedure, just change the numbers to fit your application.

Hammonds Model 10T Injection System Manual

ADDITIVE CHART

GALLONS	135 PPM	270 PPM	1000 PPM
100	1.7 OZ.	3.4 OZ.	12.8 OZ.
200	3.4 OZ.	6.9 OZ.	25.6 OZ.
400	6.9 OZ.	13.8 OZ.	51.2 OZ.
500	8.6 OZ.	17.2 OZ.	64.0 OZ.
700	12.0 OZ.	24.0 OZ.	89.6 OZ.
1000	17.2 OZ.	34.5 OZ.	128.0 OZ.

TROUBLESHOOTING THE SYSTEM

The following conditions are given as a means of troubleshooting the system. Each condition lists a number of possible causes. In most cases, trouble can be solved by the use of this section. Please read it carefully before attempting repairs, or making changes in the system.

THE TURBINE IS NOT TURNING

- A. Insufficient flow to turn the turbine. A minimum of about 300 GPM must be present to start the system. 350 GPM is the minimum for normal calibrated operation.
- B. A rag or some other object is jammed in the line, preventing the turbine from turning.
- C. A diverter valve is blocked downstream of the system, blocking the fuel flow through the system.
- D. A defueling valve is left open on a truck or hydrant system, starving the turbine for product flow.
- E. The pump and turbine have been knocked out of alignment during shipment or installation, causing a binding of the coupling.

THE TURBINE IS TURNING AND PUMP IS RUNNING, BUT WITH NO OUTPUT

- A. Pump is airlocked. In some cases where there is a very long line running from the injector head and the point of injection into the system, there is sufficient air volume to cause the pump to act as a compressor. It is not able to open the valves throughout the system and, therefore, cannot pull a suction of fluid to the pump. Crack the fitting ferrule nut on the discharge side of the calibration valve and allow it to remain open until the pump begins pumping. This is rare, but can happen in some cases of unusual installations.
- B. One or more of the suction or discharge check valves is not working. While the pump is running, tap on the side of the valves, one at a time. This will generally jar them loose. The balls are very small, and will sometimes become stuck from the residual test fluid left in the pump from the factory. After the valve is loosened and has a supply of fluid, it will not usually stick again.
- C. The pump is not getting additive. Check the valve between the pump and the tank. Check all connections in the line between the pump and the tank.
- D. The vent on the tank is not open, causing the pump to pull a vacuum. Open the vent. Check to see if the cap has been

Hammonds Model 10T Injection System Manual

removed from the dryer cartridge, if so equipped.

E. The pump stroke is set at zero. Check to see if the locking screws have been left

loose, allowing the adjustment knobs to rotate to 0.

F. The additive tank is empty...don't laugh, it happens.

PREVENTATIVE MAINTENANCE

1. Check pump gearbox oil level monthly. To check the pump gearbox oil level, remove the plug on the side of the gearbox (1/8" Allen head pipe plug) that is even with the output shaft of the gearcase. Oil should be filled to this level. To add oil, remove vented cap on top of gearbox. Refill with Mobil Synthetic All-temperature Gear Oil, #SHC 626. Do not overfill as oil will boil out of the vent if level is too high. Fill until oil comes out the side port. Overfilling will overheat the unit and reduce injector output.

2. Make certain to use only clean, fresh additive that has been stored in a sealed drum. Most additives are moisture sensitive. Some will form heavy crystals if allowed to accumulate moisture. These crystals will stop the pump in very short order, if not cause calibration to be changed due to clogging of valves and other parts.

3. Check the additive filter screen at least every month, more often if there is an indication of possible contamination.

4. Check the system for leaks at every use. This is an extremely important procedure since some additives are flammable, caustic, and corrosive and may have environmental impact if a spill occurs.

5. Check for leaks at the seal that is located at the exit point of the turbine output shaft as it leaves the turbine housing. This should be at each operation. Leakage at this

point usually indicates the mechanical seal inside the turbine housing is leaking. A leak here will usually indicate fuel, and is not only a possible fire hazard, fuel in the bearings of the turbine will quickly wash away lubricant and cause damage to the gearbox.

6. Check the fittings for leakage around the suction filter, if one is used on the pump. Check this fitting each time the filter is changed or cleaned. This would apply to top and bottom of the glass tube used in the Suction Sight Flow Indicator. Make certain there are no leaks in the suction line. A very small leak will either change the operation of the pump, or prevent it from operating altogether.

7. Visually check around the pump head to make certain there is no leaking of additive around the fluid ends. If there is, check the tightness of the head bolts. These screws must be tightened to 40 inch pounds. Under tightening will allow leaks and the diaphragm to work free, reducing the output of the fluid end. Overtightening will damage the diaphragm. An additive leak that appears to be coming from inside the pump power frame under the stroke mechanism, usually indicates a ruptured diaphragm.

8. Pump diaphragms require replacement at different intervals, depending on the total hours of service, the speed of the particular installation and the percent of stroke being utilized. As an example, a system that

Hammonds Model 10T Injection System Manual

operates eight hours every day is considered continuous duty. If the system is operating at above 120 RPM pump speed, it is considered severe, and finally, if the pump setting is greater than 50% stroke, the diaphragms will experience greater fatigue and, therefore fail sooner than one that is set at 10 - 25% stroke.

Depending on the operating conditions (duty cycle, speed, and % of stroke and pressure), diaphragms can be expected to last from 6 - 18 months. It is recommended that critical duty installations begin initial service by checking the diaphragms after 6 months. Normally, checking only one of the diaphragms will give an indication of the condition of others in the system. Examine the diaphragm for wear. If it is in good condition, perform the next examination following nine months of service. If the condition remains good, examine again after twelve months. Check for signs of breaks in the Teflon surface, cracking or swelling of the rubber backing and failure of the fastener in the rear of the diaphragm. White crazing on the surface of the Teflon face is normal. If any signs of swelling or deformity of the Teflon is seen, the diaphragm must be replaced. Remember, only the Teflon face is resistant to the additive. The rubber backing will soon deteriorate after the Teflon face is broken and leaks additive to the reinforced back.

As a general rule, diaphragms should be replaced every twelve months. Careful monitoring of your installation may reduce or extend that period. You should establish a maintenance schedule that gives reasonable life, without risking unscheduled failures.

9. Check grease around the eccentric drive bearing in the pump every six months. Use a heavy, waterproof grease. A little common sense here is important. The bearing needs enough lubricant to keep the surface of the bearing and the face of the crosshead coated.

Excessive amounts only attract dirt and make visual inspection of the various parts difficult.

10. Check the eccentric drive bearing for tightness every 30 days. Replace the bearing if there is excessive looseness in between the inner and outer race of the bearing. Make certain there is no looseness felt between the bearing and the output shaft of the gearbox.

11. Visually check the stroke adjustment parts of each pump every 30 days. These parts are held in by a series of small screws. If these fasteners are allowed to work loose, the parts soon fail. Movement in the stroke adjustment knob and the stroke locking screw during operation will indicate this condition. If any movement is observed in these parts, check closer for looseness. Thread compound must be used, along with appropriate torque settings on these fasteners.

12. All stroke adjustment parts of each pump fluid end will eventually need replacement. Again, this will depend on the severity of service. As a general rule of thumb, a complete rebuild, including the cross head, cross head wear strips, stroke adjustment cam and power frame cover, should be performed during this major maintenance. Large fluid ends as used in the "L" pump heads generally create more wear on these parts, and should, therefore, be checked regularly to establish a reasonable maintenance schedule.

13. The 10T turbine should be removed from the line, disassembled and inspected at the following intervals.

Total Operating Time Based on Daily Service Averages

0-4 hours	5-8 hours	8+ hours
24 months	12 months	8 months

Hammonds Model 10T Injection System Manual

As with injection pumps, the inspection of one unit will provide a good indication of general wear where multiple unit installations are involved. There are only four parts to inspect; the mechanical seal, two sealed shaft bearings and the oil seal where the turbine shaft exits the housing.

Mechanical Seal: A mechanical seal is normally serviceable for many years. Be extremely careful as you disassemble, inspect and reassemble the seal. The smallest scratch or particle of dirt left on the seal face will cause it to leak. The seal should be replaced, if at all possible.

Shaft Bearings: These bearings are sealed from the factory. Some 10T turbines have a grease fitting to allow external lubrication. Grease that is introduced through the zerk is only beneficial if the bearing has lost its seal and will accept grease. Excessive greasing will only contaminate the mechanical

seal and eventually escape through the vent hold in the turbine housing. Bearings should be checked for excessive tolerance between the inner and outer race. If bearings with excessive wear remain in the system, the turbine shaft will move excessively and cause the mechanical seal to leak. Bearings are inexpensive, replace if possible.

Shaft Oil Seal: This lip seal is located on the turbine shaft as it exits the turbine housing. Its primary purpose is to keep rainwater and dust out of the turbine housing. During inspection of the shaft, if moisture is indicated in the turbine housing, or if the shaft has any rust present, the seal must be replaced. Make certain the shaft is clean and free of any corrosion and rust before reinstallation of, preferably, a new seal. Steel wool can be used to remove any minor corrosion. Since the shaft is stainless steel, there should be very little corrosion present.

Hammonds Model 10T Injection System Manual

PREVENTATIVE MAINTENANCE SCHEDULE

NOTE: It is important to read the previous pages on preventative maintenance. These intervals are general, and may vary according to individual applications and severity of service.

SERVICE FUNCTION	0-4 HRS DAILY	5-8 HRS DAILY	8+HRS DAILY
Check pump gear oil level	Monthly	Monthly	Monthly
Check additive filter screen	Monthly	Monthly	Monthly
Check system for additive/fuel leaks	Daily	Daily	Daily
Inspect diaphragms/plunger seals	12 Months	6 Months	3 Months
Replace diaphragms/plunger seals	12 Months	As needed	As needed
Check eccentric bearing grease	6 Months	3 Months	Monthly
Check stroke adjustment parts for looseness	Monthly	Monthly	Monthly
Replace stroke adjustment parts	24 Months	As needed	As needed
Disassemble and inspect turbine housing and internal parts	24 Months	12 Months	8 Months
Grease turbine...use zirk fitting below gear reducer	12 Months	6 Months	3 Months

DESICCANT DRYER

Your Hammonds additive system may include either a custom additive tank, or one of several Sight Flow Indicators. Both custom tanks and the 5-SF and 55-SF Sight Flow Indicator come equipped with a desiccant dryer cartridge. These units come in several different sizes.

Most systems come equipped with the standard 3/4" cartridge. This unit is attached to the tank or Sight Flow Indicator via a short length of black rubber hose. The cartridge has a housing constructed of a clear poly material and is filled with a blue colored desiccant crystal. All these units are shipped from the

factory with a small yellow cap on the unattached end of the cartridge.

Some systems may come equipped with a large canister measuring approximately 2" diameter and 8 - 10" in length. These units perform the same function, just on a larger scale. Due to their greater capacity, they last longer between service. These units are sealed from the factory by a small, yellow plastic plug, which is located either on the bottom, or one side of the canister.

The purpose of all desiccant dryers is simply to remove moisture from the air as the

Hammonds Model 10T Injection System Manual

system breathes. All tanks or portable sources of additive supply must be vented to atmosphere in order for the injector to operate. If moisture in this venting air is not removed, some additives are either ruined, or seriously damaged. Fizzy®, for example, is designed to seek out water in a fluid. So, when enough moisture is absorbed into the container, the Fizzy® is diluted and at some point will be ruined. Biobor® JF, an anti-fungal material, will form crystals in the presence of moisture and not only perform unsatisfactorily as an additive, but will stop up pumps and lines as well.

The following instructions apply to all desiccant cartridges.

A. Remove the yellow cap or plug when the system is placed into service.

B. Observe the color of the desiccant. The original color is blue. As moisture is absorbed, the color will change to pink. When the cartridge is completely pink, it should either have its contents removed, dried and replaced, or the entire unit replaced. NOTE: The contents can be placed on a pan, and baked in a conventional oven until the moisture has been removed. When the color blue returns, the material is again ready for service.

Color change and cartridge life is totally dependent on humidity. The more moist the air, the shorter the life. Keeping it dry is especially important if additive is not consumed rapidly. Check daily, and service as needed.

Hammonds Model 10T Injection System Manual

10T-2M 300#RF ANSI INJECTOR SYSTEM

- A. Spec sheet for the following:
 - a. Mechanical seal: Not available
 - b. Gear reducer: Available
 - c. Calibration column: Available

- B. Bill of material:
 - a. 10T Driver: Available
 - b. 2M pump: Available
 - c. Mechanical seal: Not available
 - d. Gear reducer: Available
 - e. Calibration column: Available

- C. 2 Yr. Spare parts:
 - a. 10T Driver: Available
 - b. 2M pump: Available
 - c. Mechanical seal: Not available
 - d. Gear reducer: Available
 - e. Calibration column: Available

Hammonds Model 10T Injection System Manual

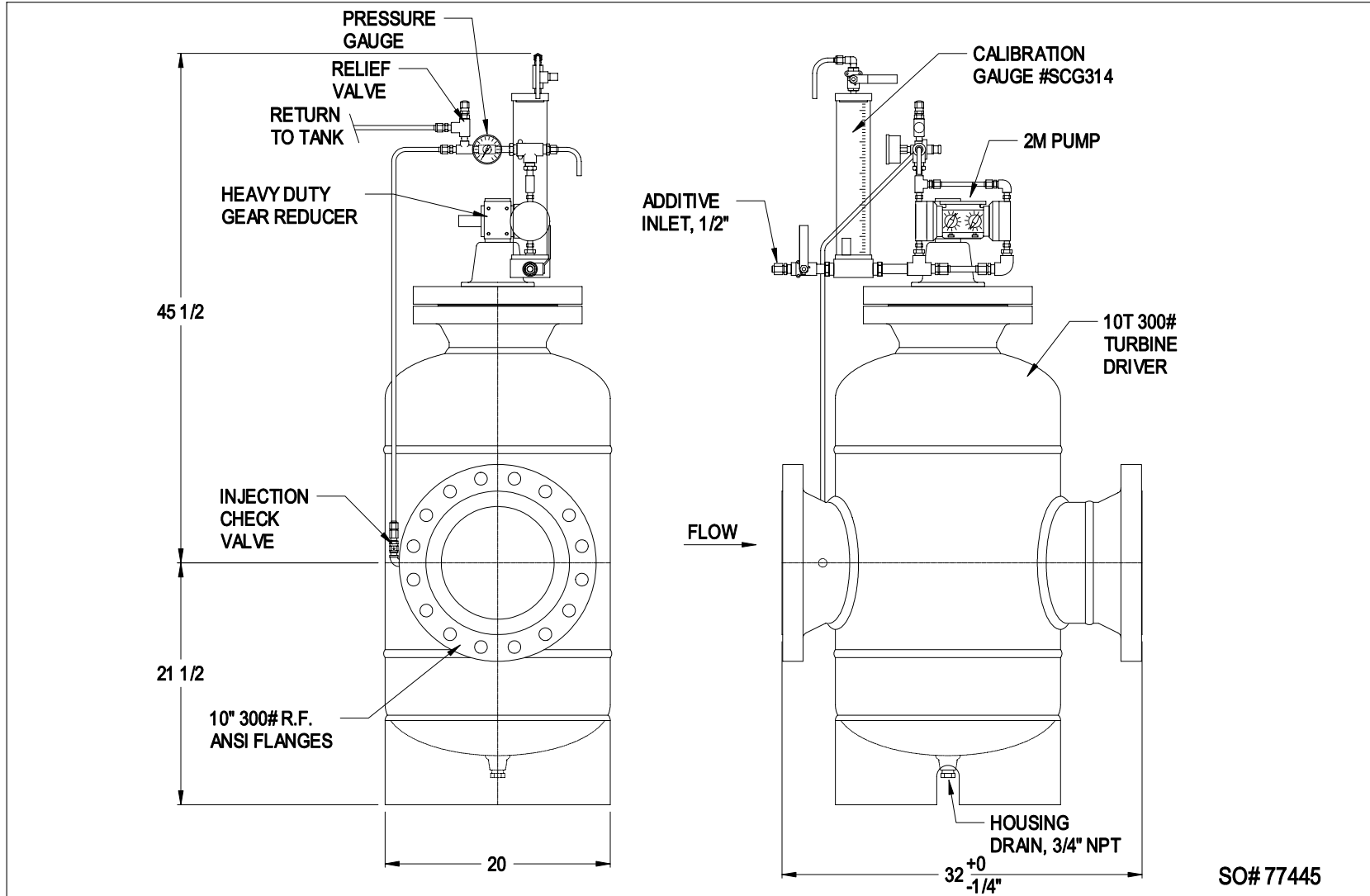

<table border="1" style="width: 100%; border-collapse: collapse;"> <tr> <th>DRAWING</th> <th>LEVELS</th> <th>VIEW</th> </tr> <tr> <td>10T</td> <td>147-149</td> <td>I</td> </tr> </table>				DRAWING	LEVELS	VIEW	10T	147-149	I	<p>*TOLERANCES* ALL DIMENSIONS ARE IN INCHES UNLESS OTHERWISE SPECIFIED.</p> <p>*TOL. DECIMALS: .XXX= +/- .005 .XX= +/- .015 .X= +/- .030 FRAC = +/- 1/16</p>		<p>*TOL. ANGLES: +/- .5 DEGREES</p>		<p>*CONCENTRICITY: .005 T.I.R.</p>		<p>*REMOVE BURRS AND BREAK EDGES .005 MIN.</p>		<p>THIS PRINT IS CONFIDENTIAL AND IS THE PROPERTY OF HAMMONDS TECHNICAL SERVICES</p>		<p>HAMMONDS TECHNICAL SERVICES, INC.</p>	
				DRAWING	LEVELS	VIEW															
10T	147-149	I																			
<p>APPROVED: [Signature]</p>		<p>DATE: 11/22/06</p>		<p>SCALE: NTS</p>		<p>DRAWING TITLE: HAMMONDS MODEL 10T 42M</p>		<p>APPROVED PART NUMBER: -PD-</p>		<p>DRAWN BY: SS</p>											
<p>NO. REVISION</p>		<p>DATE</p>		<p>BY</p>		<p>APPROV</p>		<p>FROM SER# DATE TO SER# DATE</p>		<p>300#</p>		<p>RF FLANGES</p>									

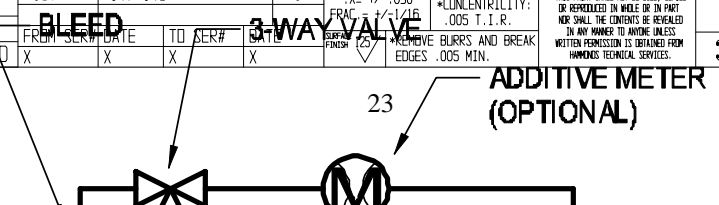

<p>HAMMONDS MODEL 10T 42M</p>	
<p>300#</p>	<p>RF FLANGES</p>
<p>600</p>	<p>6T</p>
<p>800</p>	<p>8T</p>
<p>1000</p>	<p>10T</p>
<p>1400</p>	<p>12T</p>
<p>1600</p>	
<p>2000</p>	

DRAWING NUMBER: 5499

Hammonds Model 10T Injection System Manual

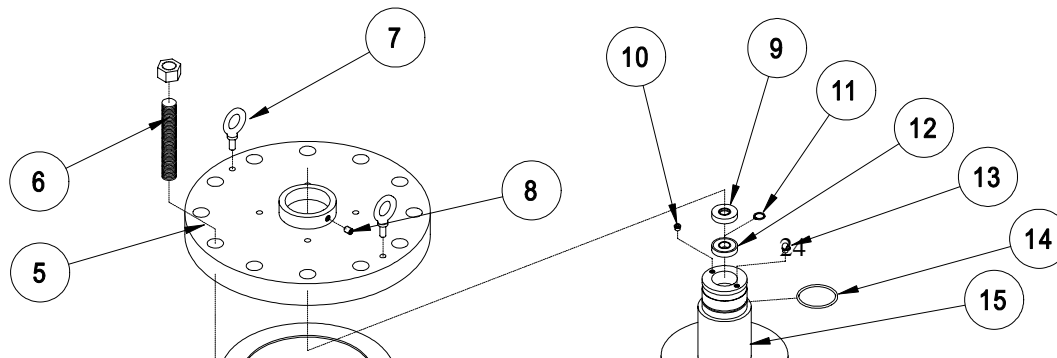

ITEM	PART NO.	QTY.	DESCRIPTION
1	142122	1	10T HOUSING...300#
2	271249	1	3/4" PIPE PLUG
3	271139	1	8" RING GASKET
5	142099	1	FLANGE 8T/10T...300#
6	882954	12	7/8 x 5 1/2" STUD W/NUTS
7	101394	2	LIFT EYE, FLANGE
8	881290	2	3/8-16 x 3/8" SET SCREW
9	883276	1	GREASE SEAL
10	231065	1	GREASE VENT, 1/8" NPT
11	883277	1	SNAP RING
12	141008	1	BEARING
13	882893	1	GREASE FITTING, 90 DEG.
14	883278	1	O-RING, VITON
15	142109	1	BEARING HOUSING
16			
17			

Hammonds Model 10T Injection System Manual

NOTE:
FOR DUAL
PUMP DRIVE...
DOUBLE QTYS.
OF PARTS
MARKED *

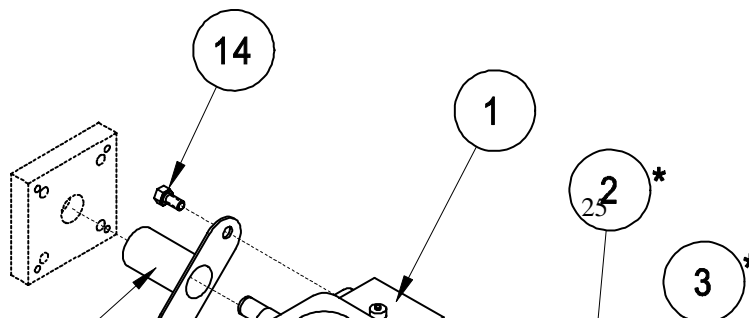

ITEM	PART NO.	QTY.	DESCRIPTION
1	882939	1	5:1 REDUCER
	882940	1	10:1 REDUCER
	882941	1	15:1 REDUCER
	882942	1	20:1 REDUCER
	882943	1	30:1 REDUCER
	882944	1	40:1 REDUCER
	882945	1	50:1 REDUCER
	882946	1	60:1 REDUCER
* 2	882010	1	PUMP ADAPTER PLATE
* 3	881059	4	SCREW, 1/4-20 x 3/4"
* 4	881120	1	BEARING
* 5	881630	1	SPACER
* 6	881157	1	BEARING, H.D. DRIVE
* 7	101045	1	SNAP RING
8	881066	1	1/2" COUPLING HALF

Hammonds Model 10T Injection System Manual

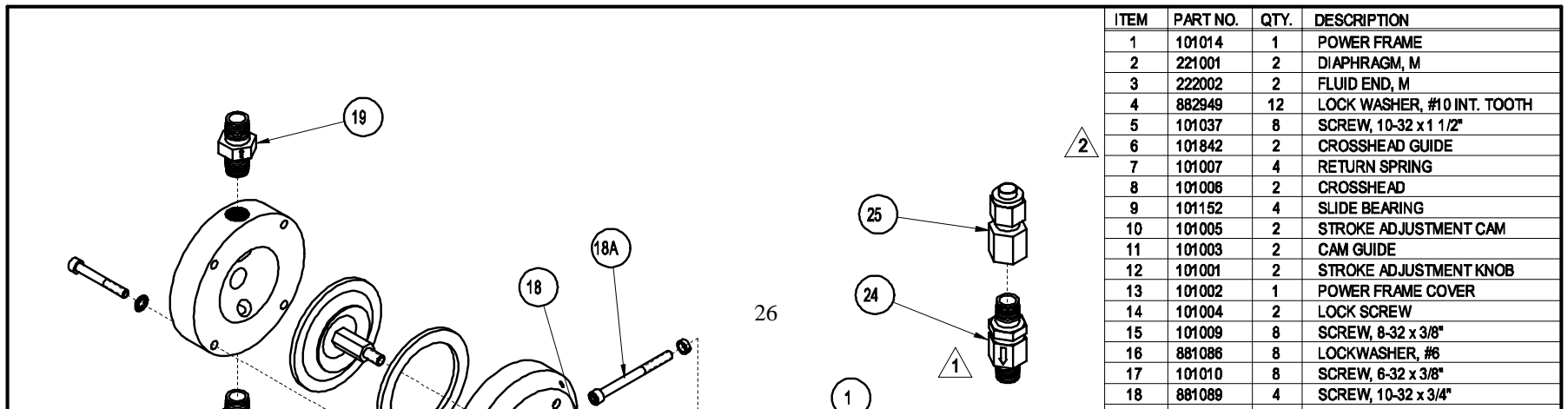

ITEM	PART NO.	QTY.	DESCRIPTION
1	101014	1	POWER FRAME
2	221001	2	DIAPHRAGM, M
3	222002	2	FLUID END, M
4	882949	12	LOCK WASHER, #10 INT. TOOTH
5	101037	8	SCREW, 10-32 x 1 1/2"
6	101842	2	CROSSHEAD GUIDE
7	101007	4	RETURN SPRING
8	101006	2	CROSSHEAD
9	101152	4	SLIDE BEARING
10	101005	2	STROKE ADJUSTMENT CAM
11	101003	2	CAM GUIDE
12	101001	2	STROKE ADJUSTMENT KNOB
13	101002	1	POWER FRAME COVER
14	101004	2	LOCK SCREW
15	101009	8	SCREW, 8-32 x 3/8"
16	881086	8	LOCKWASHER, #6
17	101010	8	SCREW, 6-32 x 3/8"
18	881089	4	SCREW, 10-32 x 3/4"

Hammonds Model 10T Injection System Manual

INSTALL CAP HAND-TIGHT...
DO NOT OVER-TIGHTEN!

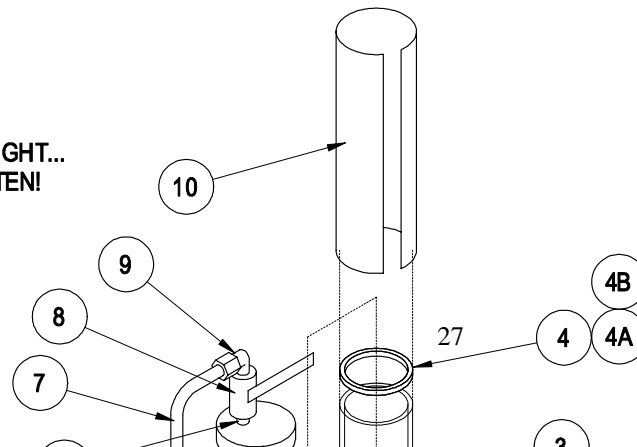

ITEM	PART NO.	QTY.	DESCRIPTION
1	152080	1	BODY, LARGE SIGHT FLOW
2	152025	1	FILTER ELEMENT
3	151014	1	GAUGE GLASS
4	151013	2	GASKET, VITON
5	152042	1	CAP
6	101069	1	NIPPLE, 1/4" X CLOSE
7	881139	1	TUBING, 3/8" X .035"
8	101230	1	ON/OFF VALVE, 1/4"
9	101068	1	ELBOW TUBE FITTING
10	881899	1	GUARD, GAUGE GLASS
4A	151010	2	GASKET, NEOPRENE, OPT.
4B	151025	2	GASKET, BUNA-N, OPT.

Hammonds Model 10T Injection System Manual

HAMMONDS SUCTION CALIBRATION GAUGE

CALIBRATION INSTRUCTIONS

- 1) IN ORDER TO CALIBRATE, THE PUMP MUST BE PRIMED AND PURGED OF ALL AIR. THE 3-WAY VALVE MUST BE SET TO INJECT.
- 2) WITH SUPPLY VALVE OPEN, SLOWLY OPEN VENT VALVE. THIS WILL FILL CALIBRATION GAUGE. FILL TO ZERO MARK. DO NOT OVERFILL. ONCE FULL, CLOSE VENT VALVE.
- 3) MAKE NOTE OF ADDITIVE LEVEL IN CALIBRATION GAUGE AND MAIN PRODUCT METER READING. BEGIN CALIBRATION BY FIRST CLOSING THE SUPPLY VALVE AND THEN OPENING THE VENT VALVE. START THE PRODUCT FLOW (SET FOR A SHORT TRIAL RUN).
- 4) AT THE END OF THE RUN, RECORD THE AMOUNT OF ADDITIVE THAT

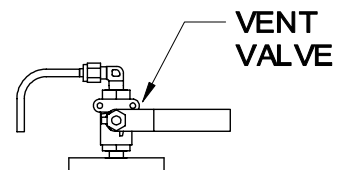

Hammonds Model 10T Injection System Manual