

**OPERATING INSTRUCTIONS  
AND  
MAINTENANCE MANUAL  
FOR**

**HAMMONDS MODEL 150-2S, RP1  
(8:1 RATIO)**

**FLUID POWERED  
ADDITIVE INJECTOR SYSTEM**

Manufactured by:



**HAMMONDS TECHNICAL SERVICES, INC.**

6807 West Little York Rd.  
Houston, Texas 77040

Phone: 281-999-2900

Fax: 713-896-9419

[www.hammondscos.com](http://www.hammondscos.com)

August 2025

# Hammonds Model 150-2S, RP1 (8:1 Ratio) Injector Manual

## TABLE OF CONTENTS

SPECIAL NOTICE TO USERS	3
INSTALLATION AND PREPARATION FOR STARTUP	3
INSTALLATION CONSIDERATIONS OF BARE UNITS	4-7
PREPARATION FOR CALIBRATION AND STARTUP	7-8
CALIBRATION AND STARTUP	8-11
NORMAL OPERATION	11
PROPER INJECTION RATIOS	11-12
TROUBLE SHOOTING THE SYSTEM	12-13
PREVENTIVE MAINTENANCE	13-14
PREVENTIVE MAINTENANCE SCHEDULE	14
DESICCANT DRYER INSTRUCTIONS	15
TYPICAL ADDITIVE RATIO CHART	16

### ATTACHMENTS:

- SYSTEM LAYOUT
- FLUID SCHEMATIC
- FLUID DRIVER
- INJECTOR PUMP
- DIAPHRAGM REPLACEMENT
- REMOTE PANEL INSTRUCTIONS (if equipped)
- SIGHT FLOW INDICATOR / CALIBRATION GAUGE
- SIPHON TUBE (if equipped)
- TANK ASSEMBLY (if equipped)

# Hammonds Model 150-2S, RP1 (8:1 Ratio) Injector Manual

## **SPECIAL NOTICE TO USERS** **PLEASE READ CAREFULLY** **BEFORE OPERATING EQUIPMENT**

This fluid powered additive injector system is designed to give consistent, dependable performance when operated and maintained according to manufacturer's recommendations. However, being a mechanical device, it is subject to failure from improper installation, wear, human error and operating environments beyond the control of the system. Because of this fact, it is the responsibility of the operator to make certain that:

- A. The system is installed properly.
- B. The system is being operated properly.
- C. The system is actually running during product transfer.
- D. The system is checked after the transfer operation to make certain the proper amount of additive was injected during the operation.

The performing of these checks by the operator eliminates the possibility of product not having the proper customer required additive ratio. Therefore, since the manufacturer cannot be present during each transfer operation, the responsibility for checking the performance of the system is that of the operator. Should there be any questions whatsoever, the operator should consult the distributor from whom the unit was purchased.

**DO NOT TAKE CHANCES.....DO NOT GUESS.....BE ABSOLUTELY CERTAIN THAT THE SYSTEM IS INSTALLED AND WORKING AS IT SHOULD.**

The user/ operator carries the final responsibility to make certain the system is operating properly.

## **INSTALLATION AND PREPARATION FOR STARTUP**

In most cases, the Hammonds fluid powered injector is shipped complete and ready to operate. The system should include appropriate fittings to suit your specific application. Flow direction is marked on the fluid motor housing, additive pumps and check valves. Any and all flow restricting devices such as ON/OFF ball valves, remote panels, sight flow indicators or suction strainers must be installed on the suction side of additive pumps.

### **CAUTION**

**Do Not Attempt To Use This Device Without Understanding And Following Proper Safety Precautions Regarding System Grounding, Fire Safety And Special Handling For Potentially Dangerous Additives.**

Consult your Engineering Department for their specific instructions. Make certain all personnel involved with this system are thoroughly familiar with safe operating practices.

If your system has been purchased "bare," consult your equipment distributor for help in selecting hoses, fittings and other related accessories. Selection of materials compatibility, location of unit within the system, effect of the unit on the system and injection point of the additive are also factors that should be discussed by factory authorized personnel.

# Hammonds Model 150-2S, RP1 (8:1 Ratio) Injector Manual

If no factory-authorized distributor is available, consult the factory directly for assistance.

**HAMMONDS TECHNICAL  
SERVICES, INC.  
6807 West Little York Rd.  
Houston TX 77040  
Phone: (281) 999-2900  
Fax: (713) 896-9419**

## **INSTALLATION** **CONSIDERATIONS OF BARE** **UNITS**

Hammonds additive injector systems may be installed in a wide variety of applications, systems, and operating conditions. **This Manual Makes The Assumption That The Purchaser Has Consulted With A Factory Authorized Distributor Or The Factory And Has Approval For The Application And Installation.** If this is not the case, listed below are a few considerations that should be reviewed before installing a unit in an existing system.

### **FLOW CONSIDERATIONS**

The Hammonds Model 150 requires a minimum of 7 and up to 75 GPM to deliver consistent ratios. This does not mean that the system cannot be used in cases where startup and shutdown fall under the 7 GPM minimum. However, these installations require calibration to compensate for the lower flow rates during these periods of operation. Check with the factory if you have any questions in the area of performance.

### **MATERIALS OF CONSTRUCTION**

The standard material in a Hammonds Model 150 fluid driver is anodized cast aluminum housing. Optional material is carbon steel.

### **INJECTION POINT OF ADDITIVE**

Some additives may adversely affect other components in the product handling systems, for example seals in meters, valve seals, aluminum and filter elements to name a few. The Hammonds injector systems do an excellent job of mixing the additive in the fuel systems, while injecting at an almost continuous rate. Because of this superior mixing and very small concentration of additive in any one point, many customers feel that this is not a problem. **SOME DO**, and therefore, should use their own judgment as to the effect of these additives. **Hammonds Technical Services, Inc. Can Only Advise You Of The Possible Hazards.** It is up to the owner of the equipment to decide his preference as to location of the additive injection point. It can be placed at any point in the system. The 150 comes with the injection point directly ahead of the fluid motor for good blending. It can be located elsewhere very easily. If the injection point is moved from the body of the injector, the 1/4" tapped hole must be plugged, the inlet check valve moved to the new location, and the injection tubing rerouted to the new location. An injection check valve must always be used regardless of location.

# Hammonds Model 150-2S, RP1 (8:1 Ratio) Injector Manual

## WHERE TO PHYSICALLY MOUNT THE INJECTOR ON A REFUELER

If the unit is to be installed upstream of the filter separator (monitor), it can be placed at any place that is convenient between the system pump and the filter separator. If installation is to be downstream of the filter separator, the most ideal location is just after the filter separator, ahead of the de-fueling valve or pressure control valve. The unit can be installed between the de-fueling valve and the hose reels. However, this will cause some loss of efficiency in the de-fueling capability, since the system pump will be pulling through the injector motor. It does not harm the unit to run backwards. If the system is installed after the pressure control valve, overall flow may be effected since the control valve monitors system pressure and compensates accordingly. The nominal backpressure produced by the injector could have an effect on the operation of the pressure control valve and its reaction to changing system conditions, you may effect flow volumes. If you are in doubt about this particular subject, and feel that your chosen mounting location will effect the valve, consult the factory. Most systems can be adjusted to compensate for this minor loss.

Model 150 can be mounted in most any convenient location. The standard product connection is 1-1/2" 150# RF flanges. The performance of the 150 is not affected by changes in pipe direction or other components such as valves, strainers or meters directly before or after the injector. However, care should be taken in placing the unit too close to other items such as turbine meters that may be sensitive. Consult other manufacturers for

advice in placing the fluid motor adjacent to their specific equipment.

## MOUNTING ATTITUDE

The Model 150 can be mounted in a horizontal, vertical, or even a slanted pipe with one condition. The main motor shaft that powers the injector **MUST always** be horizontal. If this is not done, premature wear will occur in the unit, causing close design tolerances in the unit to become excessive. This will lead to a loss in the system's ability to operate correctly at low flow rates. **Study The Installation Drawing At The End Of The Manual Carefully. Consult Your Local Distributor Or The Factory If You Have Any Questions Whatsoever.**

## LOCATION RELATIVE TO METERS

Hammonds injectors can be installed at any point in the system. If the unit is placed upstream of the meter, it will precisely inject additive to the system, whether a single hose or dual hoses are used.

## SPACE REQUIREMENTS

The system is designed with easy service in mind. The entire rotor and pump assembly can be removed, where possible, from the housing without disturbing the system piping. Ample room should be reserved in the installation for this removal. The injector pump is removed from the side on which it is mounted. Approximately 2" should be allowed for complete removal of the pump. Should the fluid motor need service, a clearance of 9" is required on the pump side to remove the rotor and side plate. Also, allow room for the

# Hammonds Model 150-2S, RP1 (8:1 Ratio) Injector Manual

operator to have visual access to the pump controls for calibration adjustment purposes.

## ON/OFF OPERATION

There are two methods for providing ON/OFF operation to the system. The first uses a remote panel that includes a special rotary valve connecting the additive tank and injector appropriately, and the other is a simple ball valve placed in the additive supply line that connects the additive storage tank and the injector. Although the valve can be located at any point, it works best located as close to the injector suction as possible. The valve should be a simple two-way, 1/4" stainless steel ball valve. Make certain that the "trim" or seal in the valve is Teflon®, or an elastomer that is compatible with the additive to be used.

If the injector is equipped with a diaphragm type pump, it can be operated "DRY" without damage. When the additive supply valve is turned OFF, the injector simply maintains a suction on the additive line until the valve is opened for operation. The injector immediately begins pumping when the valve is returned to the ON position. A diaphragm type injector pump can operate indefinitely in the OFF position, but if this is going to be normal practice or if this is a plunger type pump, simply mark the stroke setting on the dial and stroke the pump to zero and lock it down. This will extend the life of all the moving parts. When injection is needed, set the dial to the marked position.

When a Hammonds remote operating panel is used, the OFF position allows the injector pump to

recirculate the additive back to the additive storage tank.

## **CAUTION**

**NEVER, NEVER** turn the injector off by placing an ON/OFF control valve on the discharge side of the pump. This blocks the discharge of the pump, causing damage to the diaphragms and pump parts. If the system is equipped with a relief valve, the diaphragm or plunger seal could rupture after blocking the discharge. This would result in an uncontrolled leak of additive, as well as preventing the system from operating.

## LOCATION OF THE ADDITIVE

The additive tank should always be placed as close to the injector as possible. Ideally, the tank should be at the same level, or slightly higher than the unit providing a flooded suction to the injector. If this is not possible, the injector, depending upon the application and the model of pump, will pull a suction lift. **NOT ALL PUMPS WILL.** The end user is responsible to make sure there are absolutely no leaks in the suction line of the injector. A pinhole will prevent the system from priming and/or operating efficiently. Tape all threaded connections carefully with Teflon® sealant.

## ADDITIVE PAILS AND SIPHON TUBES

The popular use of an additive pail equipped with a siphon tube is a convenient way to store additive without the expense of a custom made tank. But, when the pail is used out-of-doors, in the weather, certain precautions must be considered. The top of the pail must

# Hammonds Model 150-2S, RP1 (8:1 Ratio) Injector Manual

be sheltered from the rain and snow. If rain or snow is allowed to accumulate on the top of the pail, some of the water will make its way into the pail, thereby contaminating the additive. The water that leaks in will go to the bottom of the pail as it is heavier than most fuel additives. The inlet of the siphon tube is close to the bottom of the pail and will pick up this water injecting it causing problems.

Caution must be used when changing a pail of additive. Before removing the siphon tube, dry the area of the pail around the adapter which threads the siphon tube into the pail. Disconnect the supply line to the pump. Be careful to keep the ends of the line clean and dry. Now unthread the siphon tube assembly from the pail. Examine the tube for any contaminants and the threads for any dirt or water. Make certain that the top of the new additive pail is clean and dry. Install the siphon tube assembly and reconnect the supply line. Examine the condition of the desiccant dryer tube attached. Replace the desiccant dryer with a new one when it is  $\frac{3}{4}$  pink. This will insure your additive supply is clean and dry. Reinstall the pail in its sheltered, dry location.

## **TUBING AND CONNECTIONS**

High-density Synflex® tubing is provided with every system for refueler installation. Although stainless steel tubing would be more desirable, the poly tubing is easier to install and less expensive. Make sure all tubing is carefully secured and grouped together, whenever possible. **USE CAUTION TO NOT CRUSH OR KINK TUBING WHEN INSTALLING.** Tubing runs should be as

straight and level as possible with a minimum of low spots or “traps” that can trap air during startup. Tubing should not be allowed to “thump” or vibrate during operation, as this will cause premature fatigue and failure.

## **INSTALLING THE REMOTE PANEL**

The remote operating panel, RP1-1, uses a rotary valve that connects injector suction, discharge, additive tank and injection point at the proper time for the system functions of “INJECT”, “OFF”, “BLEED”, and “CALIBRATE”. When installing a remote panel, make certain connecting lines are level, well secured and as short as possible. Improperly connected lines will generate very confusing operating conditions that are difficult to diagnose. **FOLLOW THE INSTRUCTIONS WITH THE UNIT CAREFULLY.**

## **PREPARATION FOR CALIBRATION AND STARTUP**

**Before Attempting To Start The System Or Make Calibrations, Please Read The Following Information Carefully.**

During startup and calibration, you will be bleeding the system of air, collecting samples of additive during the calibration and checking for possible leaks throughout the system. Provisions should be made for collection or clean up of spilled fluid. Attempts should be made to minimize losses during these procedures. If the additive being handled is flammable, fire safety precautions should be taken. (Since the installation may also be tested at this time, extreme caution should be used in checking for

# Hammonds Model 150-2S, RP1 (8:1 Ratio) Injector Manual

leaks of the main line.) If you wish to set the system up for leak-free testing and calibration with zero spillage, please consult your local distributor or the factory for help in doing so. Hammonds is glad to suggest any necessary parts and procedure for "zero spill" startup and calibration.

## A WORD ABOUT ADDITIVES

Most additives being used in fuels today have at least some degree of toxicity. Many are very dangerous. Extreme caution should be taken in handling additives. Remember, the additive is placed under pressure when being injected into the line, and when collecting samples during calibration, some spillage may occur. Be careful; wear protective clothing including eye protection. Be sure you have facilities to wash off any additive that may come in contact with your skin. Read all additive manufacturers safety precautions and Material Safety Data Sheets, following them to the letter.

### HERE IS WHAT IS NEEDED:

- Appropriate safety protection equipment.
- Eye protection in the form of safety goggles.
- An assortment of wrenches that fit the various fittings on the system. Note: two (2) 10" crescent wrenches will normally take care of any adjustments to fittings you may have to make. One to hold the fitting, and one to hold the adjacent fitting.
- A marked graduated glass bottle that is marked in either cc's or ounces. (At least 16 oz.)

- A stop watch.
- A means of determining the flow rate of the main system.
- A small pocket calculator is helpful.
- A clipboard is helpful with pad of paper.
- AT LEAST ONE, AND PREFERABLY TWO HELPERS
- A large container or catch basin to collect the output of the pump while you are not actually calibrating the system.

**REMEMBER:** Any plumbing system varies with temperature and fluid being pumped. The system also changes as parts of the pump wear.

## CALIBRATION AND STARTUP

**IF YOUR INJECTOR SYSTEM IS EQUIPED WITH A CALIBRATION GAUGE OR REMOTE PANEL, FOLLOW THE INSTRUCTIONS FOR THEIR USE IN THE BACK OF THIS MANUAL.**

**Please Follow These Steps In Their Given Order. Read Them Over Carefully Before Starting, Then Follow Them To The Letter. If There is Any Part Of The Procedure That Is Not Clear, Consult Your Local Distributor Or The Factory Directly.**

1. Make certain the additive tank is full of the proper additive.
2. Open the suction valve between the tank and the pump. This valve should be located at any point between the additive tank and the injector.

## Hammonds Model 150-2S, RP1 (8:1 Ratio) Injector Manual

3. All systems are calibrated at the factory to customer specified requirements. So if adjustments are required, they should only be minor. If this is the case, go directly to step 7.

4. If you are starting from scratch in the calibration and adjustment, loosen the stroke adjustment locking screws located on the bottom of the pump body. This will allow the stroke adjustment to be moved.

5. Adjust the stroke adjustment knob located on the pump body to approximately 50%.  
**CAUTION:** Do not turn this adjustment knob with excessive force. If this is difficult to adjust, simply rotate the main rotor shaft, by producing flow in main product line.

6. Lock the stroke adjustment locking screw down firmly.

### **THE FOLLOWING STEP (#7) IS FOR A SYSTEM NOT EQUIPPED WITH A REMOTE PANEL**

7. Set the 3-way valve in the "calibrate/bleed position." This is done by making certain that the handle on the valve is positioned so that additive will exit through the short tube. A check valve sized for the application should be installed on the end of this tube. If no check valve is there, contact your distributor or the factory.

8. Make certain all product connections going to and from the system are in their proper, locked position to ensure safe, leakproof flow

of product through the fluid motor. Double check the flow direction arrows located on the fluid motor housing, and check valves above and below the pump head to ensure that the system is installed properly.

9. At this point, consider the information you will have to gather during the next few steps of the calibration process.

A. What will the product flow rate through the unit be?

B. What is the length of time that the calibration will cover?

C. What is the amount of additive in ounces or cc's that you will need to collect based on the duration of the calibration?

### **You Should Have the Answer To All Of These Questions Before Your First Trial Run.**

10. Before starting the main product flow through the system, make certain everyone understands that you will run the system for, let's say, one (1) minute or one hundred (100) gallons. Even shorter runs are fine, especially if you are running at high flow rates.

11. Place the measured graduate under the calibration tube. (The short tube with the check valve on the end.) Put on your eye protection.

12. At the command of the timekeeper, or the person watching the flow meter, start the main product pump.

## Hammonds Model 150-2S, RP1 (8:1 Ratio) Injector Manual

13. Give the system a few seconds to gather momentum and flow through the fluid motor. Confirmation that the fluid motor is running may be obtained by removing the stroke adjustment knob(s) and locking screw(s) so that the graduated power frame cover may be removed. This will expose the pump drive bearing mounted on the end of the shaft. If the fluid motor is operating properly, this bearing will be turning around in an eccentric motion.

14. If the pump is being started up for the first time, it will take a few seconds to prime itself and begin discharging fluid from the calibration tube. Is your eye protection on? If not, PUT IT ON NOW!

15. As soon as the pump begins discharging a clear, air free stream of fluid from the calibration tube, you are ready to begin your calibration. At this point, the system is primed.

16. You will now prepare to make your first actual calibration run. Empty your collected additive back into the tank, putting the bottle back under the calibration tube. **IF YOUR SYSTEM IS EQUIPPED WITH A REMOTE PANEL, SCREW THE CALIBRATION BOTTLE INTO THE RECEPTACLE ON THE PANEL.** Notice the setting on the main product meter, set your stop watch at zero.

17. When ready, start the system again. Stop it at the decided time interval or meter reading. Calculate the amount of product that

traveled through the system. Measure the amount of additive gathered, and record the amount of elapsed time.

18. It will be at this time that you will have to calculate how much additive you should have collected for the amount of fuel that the system pumped. This, of course, depends upon the ratio that is required. The following example is the easiest way of explaining the procedure without getting too complicated. It is not the only way...use it if you like.

Example condition:

Amount of product pumped: 500 gallons  
Ratio of additive desired: 250 PPM  
(Parts per million)

It is assumed that the operator will know how much product is being pumped through the system in a given length of time. If, for example, you have a meter that registers the flow in gallons, you simply record the gallons at the beginning of the timed run, and then again at the end of the run. If you run for one (1) minute, you simply subtract the beginning number on the meter from the number registered after the run. This will give you the gallons per minute (GPM). Having to make this calculation is the only reason for timing the run. You can accomplish the same result by just watching the meter and stopping the system when you have totaled the desired amount of gallons through the system. In any case, you must know the amount of product passing through the system before calibration can begin.

# Hammonds Model 150-2S, RP1 (8:1 Ratio) Injector Manual

First, change the gallons pumped into ounces by multiplying total gallons (in our example 500) by 128 (128 oz. to a gallon). The answer is 64,000 ounces.

Second, divide by 1,000,000. The answer is .064. Since you are dealing in 1/1,000,000 (one part per million) of the total for your ratio, you must find out what 1/1,000,000 of the 500 gallons is, .064 ounces is 1/1,000,000th (one part per million) of 500 gallons of fuel pumped.

Third, multiply the .064 x 250 (for 250 PPM ratio). The answer is 16 ounces.

So, you should collect 16 ounces of additive for every 500 gallons of fuel pumped.

These are all large, round numbers. You may, for example, only be running at 50 GPM, not 500. Use the same procedure; just change the numbers to fit your application.

No two systems will ever perform exactly the same. For this reason, the procedures given for calibration are general in nature. Obviously, it is impossible to provide a graph or table that would be absolutely accurate in every case. With that in mind, all tables and graphs should be used as general guidelines. Remember, the calculated, timed and measured output that you gather is absolute. Trust your figures and your calculations.

## **NORMAL OPERATION**

Following initial start up and calibration, the system requires very little attention other than making certain

that additive tank levels are maintained. Operators will quickly become accustomed to the performance of the system by observing the Suction Sight Flow Indicator. On-spec injection will cause a certain response in the indicator, and with some practice, operators will be able to observe the system and qualify performance at a glance. *This does not mean that system calibration should not be periodically checked!* However, during a busy workload, these visual checks will provide assurance to the operator that the system is functioning.

Assuming the system remains set up and operating at least intermittently, calibration is required perhaps every 1 – 3 months. Good record keeping of additive inventory and use levels compared to fuel handled can give a good indication that additive ratio is on specification. Test such as the refractometer for FSII content should be the final test to verify additive injection ratios.

See the section on preventative maintenance for suggestions as to regular maintenance.

## **PROPER INJECTION RATIOS**

Your system should be equipped with some sort of calibration device, i.e.; suction calibration gauge, additive meter, Hammonds remote panel with pressure check valve, or a simple pressure check valve on the end of the bleed tube. If it is not equipped with any of these devices, calibration of your system will be done using only atmospheric pressure. Volumetric calibration at atmospheric pressure is not recommended. It will not

# Hammonds Model 150-2S, RP1 (8:1 Ratio) Injector Manual

necessarily bring you within an acceptable range of additive injection. The only true evaluation for proper ratio is the ASTM D-5006 evaluation for fuel system ice inhibitor (FSII). Do not depend on volumetric calibration to ensure on-spec performance because line pressures can vary and additive injector parts wear over time. Contact Hammonds Fuel Additives, Inc. for supply of quality fuel system ice inhibitor and fuel testing procedures.

## **TROUBLESHOOTING THE SYSTEM**

The following conditions are given as a means of troubleshooting the system. Each condition lists a number of possible causes. In most cases, trouble can be solved by the use of this section. Please read it carefully before attempting repairs or making any changes in the system.

### **FLUID MOTOR IS NOT TURNING**

A. Insufficient flow to turn the motor. A minimum flow of about 7 GPM needed to start the system.

B. A rag or some other object is jammed in the line preventing the fluid motor from turning.

C. A diverter valve is blocked downstream of the system, blocking the fuel flow through the system.

D. On a truck or hydrant system, a de-fueling valve is left open starving the fluid motor for product flow.

E. If the unit has been recently serviced internally, the rotor might be installed backwards. Consult the factory before disassembly.

F. The fluid motor may be installed in the wrong direction of flow.

### **FLUID MOTOR IS TURNING AND PUMP RUNS, BUT WITH NO OUTPUT**

A. Pump is air-locked. In some cases where there is a very long line running from the injector head and the point of injection into the system, there is sufficient air volume to cause the pump to act as a compressor. It is not able to open the valves throughout the system and therefore, cannot pull a suction of fluid to the pump. Loosen the connection at the injection point check valve and allow it to remain open until the pump begins pumping.

B. One or more of the suction or discharge check valves are not working. While the pump is running, tap on the side of the valves, one at a time. This will generally jar them loose. The poppets and seals are very small, and will sometimes become stuck. After the valve is loosened and has a supply of fluid, usually it will not stick again.

C. The pump is not getting additive. Check that the valve between the pump and the tank is open. Check all the connections in the line between the pump and the tank.

D. The vent on the tank is not open causing the pump to pull a vacuum. Open the vent. Check to see if the cap has been removed from the dryer cartridge, if so equipped.

E. The pump stroke is set at zero.

F. The additive tank is empty...don't laugh, it happens.

### **INJECTOR IS OPERATING BUT WITH REDUCED OUTPUT**

A. Leaking suction line or trash in one of the pump check valves.

B. Air leak in suction side of system. Note: leaks may be anywhere upstream

# Hammonds Model 150-2S, RP1 (8:1 Ratio) Injector Manual

of the additive pump, through the remote panel back to the additive container.

C. Defective tubing that has tiny holes or deterioration from ultra violet light.

D. Leaks in threaded connections - suction side.

E. Injector diaphragm may be pulled out in back, causing injector to pump in forward portion of stroke only. This will not create a visible leak, but will reduce output by 50%. It usually happens after many hours of operation.

F. If equipped with a plunger pump, the plunger seal (o-ring) may be worn and needs replacing. Also, check plunger for signs of wear, replace if necessary.

G. Performance of the system is slipping. Fluid motor vanes are badly worn. This would only be probable after a very high number of hours of operation.

## **PREVENTIVE MAINTENANCE**

1. Make certain to use only clean, fresh additive that has been stored in a sealed container. Most additives are moisture sensitive. Some will form heavy crystals if allowed to accumulate moisture. These crystals will stop the pump in very short order, or cause calibration to be changed due to clogging of the valves and other parts.

2. Check the additive suction strainer or filter screen in the sight flow indicator, if so equipped, at least every six months. More often if there is an indication of possible contamination.

3. Check the system for leaks at every use. This is an extremely important safety procedure, since some additives are flammable, caustic and corrosive.

4. Check for leaks from the seal that is located at the exit point of the injector

output shaft in the side plate housing. This should be done at each operation. Leakage at this point usually indicates that the mechanical seal inside the fluid motor housing is leaking. A leak here will be jet fuel, and is not only dangerous from a fire standpoint, but will quickly ruin the bearings on the rotor shaft, since all lubricant will be washed away.

5. Check the fittings for leakage around the suction strainer or sight flow indicator, if one is used on the pump. Check this fitting each time the filter is changed or cleaned. Make certain there are no leaks in the suction line. A very small leak will either change the operation of the pump or prevent it from operating altogether.

6. Visually check around the pump head and make certain there is no leaking of additive around the fluid end. If there is, check the tightness of the head bolts. (40 inch pounds each)

7. Check the grease around the eccentric drive bearing in the pump every 6 months. Use a good quality white lithium spray lubricant.

8. It is recommended that the injector diaphragm or plunger o-ring be changed at least every 12 months. Every 6 months under extreme operating conditions. Doing so will prevent unexpected failures and unscheduled downtime.

Hammonds injectors are very dependable. If installed properly and sized appropriately to the application, they require very little maintenance. With the exception of the grease on the eccentric bearing mentioned in STEP 7, there is very little actual maintenance to do. Remember; keep the additive and the suction filter clean. If you have problems with the pump working, it is

## Hammonds Model 150-2S, RP1 (8:1 Ratio) Injector Manual

usually in the suction side of the system (between the additive tank and the injection pump). Suction lines and fittings are notorious for leaking just enough to prevent the system from working. Always check to ensure optimum suction conditions, should problems occur.

Remember, a leak in the suction allows air from the outside to be introduced into the system. It does not always mean a visible leak of additive. If the pump loses its prime or output is erratic, chances are good that there are problems in the suction side. Otherwise, if it is working...leave it alone!

### PREVENTATIVE MAINTENANCE SCHEDULE

**NOTE:** It is important to read the previous pages on preventative maintenance. These intervals are general, and may vary according to individual applications and severity of service.

SERVICE FUNCTION	0-4 HRS DAILY	5-8 HRS DAILY	8+HRS DAILY
Check additive filter screen	Monthly	Monthly	Monthly
Check system for additive/fuel leaks	Daily	Daily	Daily
Inspect diaphragms/plunger seals	12 Months	6 Months	3 Months
Replace diaphragms/plunger seals	12 Months	As needed	As needed
Check eccentric bearing grease	6 Months	3 Months	Monthly
Check stroke adjustment parts for looseness	Monthly	Monthly	Monthly
Replace stroke adjustment parts	24 Months	As needed	As needed
Disassemble and inspect fluid motor housing and internal parts	24 Months	12 Months	8 Months

# Hammonds Model 150-2S, RP1 (8:1 Ratio) Injector Manual

## DESICCANT DRYER

Your Hammonds additive system may include either a custom additive tank or one of several Sight Flow Indicators. Both custom tanks and the 5-SF and 55-SF Sight Flow Indicator come equipped with a desiccant dryer cartridge. These units come in several different sizes.

Most systems come equipped with the standard 3/4" cartridge. This unit is attached to the tank or Sight Flow Indicator via a short length of black rubber hose. The cartridge has a housing constructed of a clear poly material and is filled with a blue colored desiccant crystal. All these units are shipped from the factory with a rubber cap on the unattached end of the cartridge.

Some systems may come equipped with a large canister measuring approximately 2" diameter and 10" in length. These units perform the same function, just on a larger scale. Due to their greater capacity, they last longer between service. These units are sealed from the factory by a small, plastic plug or rubber cap, which is located either on the bottom or one side of the canister.

The purpose of all desiccant dryers is simply to remove moisture from the air as the system breathes. All tanks or portable sources of additive supply must be vented to atmosphere in order for the injector to operate. If moisture in this venting air is not removed, some additives are either ruined or seriously damaged. Fuel System Icing Inhibitor (FSII), for example, is designed to seek out water in a fluid. So, when enough moisture is absorbed into the container, the FSII is diluted, and at some point, will be

ruined. Biobor® JF, an anti-fungal material, will form crystals in the presence of moisture and not only perform unsatisfactorily as an additive, but will stop up pumps and lines as well.

The following instructions apply to all desiccant cartridges:

A. Remove the rubber cap or plug when the system is placed into service.

B. Observe the color of the desiccant. The original color is blue. As moisture is absorbed, the color will change to pink. When the cartridge is 3/4 pink, it should either have its contents removed, dried and replaced, or the entire unit replaced.

**NOTE:** The contents can be removed from plastic container, placed on a pan and baked at 400°F in a conventional oven until the moisture has been removed. When the color blue returns, the cooled material may be reinstalled into the cartridge and is again ready for service.

Color change and cartridge life is totally dependent on humidity. The more moist the air, the shorter the life. Keeping it dry is especially important if additive is not consumed rapidly. Check daily and service as needed.

## Hammonds Model 150-2S, RP1 (8:1 Ratio) Injector Manual

### TYPICAL ADDITIVE RATIO CHART

<u>GALLONS</u>	<u>135 PPM*</u>	<u>270 PPM*</u>	<u>1250 PPM*</u>
100	1.7	3.4	16.0
200	3.4	6.9	32.0
400	6.9	13.8	64.0
500	8.6	17.2	80.0
700	12.0	24.0	112.0
1000	17.2	34.5	160.0

\*PPM amounts shown are in ounces

# Hammonds Model 150-2S, RP1 (8:1 Ratio) Injector Manual

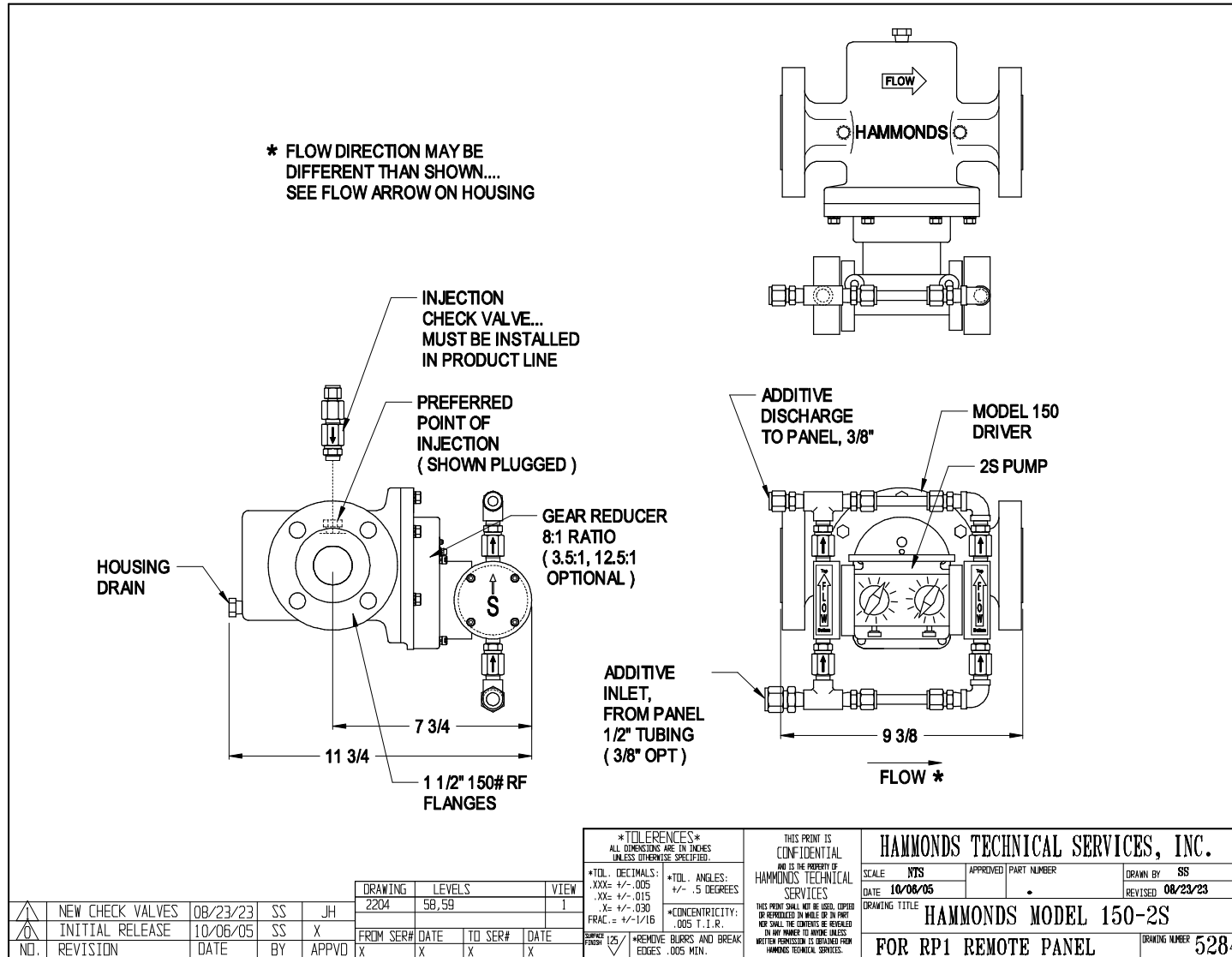

# Hammonds Model 150-2S, RP1 (8:1 Ratio) Injector Manual

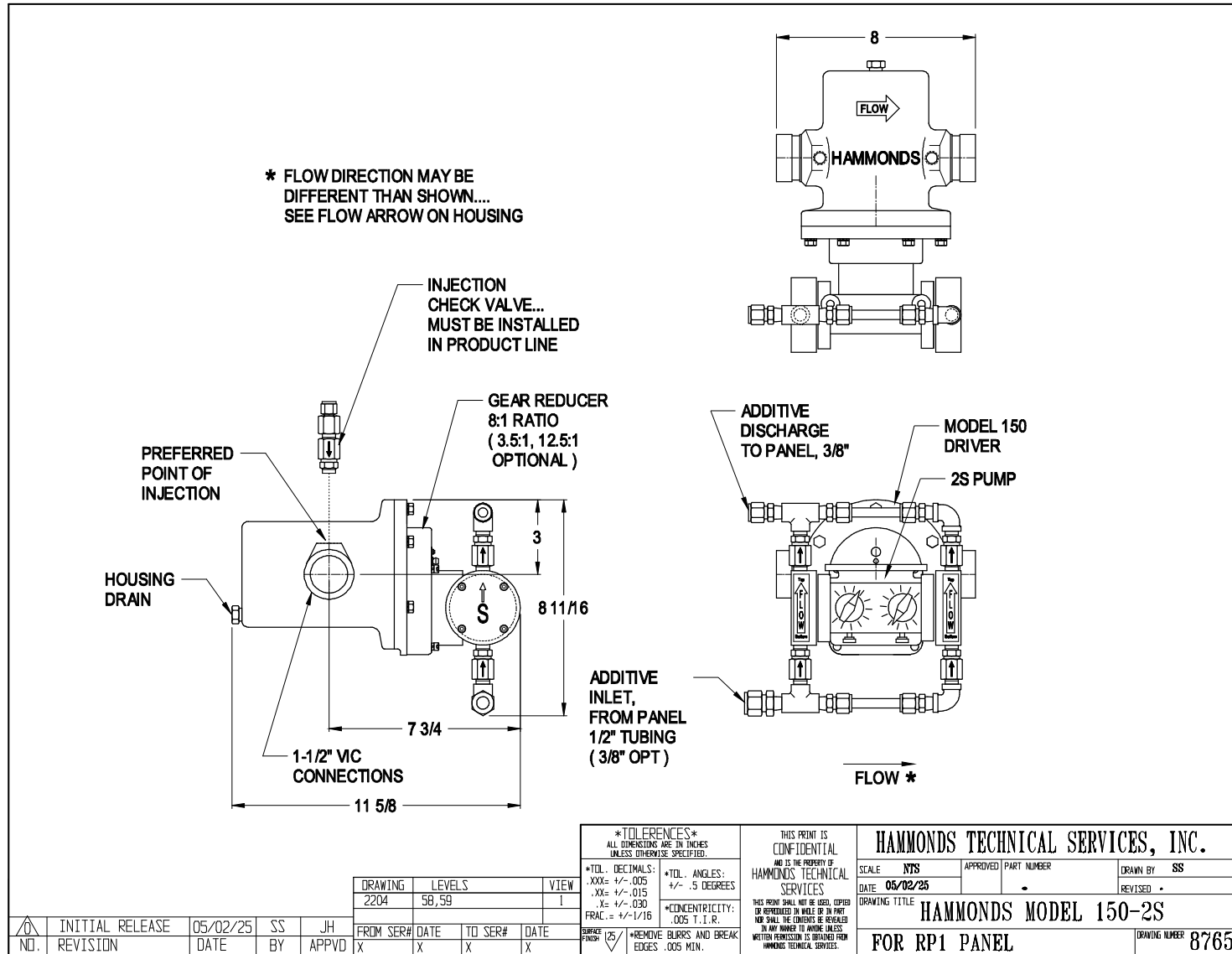

# Hammonds Model 150-2S, RP1 (8:1 Ratio) Injector Manual

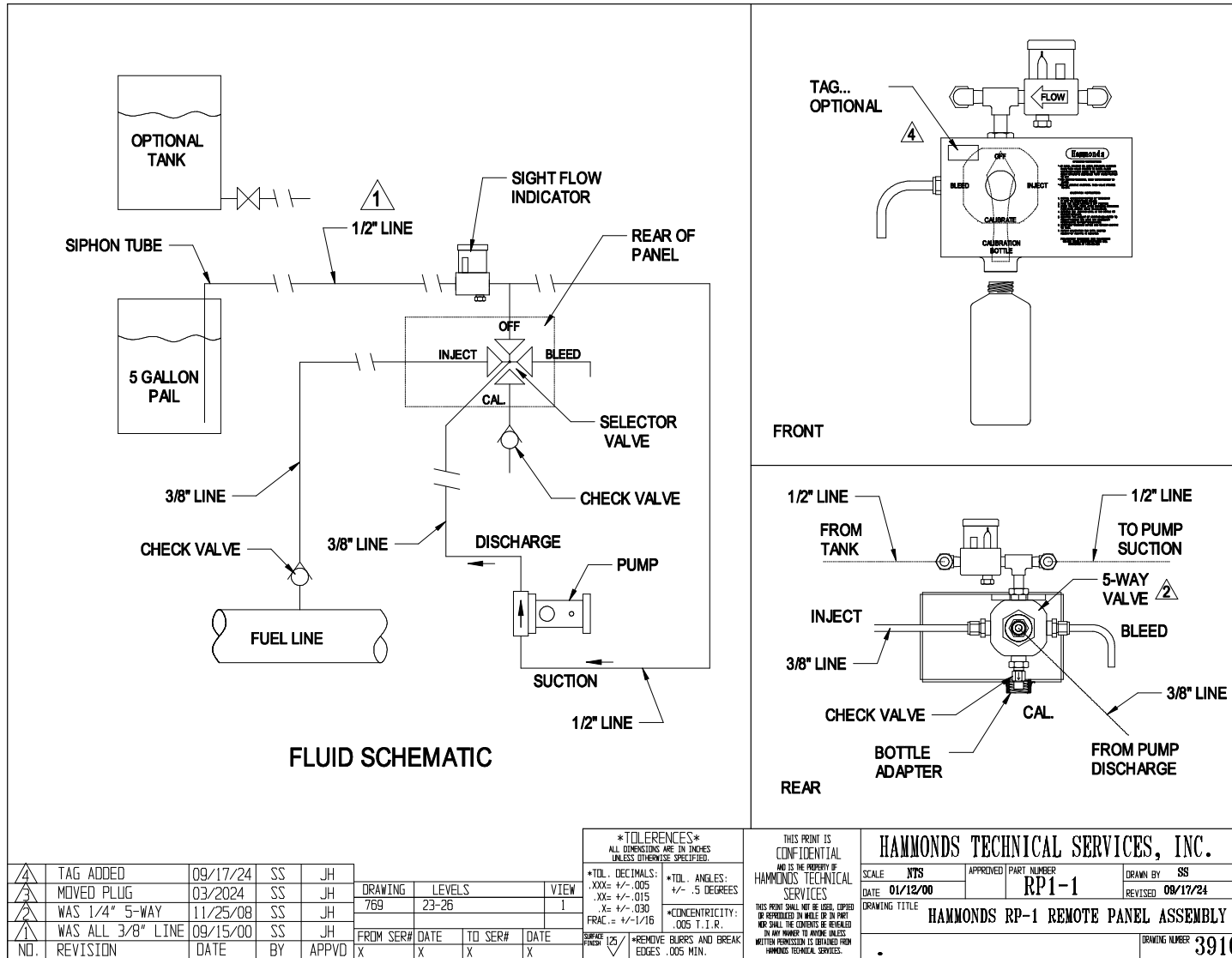

# Hammonds Model 150-2S, RP1 (8:1 Ratio) Injector Manual

ITEM	PART NO.	QTY.	DESCRIPTION
1	151005	2	HEX PLUG, 1/4" NPT
2	150012	2	WEAR RING
3	150229-1	1	SHAFT
4	150086	1	ROTOR
5	150231	1	HOUSING, 1 1/2" 150# RF FLANGED
6	150232	1	HOUSING, 1 1/2" VCTAULIC
7	150287A	1	HOUSING, 2" 150# RF FLANGED
8	150229-01	1	KEY, 1/8" SQ. x 1"
9	881009-150	1	MECH. SEAL, VITON (STD.)
10	141050-150	1	MECH. SEAL, BUNA-N (OPT)
11	150230	1	COMBO END PLATE
12	881259	6	LOCK WASHER, 1/4, SS
13	883343	6	HEX BOLT, 1/4-20 x 1-1/4, SS
14	150288	2	ROLL PIN, 1/16 x 7/16
15	881080	3	SNAP RING
16	150070-1	1	18T PINION (8:1)
17	881522	1	GREASE VENT
18	881521	1	GREASE FITTING
19	150072	1	GEAR CASE
20	101045	1	SNAP RING
21	150011	1	OUTPUT SHAFT
22	881157	1	H.D. DRIVE BEARING
23	881630	1	SPACER
24	881120	2	BEARING
25	881024	1	OIL SEAL
26	881119	2	SNAP RING
27	881545	4	SCREW, 10-32X1 1/4
28	101038	4	LOCK WASHER, #0 HC
29	150-144T	1	144T GEAR ASSY (8:1) W/ #27, 29
30	150075	1	COLLAR
31	103416	1	O-RING, VITON (STD.)
32	103395	1	O-RING, BUNA-N (OPT)
33	255051	2	SCREW, FH-6-32X1/2
34	881063	2	BEARING
35	150127	6	VANE, TEFLON
36	885125	1	SPACER (OPTIONAL) / S
37	883025	1	SET SCREW, 1/4-20 x 1/4"
OPTIONAL RATIO:			
38	150073-1	1	12T PINION (12.5:1)
39	150-150T	1	150T GEAR ASSY (12.5:1) W/ #27, 29

△ WAS PLT'D HARDWARE	08/23/23	SS	JH
△ WAS 150073	05/17/22	SS	JH
△ WAS 1/8" ROLL PIN	09/14/15	SS	JH
△ ADDED PART NO.	02/03/15	SS	X
△ ADDED OPTIONAL	01/29/15	SS	X
△ ADDED 2" RF PN	01/15/14	SS	X
△ NEW SEAL PN	11/11/13	SS	X
△ ADDED SHIM SPACER	09/11/13	SS	X
△ NEW ASSY. NO.	04/12/12	SS	X
△ INITIAL RELEASE	07/21/04	SS	X
NO. REVISION	DATE	BY	APPVD

DRAWING		LEVELS		VIEW
1544	6, 25-28			I
FROM SER#	DATE	TO SER#	DATE	
X	X	X	X	

**\*TOLERANCES\***  
ALL DIMENSIONS ARE IN INCHES UNLESS OTHERWISE SPECIFIED.

\*TOL. DECIMALS:  
XX± ±.005  
XX± ±.015  
.X± ±.030  
FRAC. ± ±.1/16

\*TOL. ANGLES:  
±.5 DEGREES  
\*CONCENTRICITY:  
.005 I.I.R.

\*REMOVE BURRS AND BREAK EDGES .005 MIN.

THIS PRINT IS CONFIDENTIAL AND IS THE PROPERTY OF HAMMONDS TECHNICAL SERVICES

THIS PRINT SHALL NOT BE LOANED, COPIED OR REPRODUCED IN WHOLE OR IN PART WITHOUT THE CONSENT OF HAMMONDS TECHNICAL SERVICES.

**HAMMONDS TECHNICAL SERVICES, INC.**

SCALE: **NTS**    APPROVED PART NUMBER:    DRAWN BY: **SS**

DATE: **07/21/04**    REVISED: **08/23/23**

DRAWING TITLE: **MODEL 150 DRIVER W/REDUCER**

\*GEAR RATIO 8:1 (OPTIONAL 12.5:1)    DRAWING NUMBER: **4910**

20

# Hammonds Model 150-2S, RP1 (8:1 Ratio) Injector Manual

ITEM	PART NO.	QTY.	DESCRIPTION
1	101014	1	POWER FRAME
2	101016	2	DIAPHRAGM, S
	101455	2	DIAPHRAGM, S, VITON (OPTION)
3	102001	2	FLUID END, S
4	882949	12	LOCK WASHER, #10
5	101037	8	SCREW, 10-32 x 1 1/2"
6	101842	2	CROSSHEAD GUIDE
7	101007	4	RETURN SPRING
8	101008	2	CROSSHEAD
9	101152	4	SLIDE BEARING
10	101005	2	STROKE ADJUSTMENT CAM
11	101003	2	CAM GUIDE
12	101001	2	STROKE ADJUSTMENT KNOB
13	101002	1	POWER FRAME COVER
14	101004-BW	2	LOCK SCREW
15	101009	8	SCREW, 8-32 x 3/8"
16	881088	8	LOCKWASHER, #6
17	101010	8	SCREW, 6-32 x 3/8"
18	881089	4	SCREW, 10-32 x 3/4"
18A	881660	4	SCREW, 10-32 x 2 1/4" (OPT)
19	104311	4	CHECK VALVE, 1 PSI, AFLAS
	104310	4	CHECK VALVE, 1 PSI, VITON (OPT)
	104318	4	CHECK VALVE, 1 PSI, KALREZ (OPT)
20	104315	1	CHECK VALVE, 5 PSI, AFLAS
	104314	1	CHECK VALVE, 5 PSI, VITON (OPT)
	104319	1	CHECK VALVE, 5 PSI, KALREZ (OPT)
21	101088	1	3/8 x 1/4 FNPT TUBE ADAPT

△	NEW LOCK SCREW	11/01/24	SS	JH				
△	NEW CHECK VALVES	07/10/23	SS	JH				
△	NEW CHECK VALVES	03/15/04	SS	JH				
△	SOFT SEAT CHK VLV	09/03/02	SS	JH	DRAWING	LEVELS	VIEW	
	WAS #101008	08/99	SS	X	INJECTOR	8-20, 23, 24, 27, 28,	I	
	ADDED INJ CHK VLV	01/23/98	SS	X		30-41, 45, 136		
NO.	REVISION	DATE	BY	APPVD	FROM SER#	DATE	TO SER#	DATE
					X	X	X	X

*TOLERANCES* ALL DIMENSIONS ARE IN INCHES UNLESS OTHERWISE SPECIFIED		THIS PRINT IS CONFIDENTIAL AND IS THE PROPERTY OF HAMMONDS TECHNICAL SERVICES		HAMMONDS TECHNICAL SERVICES, INC.	
*TOL. DECIMALS: .XXX= +/- .005 .XX= +/- .015 .X= +/- .030 FRAC.= +/- 1/16	*TOL. ANGLES: +/- .5 DEGREES	*CONCENTRICITY: .005 T.I.R.	SCALE: <b>NIS</b> APPROVED PART NUMBER		
SURF FINISH: <input checked="" type="checkbox"/> REMOVE BURRS AND BREAK EDGES .005 MIN.			DATE: <b>10/15/05</b>		
			DRAWING TITLE: <b>HAMMONDS 2S PUMP</b>		
			DRAWING NUMBER: <b>1170</b>		
			(1S-1S PUMP)		

# Hammonds Model 150-2S, RP1 (8:1 Ratio) Injector Manual

**\* WARNING... FAILURE TO TORQUE SCREWS PROPERLY TO 40 IN. LBS. WILL REDUCE PUMP HEAD PERFORMANCE, RESULTING IN INSUFFICIENT INJECTION RATIO.**

**11 REINSTALL SCREWS, TAKING EACH ONE DOWN BY HAND UNTIL IT STOPS. TIGHTEN SCREWS TO 40 IN. LBS. \* IN THE ORDER SHOWN BELOW. TORQUE EACH SCREW IN THE PATTERN, THEN REPEAT THE TORQUE SEQUENCE ONLY ONCE!**

**WARNING! FAILURE TO FOLLOW THIS PROCEDURE WILL RESULT IN DIAPHRAGM DEFORMATION AND PREMATURE FAILURE.**

**12 ROTATE DIAL COUNTER CLOCKWISE ENOUGH TO INSTALL DRIVE BEARING. INSTALL SNAP RING.**

**13 REMOVE DIAL KNOB. REINSTALL PLASTIC COVER. REINSTALL DIAL KNOB AND POSITION IT ON ORIGINAL % SETTING. INSTALL LOCK SCREW, LOCK DIAL IN PLACE.**

**NOTE: AFTER THIS PROCEDURE IS COMPLETE, YOU MUST RECALIBRATE THE INJECTOR TO YOUR SPECIFICATIONS.**

**FOR TECHNICAL ASSISTANCE CALL HAMMONDS TECHNICAL SERVICES (281) 999-2900**

**HAMMONDS TECHNICAL SERVICES, INC.**

SCALE	NTS	APPROVED BY:	DRAWN BY
DATE	2/11/92		REVISED 4/10/92
DRAWING TITLE		<b>"S" DIAPHRAGM REPLACEMENT</b>	
			DRAWING NUMBER
			<b>1459</b>

# Hammonds Model 150-2S, RP1 (8:1 Ratio) Injector Manual

**OPERATION INSTRUCTIONS**

- \* AT INITIAL STARTUP OR AFTER SERVICING INJECTOR PUMP, TURN VALVE POINTER TO BLEED. PLACE CONTAINER UNDER BLEED TUBE. RUN SYSTEM UNTIL CLEAR STREAM IS DELIVERED. TURN VALVE POINTER TO OFF.
- \* FOR ADDITIVE INJECTION, TURN VALVE POINTER TO INJECT.
- \* FOR NO ADDITIVE INJECTION, TURN VALVE POINTER TO OFF.

**CALIBRATION INSTRUCTIONS:**

1. INSTALL CALIBRATION BOTTLE BY THREADING IT INTO THE RECEPTACLE BELOW.
2. HAVE THE VALVE POINTER IN OFF POSITION.
3. START THE FUEL FLOW. AFTER REACHING OPERATING FLOW RATE, SWITCH VALVE TO CALIBRATE.
4. OBSERVE THE ADDITIVE LEVEL IN THE BOTTLE TO PREVENT SPILLAGE.
5. COMPARE THE AMOUNT OF ADDITIVE COLLECTED TO AMOUNT NEEDED AND MAKE ANY NECESSARY ADJUSTMENTS TO PUMP CALIBRATION.
6. CAREFULLY UNSCREW BOTTLE AND RETURN ADDITIVE TO TANK.
7. REPEAT CALIBRATION RUN UNTIL DESIRED AMOUNT OF ADDITIVE IS ACHIEVED.

FOR FACTORY ASSISTANCE WITH CALIBRATION OR FOR OTHER QUESTIONS PLEASE CALL HAMMONDS AT 1-800-582-4224

**WARNING INSTRUCTIONS:**

1. INITIAL OPERATIONS MUST BE PERFORMED BY A QUALIFIED PERSON.
2. ALWAYS WEAR PROTECTIVE GEAR.
3. ALWAYS USE THE CORRECT OPERATING PROCEDURES.
4. ALWAYS USE THE CORRECT FUEL.
5. ALWAYS USE THE CORRECT ADDITIVE.
6. ALWAYS USE THE CORRECT CALIBRATION BOTTLE.
7. ALWAYS WEAR PROTECTIVE GEAR AND RETURN ADDITIVE TO TANK.
8. ALWAYS WEAR PROTECTIVE GEAR AND RETURN ADDITIVE TO TANK.
9. ALWAYS WEAR PROTECTIVE GEAR AND RETURN ADDITIVE TO TANK.

FOR FACTORY ASSISTANCE WITH CALIBRATION OR FOR OTHER QUESTIONS PLEASE CALL HAMMONDS AT 1-800-582-4224

*TOLERANCES*		THIS PRINT IS CONFIDENTIAL		HAMMONDS TECHNICAL SERVICES, INC.	
ALL DIMENSIONS ARE IN INCHES UNLESS OTHERWISE SPECIFIED.		AND IS THE PROPERTY OF HAMMONDS TECHNICAL SERVICES		SCALE: NTS	APPROVED BY: SS
*TOL. DECIMALS:		*TOL. ANGLES:		DATE: 01/12/00	DRAWN BY: SS
.XX± +/- .005		+/- .5 DEGREES			REVISED: 03/28/24
.XX± +/- .015		*CONCENTRICITY:		DRAWING TITLE: RP1-1 INSTRUCTIONS	
.X± +/- .030		.005 I.I.R.			
FRAC. ± +/- 1/16		REMOVE BURRS AND BREAK EDGES .005 MIN.		DRAWING NUMBER: 3912	
NO.	REVISION	DATE	BY	APPVD	
1	MOVED PLUG	03/28/24	SS	JH	
2	NEW 5-WAY VALVE	11/25/08	SS	JH	
3	INITIAL RELEASE	01/12/00	SS	CH	
4	REVISION				

# Hammonds Model 150-2S, RP1 (8:1 Ratio) Injector Manual

**PARTS INCLUDED IN KITS ARE IDENTIFIED WITH →**  
NOTE: OPTIONAL O-RING ELASTOMERS ARE AVAILABLE.

ITEM	PART NO.	QTY.	DESCRIPTION
1	152074	1	CAP, ASS'Y.
2	152075	1	BODY, ASS'Y.
* 3	151002	2	O-RING, BUNA-N
→ 4	151001	1	GLASS
5	152002	1	FILTER ELEMENT
6	151005	1	PIPE PLUG, 1/4"
<b>OPTIONAL:</b>			
→ * 3	151007	2	O-RING, VITON
* 3	151027	2	O-RING, NEOPRENE
* 3	151026	2	O-RING, KALREZ
△ * 3	151020	2	O-RING, AFLAS
△ * 3	151002-EX	2	O-RING, EXT TEMP BUNA
7	102787	1	1/4" CHK VLV, 5 PSI, AFLAS
→ △ 7	881715	1	1/4" CHK VLV, 5 PSI, VITON
7	102644	1	1/4" CH VLV, 5 PSI, KALREZ

△	EXTR TEMP O-RING	03/18/25	SS
△	CAP REVISED	02/03/23	SS
△	ADDED AFLAS OPT	07/21/21	SS
△	ADDED KIT INFO.	07/02/18	SS
△	ADDED VITON C/V	05/23/14	SS
△	ADDED CHECK VALVE	05/23/14	SS
△	INITIAL RELEASE	07/23/84	SS
NO.	REVISION	DATE	BY

DRAWING	LEVELS	VIEW
0159	1, 2	1
FROM SER#	DATE	TO SER#
X		X

*TOLERANCES*	
ALL DIMENSIONS ARE IN INCHES UNLESS OTHERWISE SPECIFIED.	
*TOL. DECIMALS:	*TOL. ANGLES:
.XXX± +/- .005	+/- .5 DEGREES
.XX± +/- .015	*CONCENTRICITY:
.X± +/- .030	.005 T.I.R.
REMOVE FILPS AND BREAK EDGES .005 MIN.	

THIS PRINT IS CONFIDENTIAL AND IS THE PROPERTY OF HAMMONDS TECHNICAL SERVICES

**HAMMONDS TECHNICAL SERVICES, INC.**

SCALE: NTS      APPROVED BY: **152011**      DRAWN BY: SS

DATE: 07/23/84      REVISED: 03/18/25

DRAWING FILE: **SIGHT FLOW INDICATOR, STD.**

DRAWING NUMBER: **0159**



# Hammonds Model 150-2S, RP1 (8:1 Ratio) Injector Manual

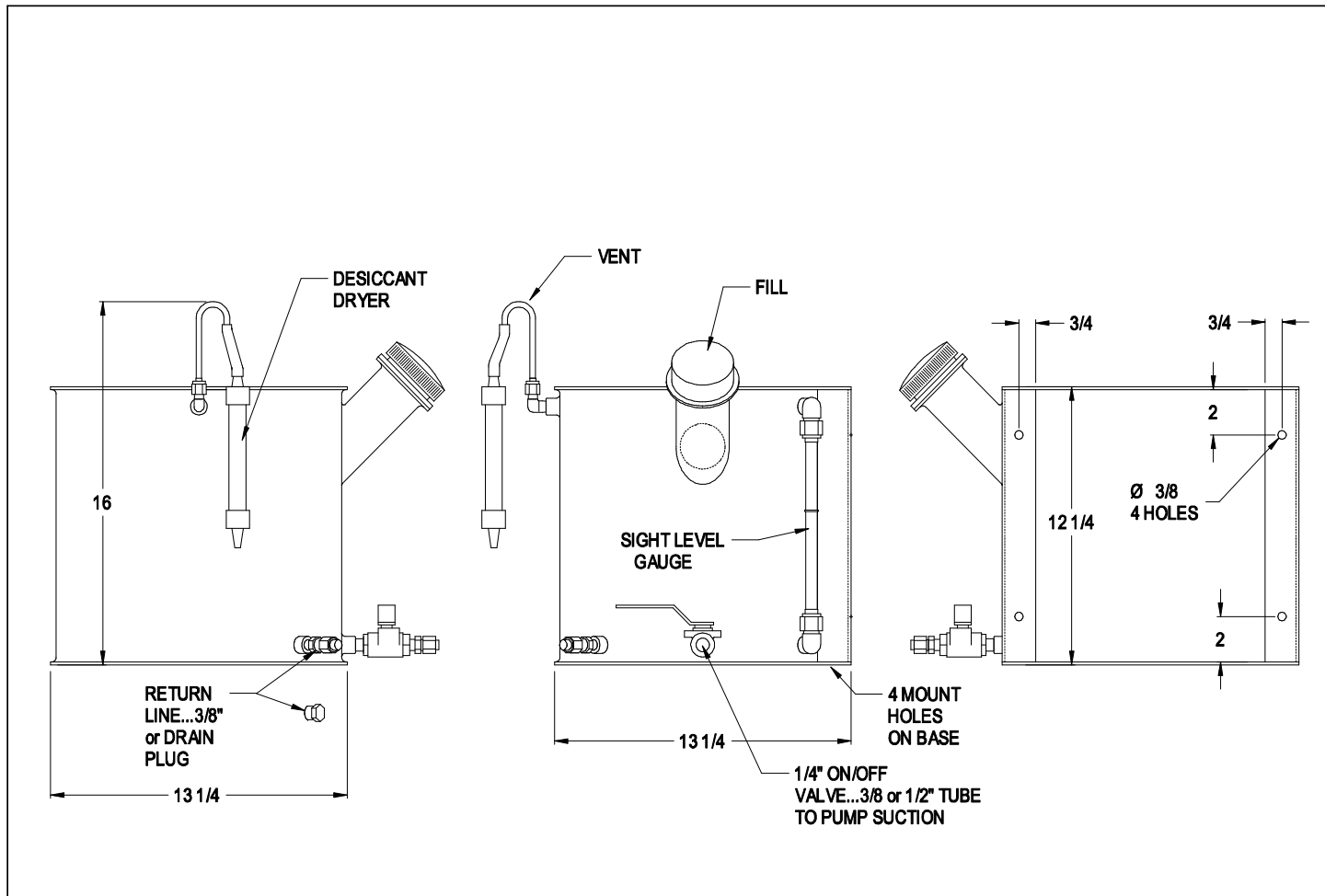

<table border="1" style="width: 100%; border-collapse: collapse;"> <tr> <th>DRAWING</th> <th>LEVELS</th> <th>VIEW</th> </tr> <tr> <td>6GAL</td> <td>12, 13</td> <td>I</td> </tr> </table>				DRAWING	LEVELS	VIEW	6GAL	12, 13	I	<p><b>*TOLERANCES*</b> ALL DIMENSIONS ARE IN INCHES UNLESS OTHERWISE SPECIFIED.</p> <p>*TOL. DECIMALS: .XX± +/- .005 .XX± +/- .015 .X± +/- .030 FRAC. = +/- 1/16</p> <p>*TOL. ANGLES: +/- .5 DEGREES</p> <p>*CONCENTRICITY: .005 T.I.R.</p> <p>*REMOVE BURRS AND BREAK EDGES .005 MIN.</p>				<p>THIS PRINT IS CONFIDENTIAL AND IS THE PROPERTY OF HAMMONDS TECHNICAL SERVICES</p>				<p><b>HAMMONDS TECHNICAL SERVICES, INC.</b></p>																							
				DRAWING	LEVELS	VIEW																																			
6GAL	12, 13	I																																							
<table border="1" style="width: 100%; border-collapse: collapse;"> <tr> <td>NO.</td> <td>REVISION</td> <td>DATE</td> <td>BY</td> <td>APPVD</td> </tr> <tr> <td></td> <td></td> <td></td> <td></td> <td></td> </tr> </table>				NO.	REVISION	DATE	BY	APPVD						<table border="1" style="width: 100%; border-collapse: collapse;"> <tr> <td>SCALE</td> <td>NTS</td> <td>APPROVED PART NUMBER</td> <td>DRAWN BY</td> </tr> <tr> <td>DATE</td> <td>09/13/05</td> <td>6GALL</td> <td>SS</td> </tr> <tr> <td colspan="4">DRAWING TITLE</td> </tr> <tr> <td colspan="4" style="text-align: center;"><b>6 GALLON TANK ASSEMBLY</b></td> </tr> <tr> <td colspan="3">SIDE FILL...ROTATED</td> <td>DRAWING NUMBER</td> </tr> <tr> <td colspan="3"></td> <td>5269</td> </tr> </table>				SCALE	NTS	APPROVED PART NUMBER	DRAWN BY	DATE	09/13/05	6GALL	SS	DRAWING TITLE				<b>6 GALLON TANK ASSEMBLY</b>				SIDE FILL...ROTATED			DRAWING NUMBER				5269
NO.	REVISION	DATE	BY	APPVD																																					
SCALE	NTS	APPROVED PART NUMBER	DRAWN BY																																						
DATE	09/13/05	6GALL	SS																																						
DRAWING TITLE																																									
<b>6 GALLON TANK ASSEMBLY</b>																																									
SIDE FILL...ROTATED			DRAWING NUMBER																																						
			5269																																						