

TABLE OF CONTENTS

Specifications.....	2
How The System Works.....	3
Description of Major Components.....	4 - 5
Preparation for Start-up & Priming the System.....	6 - 7
Connecting the Additive Tanks and FSII Drum.....	8
System Layout Drawing.....	9
Calibrating The System.....	10 - 11
Normal Operation.....	12
Shutdown and Preparation for Storage.....	13
Trouble Shooting the System.....	14 - 19
Preventative Maintenance.....	20 - 22
Assembly and Disassembly Instructions.....	23 - 31
Major Internal Pump Service.....	32 - 33
Diaphragm Service Instructions - CI and SDA.....	34
Diaphragm Service Instructions - FSII.....	35
CI & SDA Pump - Exploded View (Size “S” Pumps).....	36
Assembly Drawing and Parts List for CI & SDA.....	37
FSII Pump - Exploded View (L Pumps).....	38
Assembly Drawing and Parts List for FSII (L Pump).....	39
Assembly Drawing and Parts List for Fluid Motor.....	40
Assembly Drawing and Parts List for 3:1 Gear Reducer.....	41
Assembly Drawing and Parts List for Small Sight Flow Indicator (CI and SDA).....	42
Assembly Drawing and Parts List for Large Sight Flow Indicator (FSII).....	43
Assembly Drawing and Parts List for System Components.....	44

SYSTEM SPECIFICATIONS

Model Number: Hammonds 4T-4A

Description: Portable, multi-additive injector

Size: 31" wide X 45" long X 26" high

Weight: 296 pounds

Product Connections: 4" Cam-lock connections

Additive Connections: CI and SDA - 3/8" tube fittings or 1/4" female pipe threads
FSII 3/4" tube fitting or 3/4" female pipe threads

Fuel Flow Operating Range: 40 - 600 GPM

Injection Ratio Capacity: CI and SDA - 75 PPM
FSII - 2100 PPM

Duty Cycle: Continuous

Elastomers:

- Additive Injection Diaphragms are Teflon®
- Mechanical Seal: Ceramic on Carbon
- O-rings, static seals - Neoprene
- Injection Check Valves - Aflas®

Materials of Construction:

- Fluid Motor: Anodized aluminum
- Motor Rotor: Anodized aluminum
- Motor Shaft: Stainless Steel
- Injectors: All wetted parts stainless steel
- Additive Manifolding: All wetted parts stainless steel

Operating Environment: Out of Doors

Operating Temperature Range: -20° F to +115° F

HOW THE SYSTEM WORKS

The 4T-4A is a fluid powered, multi-additive injection system. The 4T-4A provides proportionate-to-flow additive injection by borrowing enough energy in the flowing jet fuel line to turn the fluid motor. As fuel flow increases or decreases in volume, the fluid motor responds by turning faster or slower.

Since the all three injectors are directly linked to the fluid motor, they also increase and decrease in speed with the flow of fuel as it passes through the system and are therefore *proportionate-to-flow*. After the injectors are calibrated at a given fuel flow rate, they remain at the same injection ratio throughout the flow range of the system. For example, if the injectors are calibrated to deliver a certain injection ratio at 300 gpm, the system will remain in calibration at any flow rate from 40 - 600 gpm.

The 4T-4A is both powered and controlled by the flow of fuel passing through the fluid motor. No external power or a meter is required for operation. The system is “passive”. When fuel flow begins, injection begins. When flow slows or stops, injection slows or stops proportionately, with no action required from the operator. All that is required is fuel passing through the system and a supply of additives.

DESCRIPTION OF MAJOR COMPONENTS

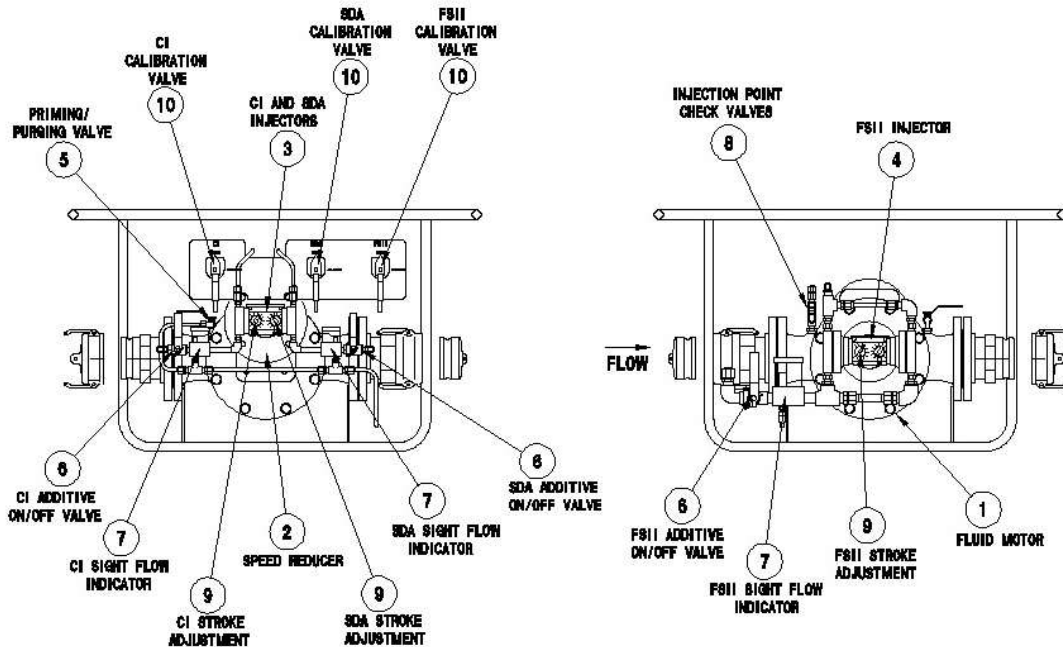

1. **FLUID MOTOR:** The fluid motor borrows just enough energy from the flowing fuel to power the three additive injectors.
2. **SPEED REDUCER:** Since the CI and SDA additives are injected at a very low ratio, these two injectors operate at a much slower speed than the FSII injector. The fluid motor speed is reduced by this reducer at a 3:1 ratio, making it possible to calibrate the CI and SDA injectors at a very low ratio.
3. **CI AND SDA INJECTORS:** These injectors share a common power frame with one fluid end dedicated to each additive. Although mounted together in the same frame, each operates completely independent of the other. Both pumps include a stroke adjustment and each a separate additive source. Either injector may be turned off by closing the additive valve or adjusting the stroke adjustment to zero.
4. **FSII INJECTOR:** Since FSII is injected at a high ratio (1000 - 2000 PPM or 1 - 2 gallons per 1000 gallons of fuel) a high capacity injector is required. The FSII injector uses two large pump heads that are connected together for combined output. Although each pump head has a separate stroke adjustment and can be adjusted independently, both are usually set about the same to keep the system balanced. In an emergency, one of the heads operating at near full capacity could inject the required ratio of FSII with the other head stroke adjustment set to zero.
5. **PRIMING/PURGING VALVE:** Since systems arrive empty, and are often stored for long periods of time, a means to prime the system initially and to purge or clean the system out prior to storage is provided. With fuel lines connected and flowing, the Prime/Purging valve takes fuel from the product line, under pressure and is used to feed all three injectors. By opening the valve, the manifolding and fluid ends are filled almost instantly. Prior to storage,

the system can be purged of all additive with the same procedure. CI and SDA are particularly bad about drying in the pumps and lines, forming a thick, sticky residue that is very difficult to remove the next time the system is used. If the system is not purged before storage, it would likely be necessary to completely disassemble the pumps and clean them prior to the next use.

6. ADDITIVE ON/OFF VALVE: This valve is used to interrupt the supply of additive between the additive tank and the injector. It can be turned off at any time without harm to the pump. The units are transported and stored with all three of these valves in the closed position.
7. SIGHT FLOW INDICATOR: The Sight Flow Indicator serves a three-fold purpose. First, it allows the operator to monitor the presence of additive in the system. Second, it allows the operator to observe the exact amount of additive being injected into the system. Unlike some flow indicators that move wheels or rattle balls, the Sight Flow Indicator shoots the additive up out of the tube as it is drawn into the injector. Since every drop of additive that the injector pumps must pass through this indicator, this device provides proof positive that additive is moving into the system. The operator can see the additive as it is being drawn into the pumps. Finally, the Sight Flow Indicator has a screen filter. And since the walls of the indicator are glass, it is possible to observe the condition of the filter during operation and perform preventative maintenance when required.
8. INJECTION POINT CHECK VALVES: These valves are special valves with soft seat elastomers that prevent jet fuel from migrating back into the injectors while allowing additive to be injected into the fuel. There is a separate line check valve for each additive. (a total of three)
9. INJECTOR STROKE ADJUSTMENTS: The stroke adjustments allow the length of stroke of each pump fluid end to be adjustable throughout its range.
10. THREE WAY CALIBRATION VALVES: These three way valves are provided for each additive. The valve has two positions; *inject and calibrate*.

PREPARATION FOR START-UP PRIMING THE SYSTEM

It is necessary to fill the additive lines, the Sight Flow Indicator and the pump fluid ends with additive prior to operation. Although the injectors would eventually prime themselves, the process would take time and require running a large amount of product through the system and the pumps would be required to purge the air from the system.

There are two ways to prime the system. The permanent built in priming system uses the pressure of jet fuel in the product line. The accessory priming hose and bulb can be used to manually fill the system with additive if fuel flow is not available prior to operation.

PRIMING WITH THE ON-BOARD PRIMING SYSTEM

After fuel has been connected to the system and pressurized, connect the additive lines to all three injectors. First, be sure the valve between the additive tank and the Sight Flow Indicator is closed on each injector. Next, place the priming valve in the open position as shown while running fuel through the system. Beginning with any one of the injectors, hold a graduated container under the calibration tube and turn the 3-way calibration valve to the *Calibrate* position. The pump will prime within a few seconds and begin discharging fuel from the tube. Allow the pump to operate until there is an air-free stream of fuel being pumped from the calibration tube. Return the 3-way valve to the *Inject* position. Now, do the same with the other two injectors.

When all three injectors have been primed, turn the *Priming valve* to the closed position. The supply valves between the tanks and injectors can now be re-opened. The injectors will quickly pick up the additive from the tanks. The system is now ready for calibration.

Priming/purge valve is shown in the *open* position.

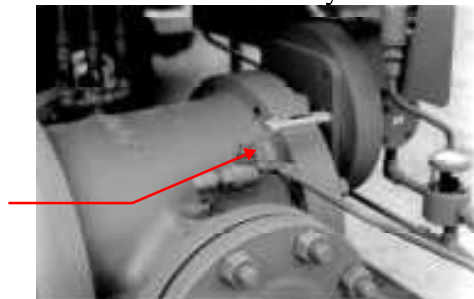

CAUTION
The priming/purge valve must be in the *closed* position during normal operation.

The priming/purge system is connected to each of the additive injectors through the bottom of the Sight Flow Indicators. To prevent additive from migrating into the priming manifold, a check valve is installed at each Sight Flow Indicator. In the unlikely event that one of these valves would leak, the additive delivery system would not be affected since the main Priming/purge valve is always off during normal injection.

PRIMING WITH THE ACCESSORY PRIMING BULB AND HOSE

If pressurized fuel is not available during preparation or the system cannot be operated, the portable priming bulb and hose can be used to fill the system with additive. Select the first injector to be primed and open the valve between the tank and the injector. Note, there may be two valves. One on the tank itself and one at the Sight Flow Indicator. Be sure both are opened.

Slip the *short* end of the priming hose over the discharge tube below the 3-way valve of the pump to be primed. Notice the arrow indicating flow on the priming bulb. Be sure it is pointing to the direction *from* the tube. Place the long end of the hose in a graduated container and *slowly* squeeze the priming bulb until fluid is discharged from the tube. After additive begins discharging from the long end of the hose, continue to squeeze the bulb until there is no air remaining in the discharge. Turn the 3-way valve to the *inject* position. The pump is now primed. Repeat this process for the other two injectors.

Note: The FSII injector may require considerable priming effort using this method since the pumps are very large and the line leading to the drum of additive is much larger and displaces considerable area. If the drum is sitting on end vertically, it will be still harder to prime the system. After the pump heads have been fully primed, they will remain primed even when the system is stopped intermittently

Be sure the arrow on the bulb is pointing to the calibration bottle

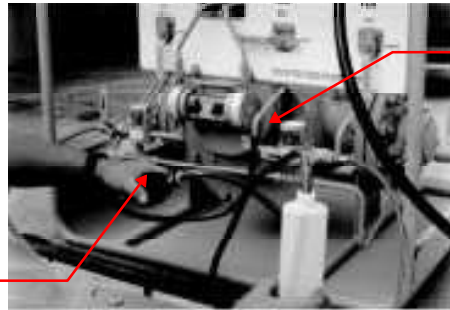

Slip the short end of the hose over the tube at least 1/2" to prevent vacuum leaks

THE IMPORTANCE OF PRIMING THE SYSTEM

All fluid pumps perform well only if supplied with adequate fluid. Air is the single greatest enemy of any pump. If the system is not properly supplied with a solid, air free supply of fluid, the pump can become air locked and either perform poorly or not at all.

Remember, the CI and SDA pumps operate at very low output (about 20 PPM). The pumps have a maximum stroke length of only 3/16" and discharge only drops of additive with each stroke. If air is in the system, the pumps cannot perform properly and they are even less able to pull a suction from a distance. ***A COMPLETE, AIR FREE PRIME TO THE INJECTORS WILL GUARANTEE THE BEST POSSIBLE PERFORMANCE.***

CONNECTING THE ADDITIVE TANKS AND FSII DRUM

The 4T-4A *must* have a good supply of additive in order to perform properly. This includes using proper tanks and making certain that the tank and injector are connected with leak free tubing of adequate size to carry the additive to the injector. *Remember: pumps do not suck fluid, they **push** the fluid that is supplied to them. Do not rely on the pumps to pull additive from long distances or up-hill. Additive should be supplied on a gravity basis with the inlet of the injector always flooded.*

Simply stated, the bottom of the additive supply should be at least as high as the inlet of the injector and preferably a little higher. In the case of the CI and SDA tanks, supply is very important since the ratio is so small. The tanks should be placed on top of the system as indicated for best results. The FSII can be stood vertically or horizontally. Ideally, the drum should be elevated as well.

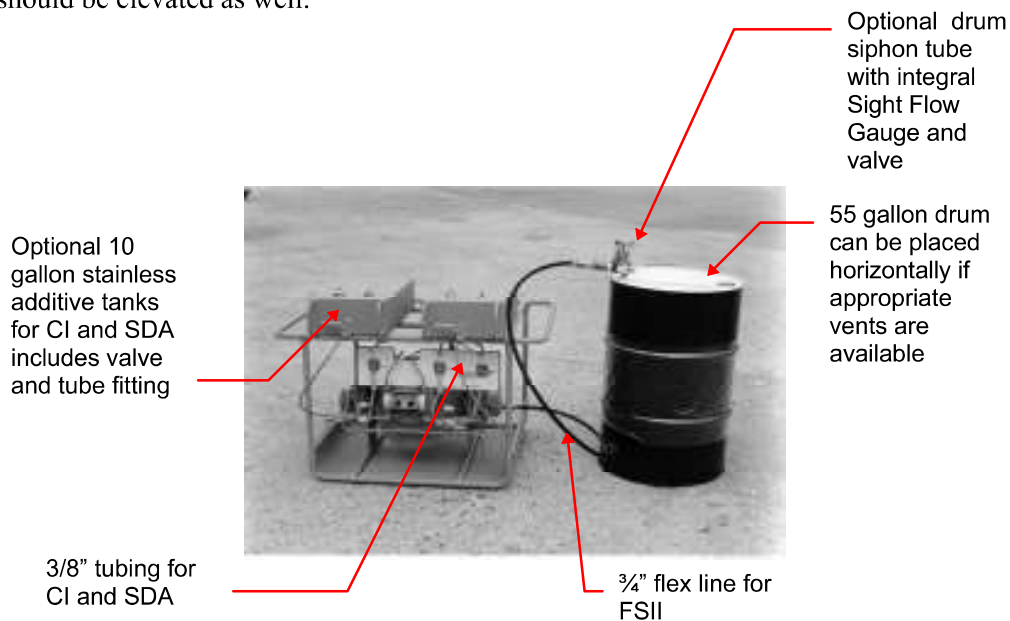

CAUTION
Be sure all tube fittings match those on the system and are tight to provide a leak free connection

IMPORTANT RULES FOR CONNECTING ADDITIVE SUPPLIES

- Make sure tanks are level with or above the injector inlet
- All tubing must be 3/8" for CI and SDA and 3/4" for FSII
- Tube fittings must match those on the system
- All connections must be air tight. Remember, there is a vacuum on the suction side of each pump. The connection can be leaking without visible additive leaks. Vacuum leaks will cause erratic operation or failure.

Watch your additive levels and do not allow the system to run dry. If the system runs out of additive, re-priming will be necessary.

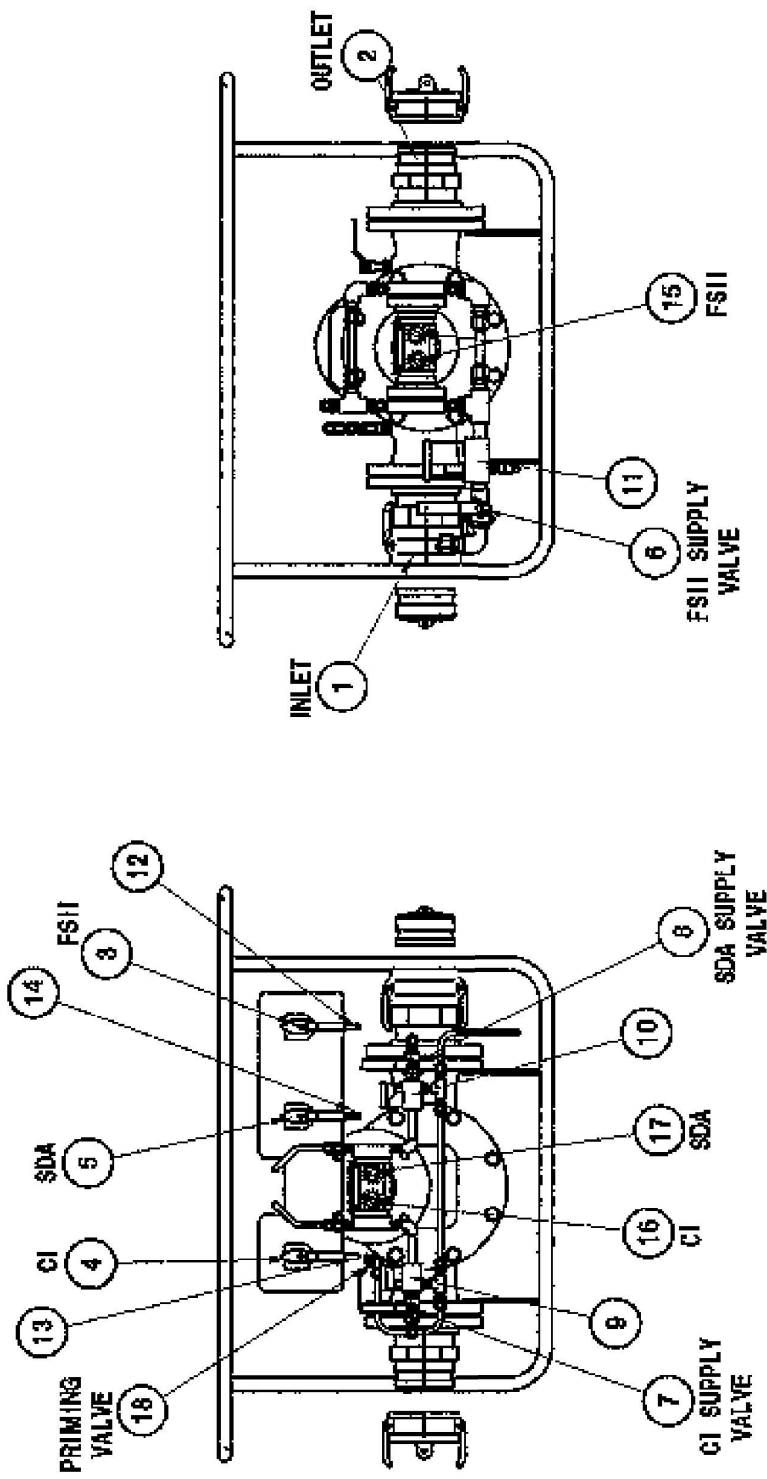

CALIBRATING THE SYSTEM

Refer to Illustration on Opposite Page

1. Place the unit on level ground
2. Connect the three (3) additive supplies to the system (see “*Connecting the Additive Tanks and FSII Drum*”)

CAUTION

Be careful not to get dirt in the hoses or hose connections.

3. Be sure injectors are primed (see “*Priming The System*”)
4. Turn supply valves #6, #7, #8 to the OFF position.
5. Connect the fuel supply hose to the injector inlet #1 and fuel outlet hose to the injector outlet #2.
6. Start the fuel flow. Calibration flow should be a minimum of 150 GPM
7. Turn the supply valves #6, #7, & #8 to the ON position.
8. With the system operating, check sight flow indicators #9, #10, and #11 for steady flow through the vertical tubes.
9. Check the vents on all three additive tanks/drum and be sure they are open

CALIBRATION

10. Choose one of the additives to be calibrated. Check the recommend add rates and determine the amount of additive that should be injected for a given amount of fuel. Since the add rate for FSII is large, use 100 - 200 gallons as a test. For CI or SDA, a 500 gallon test is easier to measure.
to the additive to be calibrated ON, with the others in OFF.
11. Open the valve to the additive being calibrated. Close the others.
12. Turn the calibration valve to the additive being tested to the calibrate position.
13. Hold a graduated container under the appropriate calibration output tube (12, 13, or 14). Start the unit and pump the desired amount of fuel through the system while catching the amount of additive delivered in the bottle.
14. Compare the quantity collected in the bottle to the calculated amount. Adjust the appropriate injector stroke adjustment to increase or decrease the output depending on the result. Repeat the test until the exact amount is delivered. Repeat this same procedure with all three additives, making certain to lock the adjustments securely with the lock screws located below each of the stroke adjustment knobs.

NOTE: These calibration procedures measure the amount of additive being discharged from the system under *no discharge pressure* since the additive is discharged into an open container at atmospheric pressure. Because the system actually pumps under some pressure higher than atmospheric (usually between 15 - 50 psi), there will be some difference between the collected amount of additive and that injected under pressure.

This difference should be taken into consideration. Since this difference will change depending on varying pressures and flow conditions, it is impossible to provide specific tables. FSII injection can be verified through the use of refractometer tests. SDA levels can be verified with a conductivity meter. There is currently no field test for determining CI levels, so volumetric comparison of fuel handled vs. additive consumed is the best double check for this additive.

NORMAL OPERATION

Following initial start-up and calibration, the system requires very little attention other than making certain that additive tank levels are maintained. Operators will quickly become accustomed to the performance of the system by observing the Suction Sight Flow Indicators. On-spec injection will cause a certain response in the indicators, and with some practice, operators will be able to observe the system and qualify performance at a glance. *This does not mean that system calibration should not be periodically checked!* However, during a busy work load, these visual checks will provide assurance to the operator that the system is functioning.

Assuming the system remains set up and operating at least intermittently, calibration is required perhaps every 1 - 3 months. Good record keeping of additive inventory and use levels compared to fuel handled can give a good indication that additive is on specification. Tests such as the refractometer for FSII content should be the final test to verify additive injection ratios.

See the section on preventative maintenance for suggestions as to regular maintenance.

SHUTDOWN AND PREPARATION FOR STORAGE

ANY additive left in the system for prolonged periods of storage will solidify and cause the unit to fail. Therefore, for any period of extended storage, be certain the system is completely purged of all additive. Using the Prime/Purge valve, it takes only a few minutes to completely clean the system for storage. Follow these directions carefully.

1. Turn off the additive supply valves # 6, # 7, and # 8.
2. If the unit is going to be inoperative for more than one week in normal summer time temperatures, or for more than 72 hours in temperatures less than freezing, the injectors should be purged of all additive with jet fuel. This is accomplished by closing the supply valves # 6, # 7, and # 8 and opening the priming valve # 18 for 30 seconds while the system is operating. After 30 seconds, turn off the fuel flow and turn off the priming valve # 18.
3. Disconnect additive supply lines from additive tanks and store the lines.
4. Make certain calibration valves # 3, # 4, and # 5 are in the inject position.
5. Disconnect inlet and outlet fuel hoses and tip unit up first on one end and then the other to drain trapped fuel from the fluid motor. Use a container to catch the trapped fuel drained from the system.
6. Replace the dust covers.
7. If possible, dispose of additive remaining in additive tanks and close tank vents.
8. Replace covers and re-install safety latch pins. Unit is ready for transport and or storage.

CAUTION

FAILURE TO FOLLOW THESE PROCEDURES MAY MAKE THE SYSTEM IN-OPERATIVE DURING THE NEXT USE. A SYSTEM STORED WITH ADDITIVE REMAINING IN THE INJECTORS WILL REQUIRE HOURS OF DISASSEMBLY AND CLEANING PRIOR TO USE AND COULD JEOPARDIZE THE SAFETY AND SUCCESS OF YOUR MISSION.

TROUBLE SHOOTING THE SYSTEM

SYSTEM WILL NOT TURN

- Fuel hoses have been connected incorrectly making fuel pass through the system in the wrong direction.

Note flow arrow cast in top of motor casting, fuel flow must be in same direction



- A fuel hose is kinked upstream or downstream of the system
- A valve up-stream or downstream of the system is partially or fully closed
- A line check valve is installed in the wrong direction upstream or downstream of the injector. Sometimes, check valves are left in a hose system accidentally that were there for other reasons in a previous exercise. Be sure none exist.
- A pressure control valve at some point in the fuel system is set too low and not providing the flow / and or pressure to power the injector. Some systems have pressure control systems built in to prevent over-pressurizing an aircraft. These may be set too low for normal fuel transfer operations.
- Somehow, the fuel hose has been connected to the suction rather than the discharge side of the main fuel delivery pump. It's easy to do, some field operations may have several hoses routed from place to place. Check each end of every hose and be sure it is connected to the correct outlet.
- A rag, glove or other foreign object is jamming the injector. Check the inlet side first and using your hand, see if the fluid motor will rotate freely. It is somewhat difficult to turn, but it can be done.
- Check the pumping system thoroughly. There can be many reasons that a pump is not delivering the appropriate flow such as loss of prime, pressure controls not set properly, or relief valves not adjusted allowing flow to by-pass the system when under pressure.

SYSTEM TURNS BUT WILL NOT PICK UP ADDITIVE

- Check additive level in tank. If a drum is being stood on end, the siphon tube may not reach the bottom of the drum. Some additive may remain but be below the suction tube, starving the injector.
- Make sure all valves are opened. Check valves on the tanks and the suction discharge valve.
There is a suction leak in the hose connections between the injector and tanks. The fittings on the Hammonds 4T-4A are all stainless steel. They form a

metal-to-metal seal and therefore must be very tight. Be sure to use a backup wrench and check each fitting for tightness. Remove the hose from the connections and be certain that the hose extends about 3/16" past the end of the collet. If the hose is only even with the collet, it will leak. The hose should extend about 1/4" beyond the collet. Use proper fitting tightening procedures illustrated below.



Always use two wrenches to back up both parts of the fitting. It is important *not* to disturb the threaded portion of fittings when loosening or tightening tube fittings.

- The tank vent is closed causing a vacuum in the tank. Open vent on tanks. FSII drum must be vented also.

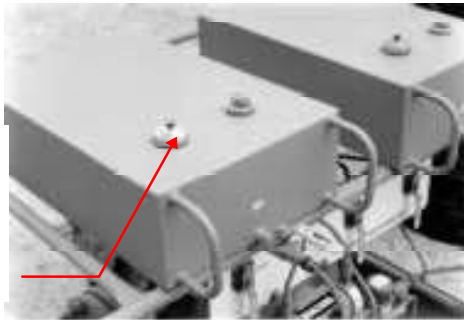

Be sure vent on top of fill cap is open.

- A Suction Sight Flow Indicator is leaking around the seals. Remove the cap and check the large o-rings on top of the clear glass. Use a small amount of grease or oil to coat each o-ring, replace the glass and hand tighten the cap.



- Check the screen located in the Suction Sight Flow Gauges for foreign material. If needed, remove the cap, glass and clean the screen



- A pump has been stored with additive in the system and dried the check valves in the open position. Try to purge the system by closing all three additive supply valves, then open the Priming/Purge valve and allow the system to operate for a few moments. The fuel should clear the clogged valve. Turn the Priming/Purge valve OFF and turn the supply valves back ON. Observe the performance.
- A check valve has been fouled with a piece of Teflon® tape or other trash. This is usually on the suction side of the pump (the valve on the bottom of the fluid end). As a last resort, remove the valve and check for fowling. Be sure and re-seal the pipe fittings with tape and pipe dope if all possible.

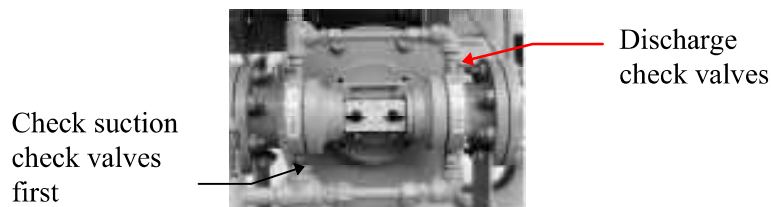

- A diaphragm is broken. An old worn diaphragm can begin to loose efficiency before it fails completely and begins to leak. First, the fastener in the diaphragm pulls free of the diaphragm. This causes the pump to operate partially on the pressure stroke, but not on the suction stroke, which enables the pump to receive fluid. Performance is reduced by about 50% and the pump will refuse to pull additive into the fluid end fully. If the problem pump is either CI or SDA, check the appropriate diaphragm. If it is the FSII system, first turn the stroke down on one side, then the other and in this way determine which fluid end is causing the greatest amount of loss in performance. In the case of the FSII injector, if one diaphragm is faulty, chances are, both should be replaced, even if the remaining one seems ok. They each have the same amount of wear since new. Be sure to follow the instructions on replacing the diaphragms carefully found in the maintenance and repair section.

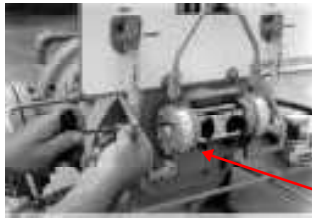

Check for leaks between pump power frame and fluid end

- The additive supply hose has a pin hole leak that is not visible. Since there is a vacuum present on the suction side of the injectors, it is possible to have a leak in the hose without seeing a visible leak. These leaks are very hard to detect, and will only leak when the unit is not operating. A leaking hose may only show up as a dampness on the hose exterior. Ultra violet, temperature and abrasion are hard on additive hoses.
- Check stroke adjustments and make sure the locking screw has not vibrated loose and allowed the adjustment to move. If the stroke adjustment cam is not securely locked in place, it will have a tendency to move back to “O” on it’s own. Check the stroke adjustments to sure they have not vibrated loose during shipment or from the previous use.



The CI & SDA pumps use thumb screws for locking the stroke adjustment, while the FSII has allen sets. CAUTION *do not over-tighten the allen head set screws, as doing so will damage or break the cam.*



INJECTORS ARE PRIMED, SYSTEM IS TURNING BUT INJECTION IS EITHER LOW OR ERRATIC

- Check additive levels
- Check connections including tube fittings on each end of each additive hose
- Check vent on tanks, must be open
- Check screen in Suction Sight Flow Indicators
- Be sure all valves in additive line are fully open
- Make sure stroke adjustments have not slipped
- Check the diaphragm. A diaphragm may not be leaking but still need replacement.
- Check the check valves, particularly the suction valves on the bottom of each fluid end in question for trash or sludge from previous dried additive left in the system.
- Check the performance ratio of fluid motor. The fluid motor will rotate .4 revolutions for every gallon of fuel that passes through the system. Establish a flow rate in GPM, remove the **FSII** pump stroke adjustment covers, and count the revolutions for 30 - 60 seconds. Example: 400 GPM X .4 = 160 rpm. If the counted rpm is off more than 20%, the fluid motor may have

excessive wear internally and need vane replacement. Note: Do not count the output shaft rotations on the CI and SDA pumps. This shaft exits a 3:1 reduction. The FSII pump operates at direct 1:1 motor speed.

- Check stroke adjustment knobs on the injectors when the system is running. If the screws that secure the various power frame parts have worked loose, the stroke adjustment cam and knob will move about. Remove the knob, cover and check the fasteners. See exploded view of the system in the maintenance section.
- CI and SDA additives may be too thick due to low temperature and out-of-ratio blending. In most cases, neat (concentrated) CI and SDA are blended with jet fuel at ratios of 19:1. This enables the ratio to be injected at 20 ppm rather than 1 or 2 ppm. The higher ratio is much easier to calibrate and measure under field conditions. If this “cocktail” is not mixed properly, or if the additive has been exposed to atmosphere for long periods of time, the viscosity (thickness) of the additive may have increased making it difficult to pump.
- Temperature is too low causing the additive to be hard to feed. If the additive cannot be warmed for thinning, it may be necessary to increase the stroke during the colder temperatures.
- Remember: 99% of all pump problems occur because of suction problems.

THE INJECTOR IS RUNNING SLOW EVEN WITH HIGH FUEL FLOW RATES

- Vanes may be excessively worn. See previous section on checking motor ratio.
- Check the system flow rate. The system does not reach optimum efficiency until the rate exceeds 40 gpm. Be sure the pump system is delivering the proper volume of fuel. Since fuel handling is most often associated with equipment that generate high noise levels, you cannot depend on the sound of the injector to indicate fuel flow rate.

THE INJECTOR WILL NOT FLOW AT ALL AND APPEARS TO BE LOCKED UP

- The motor has thrown one or more of the vanes. Remove the FSII side cover plate and inspect the vanes.
- Check the inlet for foreign objects such as rags or gloves.

THE INJECTOR HAS BEEN DISASSEMBLED AND RE-ASSEMBLED BUT NOW WILL NOT TURN AT ALL REGARDLESS OF FUEL FLOW RATES.

- The rotor has been installed backwards allowing flow to pass around the rotor and vanes without causing rotation. See the illustration below. If necessary, remove the rotor, and orient the vanes correctly.

Illustration shows FSII pump and side plate removed, exposing fluid motor internals and configuration of rotor and vanes.

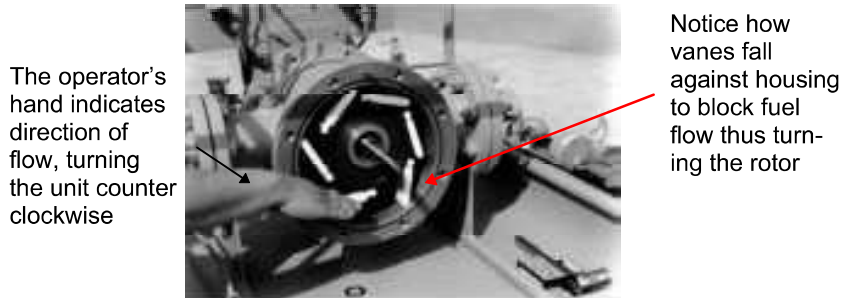

- The hoses have been connected incorrectly. The system will operate with fuel passing through the system in one direction only. See the arrow molded into the top of the fluid motor housing. Reverse hoses if necessary.

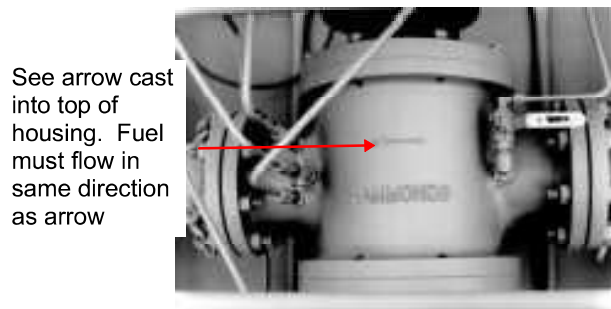

.....*a few tips to remember*

- Pumps do not *suck* fluid, they *push* the fluid. Additive *must* be supplied to the pump. This is called providing a *flooded suction*. Although the injectors can be forced to lift, they work best when flooded with a supply of additive.
- 99% of all pump problems result from problems on the *suction* side of the system. That is, within those components between the additive tank and the injector, and that includes the tank. Leaks, obstructions, anything that can restrict the free flow of additive to the system will effect how the system works.
- The 4T-4A is powered by fuel. Without fuel flow, there is no injection. There can be many components in the system before and after the 4T-4A that can effect the flow of fuel. Be sure you have adequate flow to the system before deciding that something is wrong.
- Take a few minutes to study and understand how the system works.

PREVENTATIVE MAINTENANCE

FLUID MOTOR

- Be sure the motor inlet and outlets are kept closed to dust and dirt
- Check seal vent holes in each side of the fluid motor as illustrated below for any signs of jet fuel. There is a mechanical seal on each end of the motor shaft. If this seal begins to leak, fuel will leak from these holes. Mechanical seals will not normally fail suddenly, but begin to *weep* slowly, with the leak gradually getting worse over a period of time.

Check drain hole in bottom of rounded housing for signs of fuel leakage

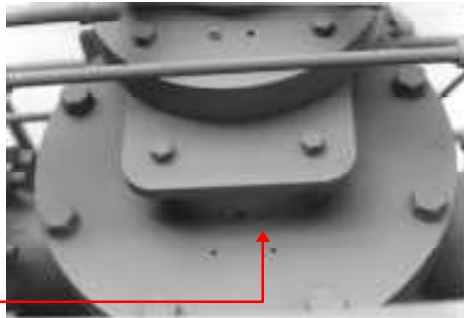

- The internal fluid motor and seals require no preventative maintenance unless the system shows signs of not performing properly or leaking. Providing the system is not operated at flow rates above 600 gpm, and foreign material such as dirt or sand has not been allowed into the system, the main drive vanes in the fluid motor will last for hundreds of hours of trouble free operation. A gradual reduction in motor performance will occur with age, but can be compensated for by increasing injection pump settings. It is suggested that major maintenance on the fluid motor be done only when a fuel leak is present or if the injectors cannot be calibrated to specification.

INJECTOR GEAR REDUCER

- The CI and SDA injectors are driven through a 3:1 ratio gear reducer. The gears in the reducer are packed at the factory with grease. Additional grease can be added with a conventional grease gun on the zerk as indicated below. Grease this fitting after every 100 hours of operation. Inject grease until excess exits the hole next to the zerk fitting. Wipe off excess so that dirt will not be attracted. See following illustration showing CI and SDA side of system.

Use a conventional grease gun with chassis grease every 100 hours

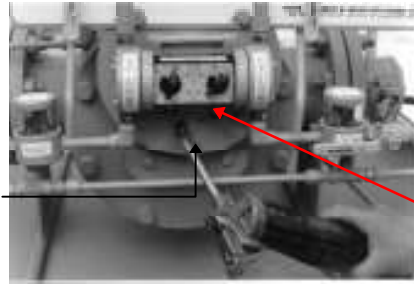

Inject grease until excess exits the hole next to the zerk fitting. Wipe away excess

INJECTOR MAINTENANCE

- Grease the area around the drive bearing on both pumps with waterproof grease as indicated. Fill the cavity between the round bearing and cross head as well as the area between the cross head and pump power frame. If grease appears to be contaminated with dirt or sand, the area should be flushed with solvent and fresh, clean grease applied. Check this area every 50 hours or as needed depending on the operating environment.

Fill area around bearing with water proof grease

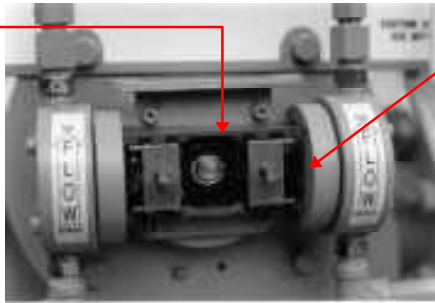

Fill area between cross head and pump power frame with grease.

- The life of diaphragms vary with application. CI and SDA diaphragms can last for millions of gallons of fuel since they operate very slowly and at a very short percentage of stroke. The FSII pumps may however, need replacement sooner. Diaphragms used every day on an intermittent basis typically last from one to two years. Spare diaphragms should be on hand during extended deployment (over 6 months) or under severe operating conditions (over 6 hours per day). It is a good policy to replace all diaphragms following an exercise, assuring that the system will be fresh following storage for the next deployment. For equipment that is used daily in a semi-permanent operation, it is suggested diaphragms be replaced every 12 months as regular maintenance.
- The internal parts of the injectors will typically last for many years. The CI and SDA pumps use aluminum parts, while the FSII pump uses all stainless steel components. Keep these parts greased and all fasteners tight.
- Check valves (two on each pump) will normally perform for hundreds of hours if kept clean and free of trash. They must perform properly in order to maintain consistent injection ratios. No regular maintenance is required if the system is

performing satisfactorily. When performance is in question and valves are suspect, they should be disassembled, cleaned thoroughly. Be certain to replace all parts as they were disassembled. ***It is absolutely necessary to install the valve with the arrow stamped on the side of the valve pointing in the direction of additive flow. Installing the valve backwards will prevent the pump from operating.***

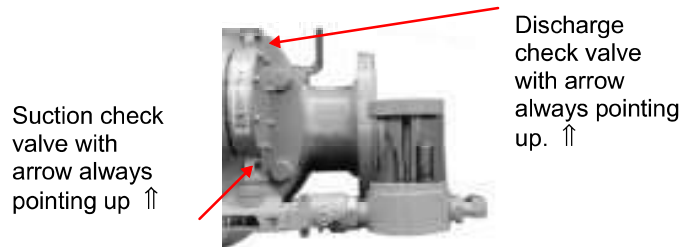

- The drive bearing located in the center of each injector pump is permanently lubricated and sealed. Again, depending on severity of service with respect to fuel flow rate and line pressure, these bearings will function for several years under daily use. Inspect the bearing by adjusting the stroke adjustment on each fluid end to zero. This will remove pressure contact from the bearing and allow the operator to feel the amount of “play” in the outer surface of the bearing. ***CAUTION Do not attempt to check the bearing when the system is operating. Doing so will mash your finger as the bearing rotates within the pump power frame.***
- Check and clean the screens in the Suction Sight Flow Indicators. These screens should be visually inspected daily and cleaned as necessary.

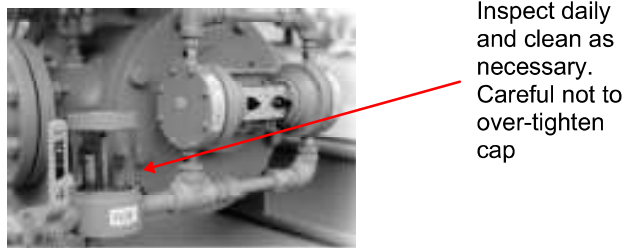

- Inspect all connections and tube fittings between tank and system. Inspect all pipe and tube fittings on injector for leaks. Remember: a leak on the suction side of the system (between the injector and tank) will cause problems.

.....***a few maintenance tips to remember***

- It is never convenient to repair an un-expected failure. Scheduled maintenance is faster, easier and cheaper to perform.
- This is a fluid handling system-----keep all the fluid connections tight.

ASSEMBLY AND DISASSEMBLY INSTRUCTIONS

PUMPS - DISASSEMBLY

The following instructions detail the dis-assembly and re-assembly of a complete system. Steps 1 - 4 detail the removal of the CI and SDA injectors. Beginning with Step 5, the FSII removal is detailed. To service the internals of either injector, review the section titled, "MAJOR INTERNAL PUMP SERVICE" that follows this section of the maintenance instructions.

Step 1 Disconnect the tubing on suction and discharge side of injector

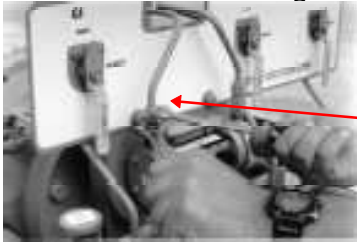

Be sure to use a backup wrench on all fittings. Do not loosen valve in fluid end.

STEP 2 Remove the adjustment locking screws and power frame cover

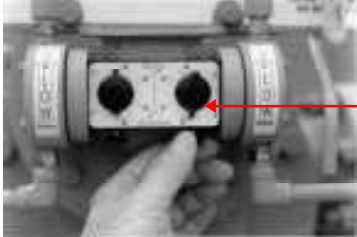

Mark your settings on the cover before removing knobs and cover

STEP 3 Remove the fluid end screws and fluid end

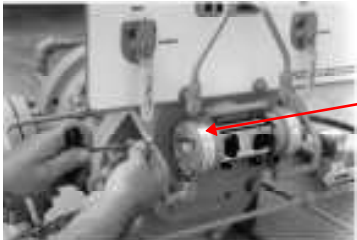

Use special instructions for removal and replacement of diaphragms later in manual

STEP 4 Refer to exploded view drawing below illustrating the CI and SDA pump internal parts. Go to step 5 for instructions on disassembly of the large dual fluid end FSII injector.

Step 5 Loosen tube fittings on suction and discharge on *one side only*.

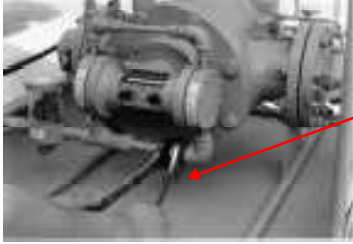

Be sure to back up all fittings with second wrench. Do not loosen fitting pipe threads

Step 6 For diaphragm service only, remove head screws



Remove head screws and head only if diaphragm service is required, otherwise it is not necessary to remove the head in order to remove the pump. Follow procedures in diaphragm service procedures carefully.

Step 7 Remove entire fluid end assembly



Step 8 Remove the diaphragm by rotating counter-clockwise.



Service Tip
Removing the diaphragm is easier if the stroke adjustment is first adjusted to zero. This extends the diaphragm so that it is easier to grasp. Be sure and mark the position on the dial before disturbing the setting. Loosen screw before moving cam.

Step 9 Remove the diaphragm and inspect for wear or delamination of the thin Teflon® layer and rubber backing.

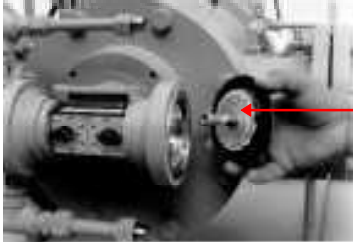

Check diaphragm for evidence of leakage, deterioration or distortion around outer edge. FSII will quickly dissolve the backing material. Also check tightness of fastener. Long service will sometimes pull the fastener out of the diaphragm.

Step 10 Loosen set screws in adjustment knobs and remove knobs and cover.

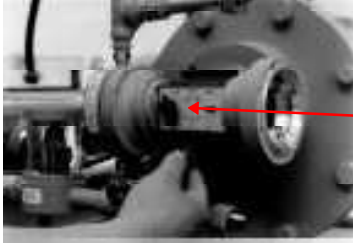

The CI & SDA adjustment knobs do not have set screws. They simply slip off. Use a small screw driver to pry the knobs off. The FSII knobs are secured with a small allen set screw.

Step 11 Remove the four screws holding the power frame to the fluid motor.

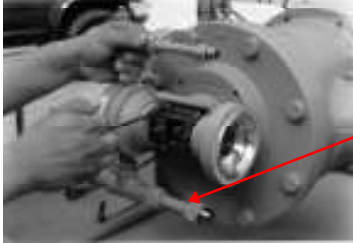

CAUTION
Additive may be trapped in the manifolding.

Step 12 Remove the snap ring retaining the eccentric drive bearing.



SERVICE TIP
The eccentric drive bearing will sometimes slip off the shaft when the pump is removed. Since it must be removed later, removing the snap ring may make pump removal easier.

Step 13 Remove the entire pump power frame.

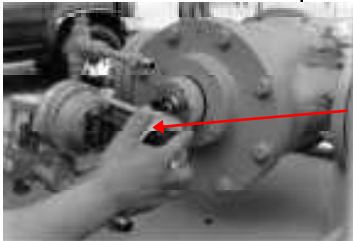

Do not force the power frame, the clearance is very close between parts.

Since the bearing is mounted off-center on the shaft, it will be necessary to move the pump power frame slightly in a circle to locate the center of the hole in the rear of the housing.

Step 14 Remove the bearing, bearing spacer and pump mounting block



SERVICE TIP
It is a good idea to lay these parts out in order as they are removed. Re-assembly can go much faster if you are sure of the order in which the system was disassembled.

Step 15 Remove the snap ring and flat spacer washer

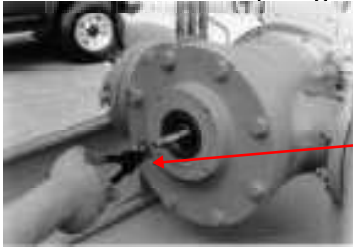

Use the correct size of snap ring pliers. Pliers that are too small can distort the ring.

Step 16 Remove the side plate bolts

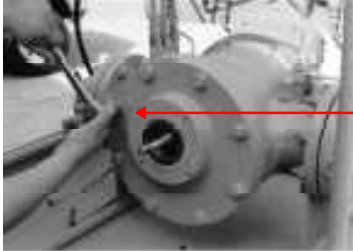

Remove bolts in a criss-cross pattern in order to reduce uneven stress on the side plate.

Step 17 **CAREFULLY** remove the side plate. Try not to drag plate on shaft.

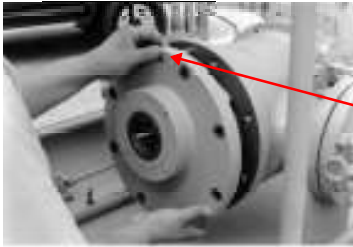

Support the side plate evenly with both hands. Note the alignment pin at the top of the housing.

Step 18 Examine the vane position and how they lay against the housing.



Notice the discharge vent in the housing in relationship to the vanes.

Step 19 Check each vane for freedom to fall against the housing. Check for excessive wear in the vane socket. If it appears that the vane could be pulled out of the socket, it should be replaced. Normally, vanes are replaced by the set, not individually and performance would be rough with one new vane and five worn ones remaining.



It is normal to see some wear in the center of the vane in the same position as the discharge vent of the housing. Vanes with considerable wear can be calibrated to perform at higher flow rates, but may not hold ratio at the lower flows. For some applications, this may be acceptable.

Step 20 **CAREFULLY** remove the seal bellows and carbon seal face.



Try not to touch the face of the carbon rotating member **DO NOT DROP THE CARBON SEAL.**

Step 21 Remove the brass wear ring.



There is a wear ring in each end of the rotor. Careful not to drop the other ring.

Step 22 Remove and inspect the rotor. Check for wear, breakage or looseness of vanes in their sockets. Check for wear of the anodized coating especially on each end. Worn coating indicates unlevel operation and or a worn brass wear ring in each end of the rotor recess.

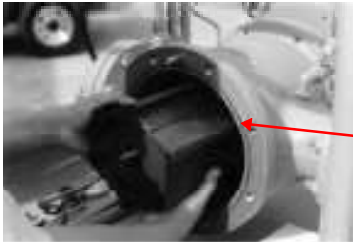

Use both hands to remove the rotor. The rotor weighs 28 pounds. Be careful!

CAUTION
The rotor has very thin vane sockets that bend and or break easily. Be very careful when sitting the rotor down not to damage these fragile ears.

Step 23 Examine both the shaft and housing.



Examine the housing carefully for scratches. Check the end plates also. The system will operate with some scratches in these surfaces, however, they may increase the wear rate of the vanes and reduce efficiency in the lower flow ranges of the system.

RE-ASSEMBLY OF THE FLUID MOTOR

From this point, the instructions will guide you through re-assembly. Follow each step carefully, paying particular attention to direction of flow and details of the mechanical seal.

Step 24 In preparation for re-assembly, be sure the two (2) drive keys are in place on the shaft. There is one on each end of the rotor shaft.

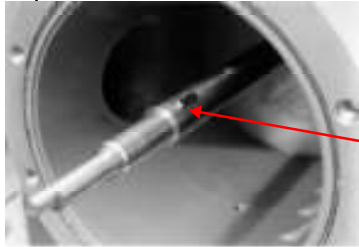

Be certain that both drive keys are fully pressed into their groove to accept rotor. A key that is raised only a few thousandths of an inch or one that has burrs will make re-installation of the rotor difficult if not impossible.

Step 25 Install the wear ring in the rear end of the rotor. To re-install the rotor, align the rear end of the rotor with the front drive key and gently slide the rotor all the way onto the shaft. Check the position of the visible drive key and re-install the remaining wear ring. Place a light film of grease on both sides of each wear ring before re-installing.

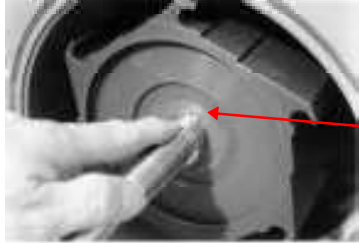

Be sure the key is in place and the rotor is all the way in. Check the proper direction of flow

CAUTION
Be absolutely sure that the rear brass wear ring has been installed and the direction of flow is correct. If the rotor is in backwards, it will not turn under flow.

Step 26 Re-install the vanes.

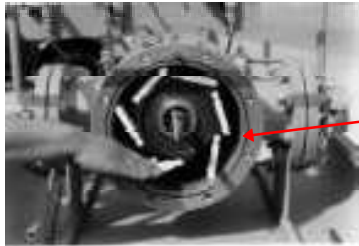

Make certain the rotor and vanes are installed as shown to trap the flow of fluid. **Be absolutely sure** the rotor is correct as indicated. If installed backwards, fuel will simply close the vanes and not turn the rotor. Match flow with arrow on housing.

Step 27 To re-install the mechanical seal, first examine the parts and understand the function of each part. Mechanical seals are very delicate. Be sure your hands are clean and you have a clean work area.

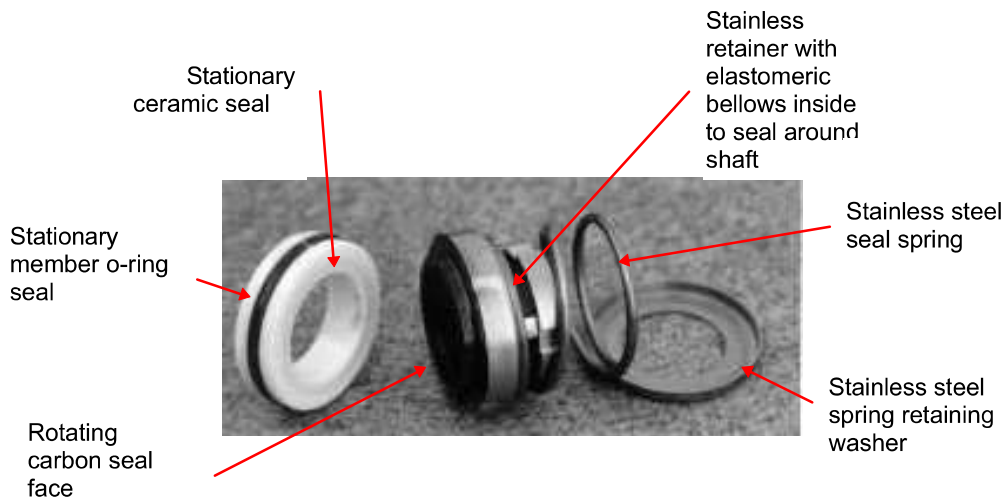

Note: Follow the next few steps to the letter. One piece of dirt or the smallest scratch can cause the seal to leak. Remember, there are two of these seals, one at each end of the main motor shaft located in each side plate.

Step 28 Apply a thin film of motor oil to the fluid motor shaft.

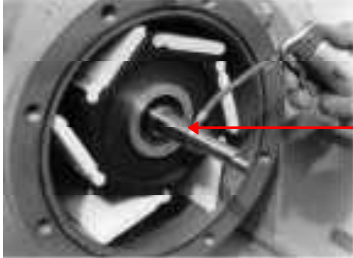

Use your fingers to distribute the oil around the entire exterior of the shaft.

Step 29 Install the Stainless steel washer, spring and bellows housing **only, do not install the rotating carbon seal yet.** Place it on a clean cloth for installation in the next step. Use both hands to slide the assembly on to the shaft all the way up next to the rotor.

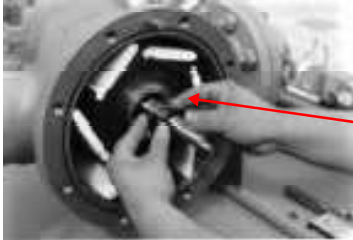

Install the pieces in this order...First the washer so that the lip retains the spring, then the spring, and finally the bellows housing *without the carbon seal.*

Step 30 Install the rotating carbon seal with small side out.



Now install the rotating carbon seal into the stainless bellows housing with the narrow or small surface facing out. **CAUTION** Try not to touch the face of the seal. The seal should fit recessed into the housing with the small indentions matching those dimples in the housing. If these do not match, and the seal is all the way into the housing, the seal will not only leak, but will be broken as soon as the side plate is re-installed. See figure at the top of the next page.

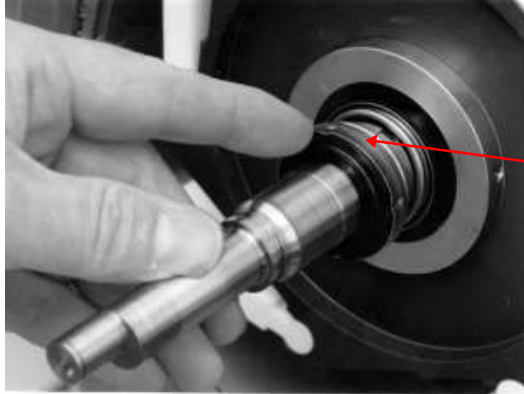

Be sure the small dimples match the indentions in the carbon seal

- Step 31 In preparation for installing the new ceramic seal in the motor side plate, remove the old ceramic seal out of the side plate pushing it out from the opposite side. The bearing will have to be removed first. You may be able to remove the bearing be simply using your finger through the bore of the bearing, carefully pulling it clear of the housing. Otherwise, use a non-metallic object to reach through the center of the seal on the opposite side and push the bearing clear of the housing. Now apply a film of oil to the external o-ring seal of the stationary ceramic seal. **Careful not to get oil on the seal face.**



Also apply a film of oil to the bore where the seal will be installed in the motor side plate. The oil will make insertion of the delicate ceramic seal easier. Install the shiny side facing up or to the inside of the housing just as the seal was packed from the factory.

- Step 32 Now gently lay the ceramic seal, shiny face up in the bore of the side plate, and lay the round cardboard protector shipped in the seal from the factory on the seal face. Using both thumbs, gently push the seal into place. Use even force, and rotate the force being sure it is all the way into the bore.



Using a clean, lint free cloth, wipe the surface of the ceramic seal, and examine the surface for any dirt or foreign material.

- Step 33 Re-install the o-ring in the housing face using a film of light grease to hold the o-ring in the groove.

- Step 34 Re-install the side plate, installing the bolts and tightening in a cross pattern. Remember, a leak free seal does not depend on tightness as

the o-ring is compressed when the side plate and the housing are mated face-to-face. Just snug the bolts until the lockwashers are compressed flat.

Step 35 Install the wave spring washer in the side plate bore.

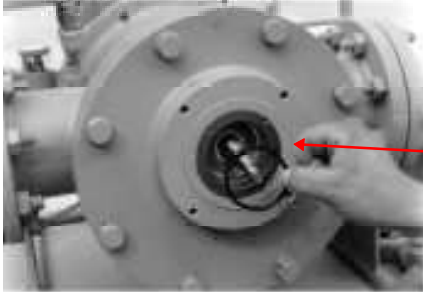

The wave washer is used on each end of the motor shaft to place tension on the shaft, and center the entire assembly between the two side plates. It is a very important part. Do not forget to install it.

Step 36 Install the bearing.



CAUTION - READ THIS FIRST BEFORE INSTALLING THE BEARING. Using very gentle, even force, to install the bearing. It will be necessary to pick up on the shaft somewhat since the weight of the rotor causes some deflection. Be careful not to attempt to push the bearing in one forceful push, this will cock the bearing and prevent any movement at all. Use very, very light touches all around the bearing at two points on opposite sides.

Step 37 Install the flat spacer washer and then the snap ring.

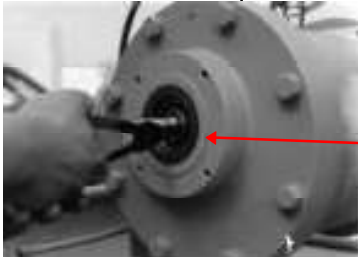

Don't forget the flat spacer washer!

Step 37 Complete the re-assembly by installing the pump mounting block, the pump and re-connecting all the fittings. Refer to the disassembly steps at the beginning of this section.

SO WHAT ABOUT THE OTHER SIDE PLATE, SEAL AND PUMP?

We have used the FSII side of the system to demonstrate the procedure. It could have been done from the other side. We suggest that **only one** side be disassembled at a time. If a seal is leaking, disassemble the side with the leak. Leave the other side in place. As you can see, the entire procedure can be performed from one side. It makes for a much easier re-assembly if the shaft and related parts are supported.

MAJOR INTERNAL PUMP SERVICE

PUMPS - REASSEMBLE (applies to either CI and SDA or FSII pumps)

Refer to this exploded view of the various internal parts of the pump. The power frame is the same for both the CI/SDA pump and the FSII pump. The larger FSII fluid ends and adapters are illustrated at the end of this section. Refer to the assembly drawings and parts lists to determine part numbers.

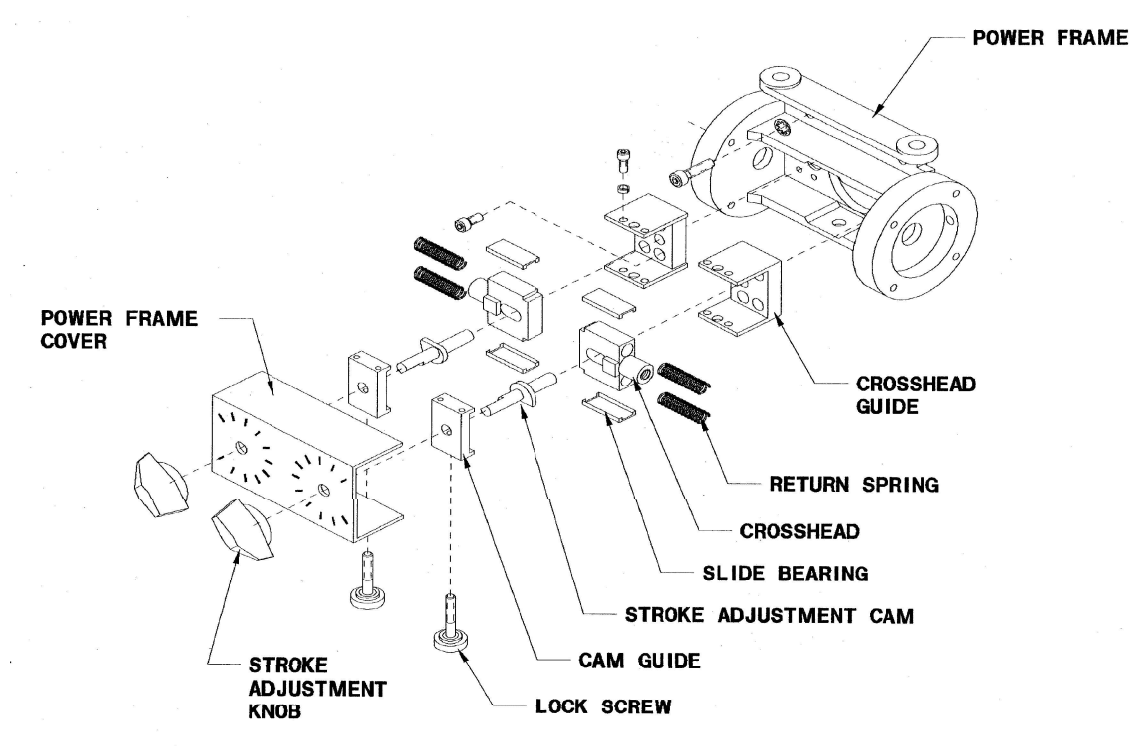

The following instructions detail the re-assembly of a basic power frame with internals. It is assumed that the exploded views provide sufficient instructions for disassembly.

Step 1 Install the crosshead guide.

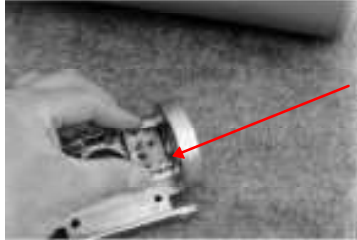

Install crosshead guide using 4 special screws with “spot lock” to hold screws tight.

CAUTION

On CI and SDA pumps, tighten snug. Do not over-tighten. On all stainless steel FSII pump internals, tighten crosshead screws to 50 inch pounds. Use a torque wrench on the FSII parts if at all possible.

Step 2 Install the plastic guides on each side of cross head.



Apply a small amount of grease on both sides of the plastic wear strip. The grease not only lubricates the wear strips, but acts as a cushion between the strip and crosshead.

Step 3 Apply grease liberally under the cross head and on each side and inside the walls of the crosshead guide, then place two springs in the holes on the end of the cross head. Install the guide into the cross head, with square boss on top and threaded nose pointing through the hole in the power frame.

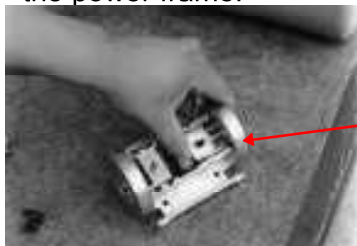

Use your thumb and forefinger to compress the return springs as you install the cam

Step 4 Install the cross head guide over the cam and install 4 screws.



Install special screws with lock patch on each screw. Tighten snugly.

Refer to the exploded views that follow for both CI/SDA and FSII injectors. They demonstrate the application of both small (for CI and SDA) and large (for FSII) fluid ends.

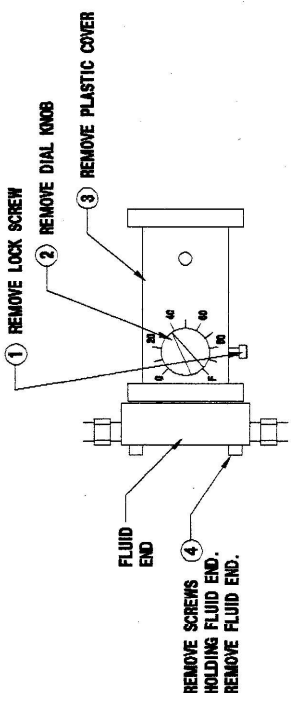

1

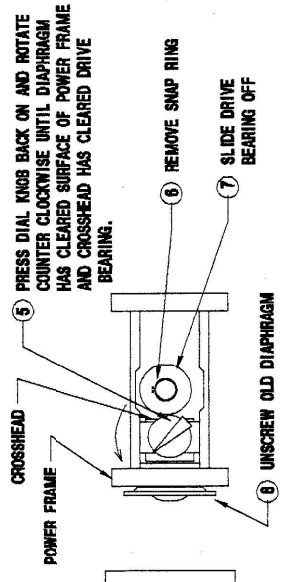

2

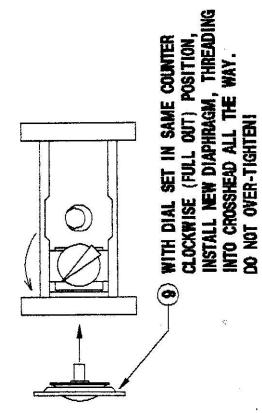

3

* WARNING... FAILURE TO TORQUE SCREWS PROPERLY TO 40 IN. LBS. WILL REDUCE PUMP HEAD PERFORMANCE, RESULTING IN INSUFFICIENT INJECTION RATIO.

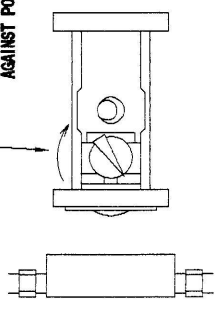

11 REINSTALL SCREWS, TAKING EACH ONE DOWN BY HAND UNTIL IT STOPS. TIGHTEN SCREWS TO 40 IN. LBS. * IN THE ORDER SHOWN BELOW. THEN TORQUE EACH SCREW IN THE PATTERN, THEN REPEAT THE TORQUE SEQUENCE ONLY ONCE!

4

WARNING! FAILURE TO FOLLOW THIS PROCEDURE WILL RESULT IN DIAPHRAGM DEFORMATION AND PREMATURE FAILURE.

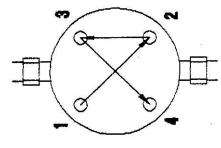

5

HAMMONDS TECHNICAL SERVICES, INC.

FOR TECHNICAL ASSISTANCE CALL
 HAMMONDS TECHNICAL SERVICES
 (281) 999-2900

SCALE NTS
 DATE 2/11/92
 DRAWING TITLE "S" DIAPHRAGM REPLACEMENT

APPROVED BY: S.S.
 REVISED 4/10/92

DRAWING NUMBER 1459

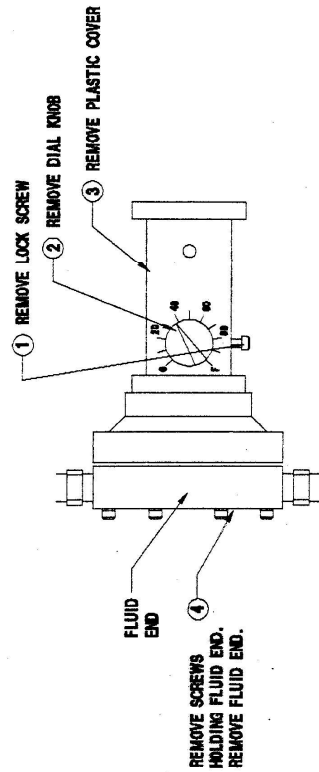

1

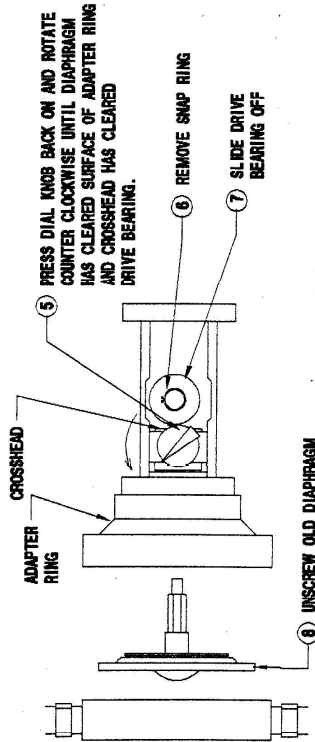

2

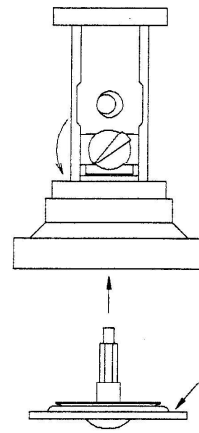

3

*** WARNING... FAILURE TO TORQUE SCREWS PROPERLY TO 40 IN. LBS. WILL REDUCE PUMP HEAD PERFORMANCE, RESULTING IN INSUFFICIENT INJECTION RATIO.**

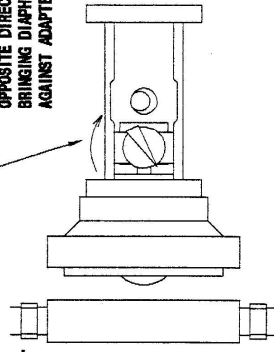

11 REINSTALL SCREWS, TAKING EACH ONE DOWN BY HAND UNTIL IT STOPS. TIGHTEN SCREWS TO 40 IN. LBS. * IN THE ORDER SHOWN BELOW. TORQUE EACH SCREW IN THE PATTERN, THEN REPEAT THE TORQUE SEQUENCE ONLY ONCE!

4

WARNING! FAILURE TO FOLLOW THIS PROCEDURE WILL RESULT IN DIAPHRAGM DEFORMATION AND PREMATURE FAILURE.

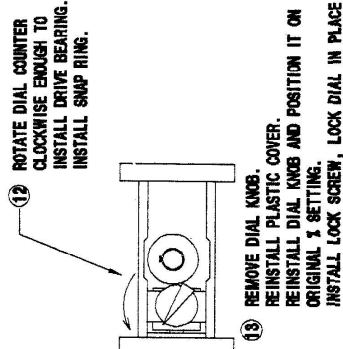
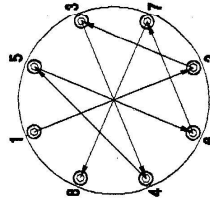

NOTE: AFTER THIS PROCEDURE IS COMPLETE, YOU MUST RECALIBRATE THE INJECTOR TO YOUR SPECIFICATIONS.

5

HAMMONDS TECHNICAL SERVICES, INC.

SCALE	NIS	APPROVED BY:	S.S.
DATE	2/17/92	REVISED	
DRAWING TITLE		"L" DIAPHRAGM REPLACEMENT	
(FSII)		DRAWING NUMBER 1461	

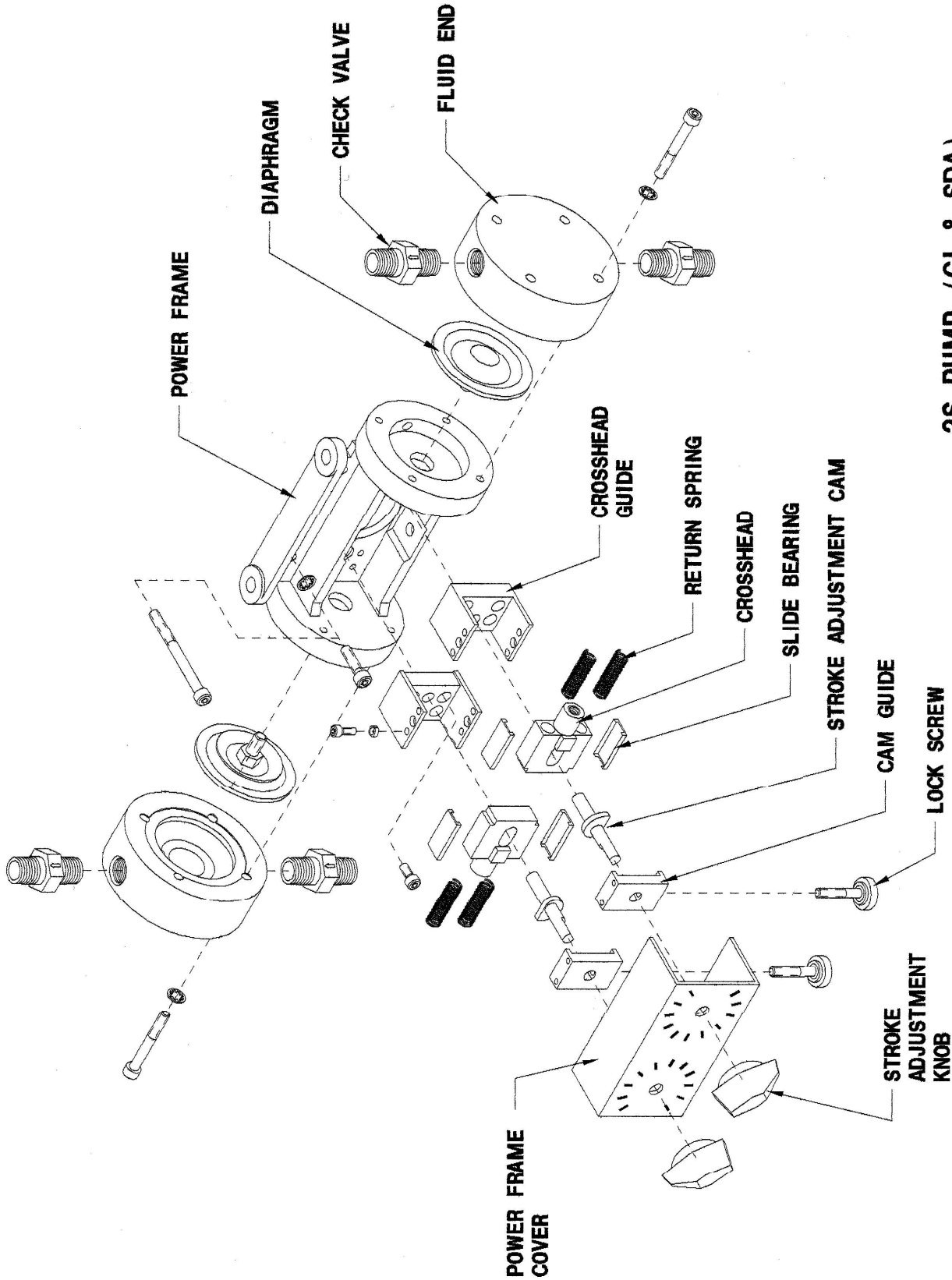

2S PUMP (CI & SDA)

ITEM	PART NO.	QTY.	DESCRIPTION
1	101014	1	POWER FRAME
2	101016	2	DIAPHRAGM, S
2A	101455	2	DIAPHRAGM, S, VITON (OPTION)
3	102001	2	FLUID END, S
4	882949	12	LOCK WASHER, #10
5	101037	8	SCREW, 10-32 x 1 1/2"
6	101008	2	CROSSHEAD GUIDE
7	101007	4	RETURN SPRING
8	101006	2	CROSSHEAD
9	101152	4	SLIDE BEARING
10	101005	2	STROKE ADJUSTMENT CAM
11	101003	2	CAM GUIDE
12	101001	2	STROKE ADJUSTMENT KNOB
13	101002	1	POWER FRAME COVER
14	101004	2	LOCK SCREW
15	101009	8	SCREW, 8-32 x 3/8"
16	881086	8	LOCKWASHER, #6
17	101010	8	SCREW, 6-32 x 3/8"
18	881089	4	SCREW, 10-32 x 3/4"
18A	881560	4	SCREW, 10-32 x 2 1/4" (OPT)
20	102263	4	CHECK VALVE

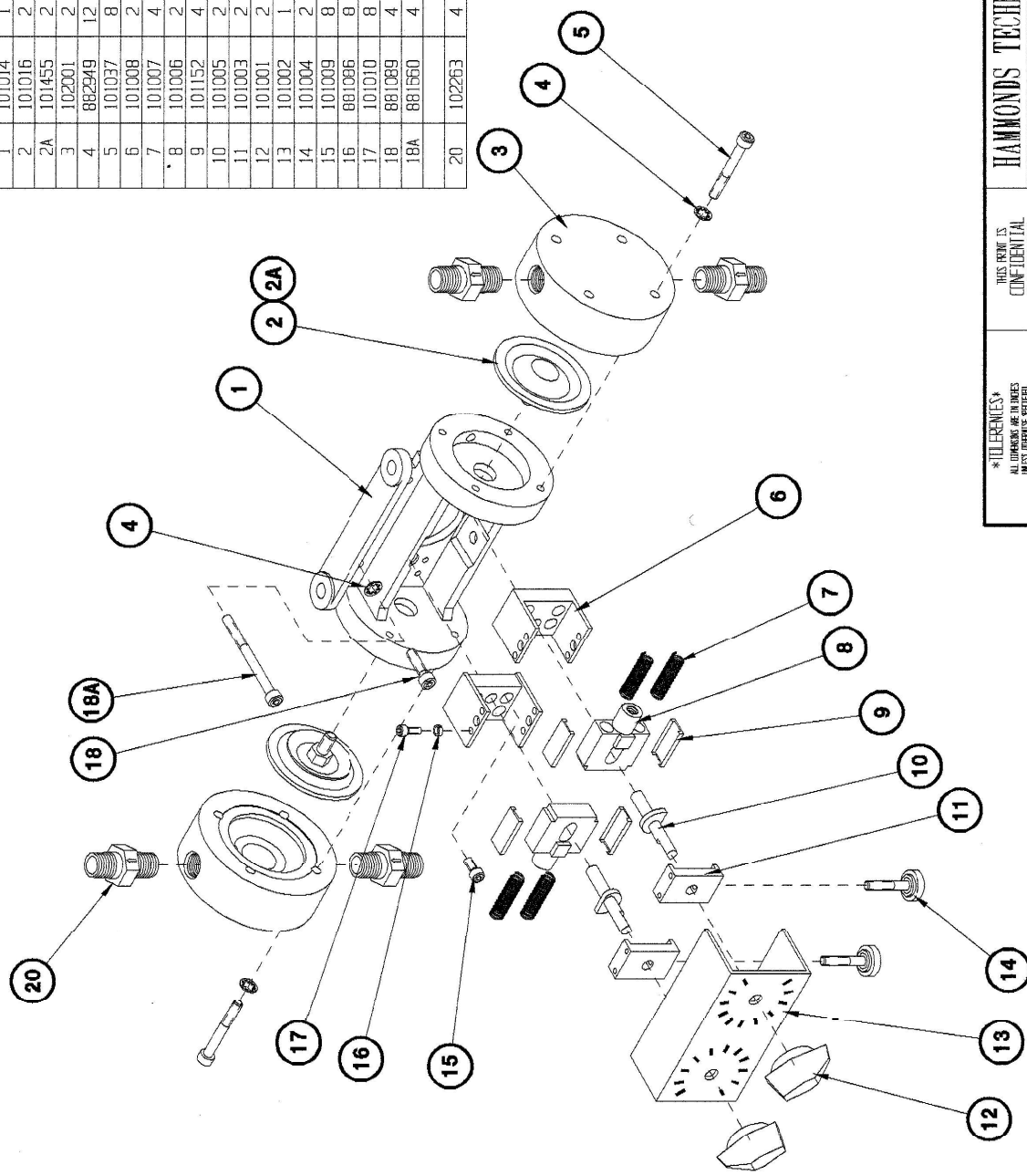

HAMMONDS TECHNICAL SERVICES, INC.

SCALE: NTS APPROVED BY: SS
 DATE: 10/15/95
 DRAWING TITLE: HAMMONDS 2S PUMP (CI & SDA)
 DRAWING NUMBER: 1170

THIS DRAWING IS CONFIDENTIAL AND IS THE PROPERTY OF HAMMONDS TECHNICAL SERVICES.
 THIS PUMP SHALL NOT BE USED, COPIED OR REPRODUCED IN ANY MANNER IN ANY MEDIUM WITHOUT PERMISSION OF HAMMONDS TECHNICAL SERVICES.

TOLERANCES
 ALL DIMENSIONS ARE IN INCHES UNLESS OTHERWISE SPECIFIED.

*TOL. DECIMALS: *TOL. ANGLES:
 .XX = .005 ° = .5 DEGREES
 .XX = .015 ° = .5 DEGREES
 .X = .030 ° = 1.0 DEGREES

Ø / REMOVE DIMS AND BREAK EDGES, 30° MIN.

DRAWING	LEVELS	VIEW
INJECTOR	8-20, 23, 24, 27, 28, 30-41, 45	7
FROM SER#	TO SER#	DATE
X	X	X

NO.	REVISION	DATE	BY
X			

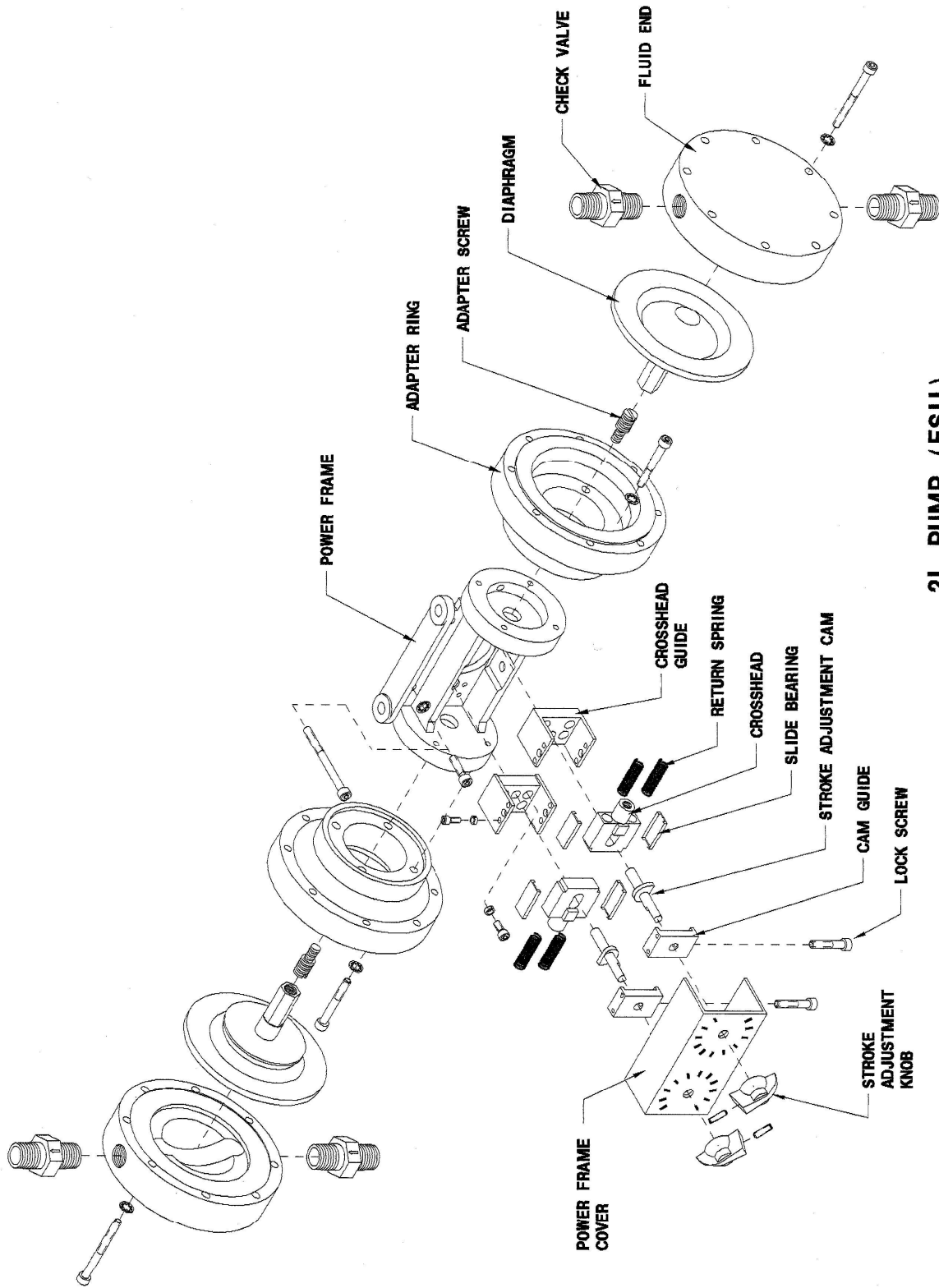

2L PUMP (FS11)

ITEM	PART NO.	QTY.	DESCRIPTION
1	184038	1	HOUSING, ALUMINUM
2	184040	1	ROTOR
3	184081	1	SHAFT, ER (SINGLE ECC.)
4	184093	2	END PLATE
5	141036	2	MECHANICAL SEAL
6	103363	2	WAVE SPRING WASHER
7	881823	2	BEARING
8	184004	2	THRUST WASHER
9	103361	2	SNAP RING
10	103409	2	O-RING, VITON
11	881821	16	BOLT, 5/8-11 x 2"
12	882076	16	LOCK WASHER, 5/8"
13	182002	2	WEAR RING
14		2	KEY, 15/64 SQ. x 1"
15	184011	6	VANE, TEFLON
16	151006	1	PLUG
17	184037	1	BEARING CAP
18	881882	1	BEARING
19	881999	1	SPACER
20	881157	1	H.D. DRIVE BEARING
21	101045	1	SNAP RING

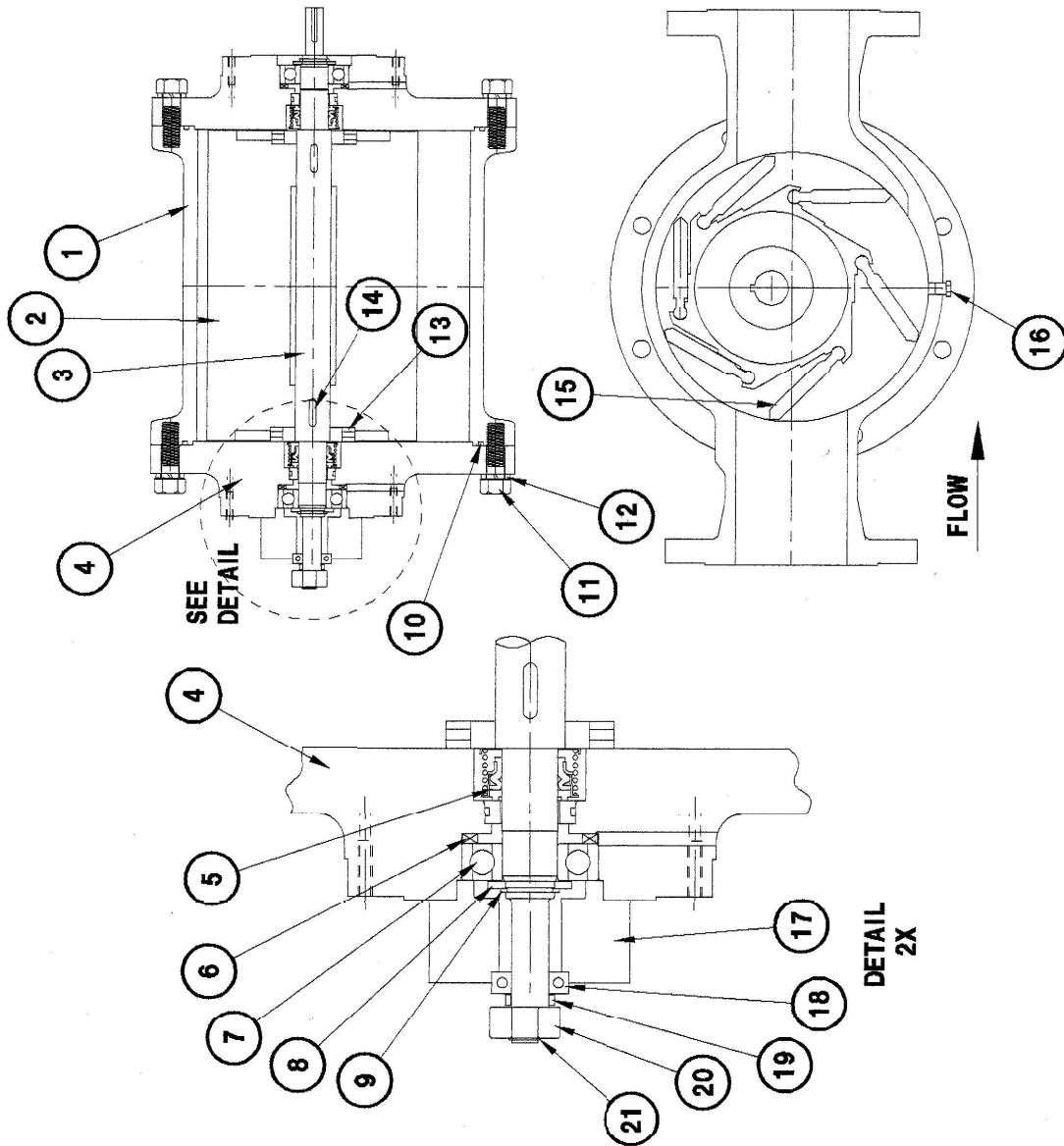

TOLERANCES ALL DIMENSIONS ARE IN INCHES UNLESS OTHERWISE SPECIFIED.		THIS DRAWING IS CONFIDENTIAL AND IS THE PROPERTY OF HAMMONDS TECHNICAL SERVICES IT IS NOT TO BE REPRODUCED OR TRANSMITTED IN ANY FORM OR BY ANY MEANS, ELECTRONIC OR MECHANICAL, INCLUDING PHOTOCOPYING, RECORDING, OR BY ANY INFORMATION STORAGE AND RETRIEVAL SYSTEM, WITHOUT THE WRITTEN PERMISSION OF HAMMONDS TECHNICAL SERVICES.	
SCALE: NTS	DATE: 08/27/96	APPROVED BY:	DRAWN BY: SS
REVISED:			
DRAWING TITLE: MODEL 800ER DRIVER (ALUM.)		DRAWING NUMBER: 2963	
DRAWING: 8000RWR	LEVELS: 228, 229	VIEW: 1	
FROM: SER#	DATE	TO: SER#	DATE
X	X	X	X
NO. REVISION	DATE	BY	

ITEM	PART NO.	QTY.	DESCRIPTION
1	184047	1	ADAPTER PLATE
2	184048	1	GEAR HOUSING
3	881673	2	SET SCREW
4	1	1	KEY, 1/8" SQ. x 5/8"
5	881083	8	LOCKWASHER
6	881318	4	BOLT
7	881120	3	BEARING
8	881119	2	SNAP RING
9	881680	1	SPACER
10	881157	1	BEARING, H.D. DRIVE
11	101045	1	SNAP RING
12	212048	1	OUTPUT SHAFT
13	881024	1	SEAL
14	190012	1	GEAR, 120 TOOTH
15	190011	1	KEY, 3/16" SQ. x 23/32"
16	881670	1	SPACER
17	881084	4	BOLT
18	881084	4	BOLT
19	881521	1	GREASE FITTING

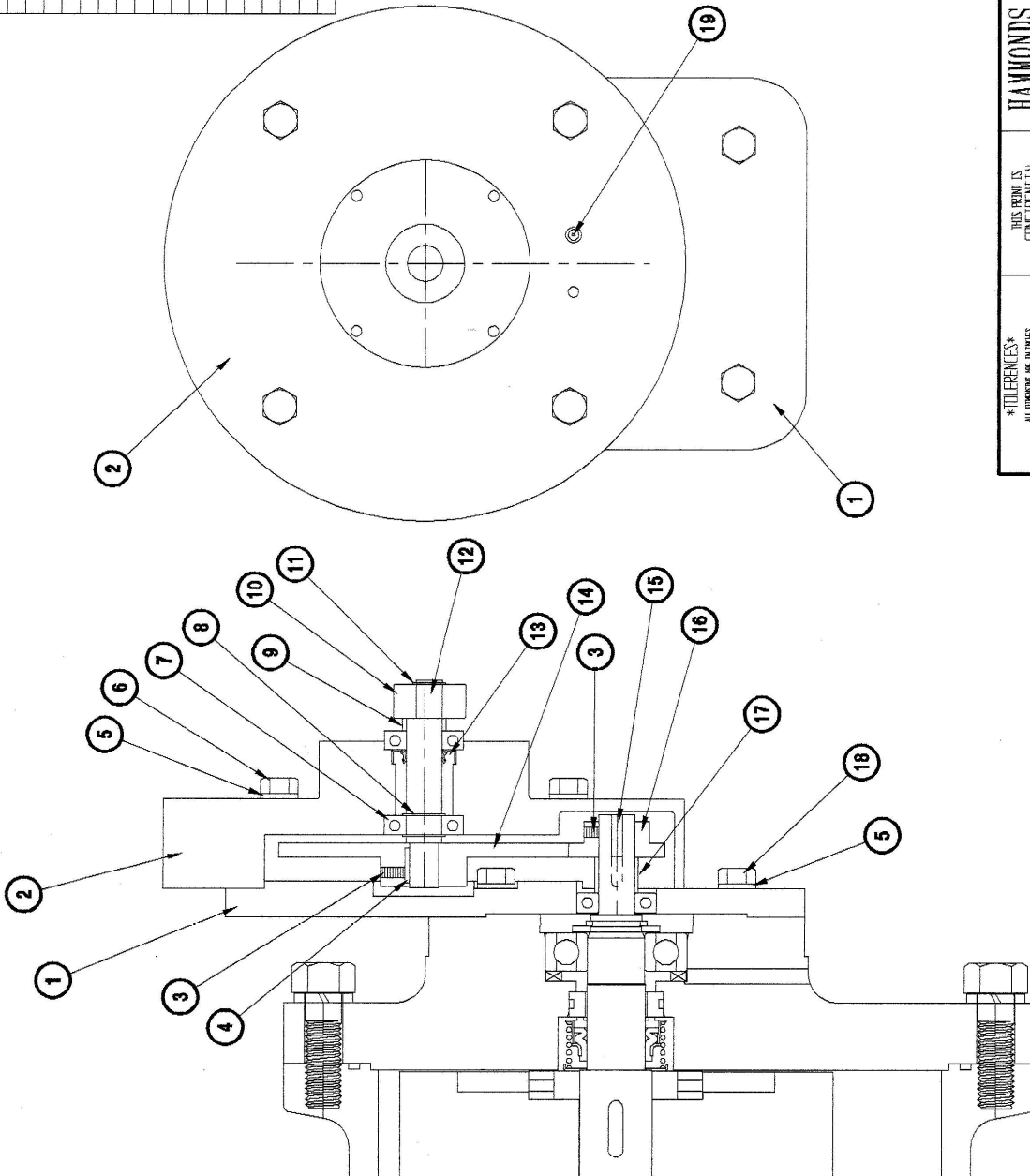

HAMMONDS TECHNICAL SERVICES, INC.

SCALE: NTS
DATE: 08/20/52
DRAWING TITLE: MODEL 800 GEAR REDUCER
APPROVED BY: [Signature]
DRAWN BY: SS
REVIEWED: [Signature]

GEAR RATIO = 3:1

DRAWING NUMBER: **1694**

THIS DRAWING IS CONFIDENTIAL AND IS THE PROPERTY OF HAMMONDS TECHNICAL SERVICES. THIS DRAWING SHALL NOT BE USED, COPIED OR REPRODUCED IN WHOLE OR IN PART WITHOUT THE WRITTEN PERMISSION OF HAMMONDS TECHNICAL SERVICES.

TOLERANCES
ALL DIMENSIONS ARE IN INCHES UNLESS OTHERWISE SPECIFIED.

*TITL. DECIMALS: .XX = 1/2 - .005
 .XX = 1/2 - .015
 .X = 1/2 - .030

*TITL. ANGLES: 1/2 - 5 DEGREES
 1/2 - 5 DEGREES

*CONCENTRICITY: .005 T.I.R.
 1/2 - .030

*REMOVE BURRS AND BREAK EDGES .005 MIN.

NO.	REVISION	DATE	BY	LEVELS	VIEW
X				230, 231	I
X					
X					
X					

ITEM	PART NO.	QTY.	DESCRIPTION
1	883085	1	FRAME ASSEMBLY
2	102169	1	TOP PANEL
3	102170	2	SIDE PANEL
4	102168	1	SKID PAN
5	162018	4	SAFETY PIN
6	102284	1	VALVE PANEL
7	101701	1	DECAL KIT
8	102285	3	VALVE POINTER
9	101180	3	3-WAY VALVE
10	101068	4	3/8 x 1/4 MNPT EL TUBE ADPT.
11	271112	3	1/2 x 1/4 REDUCING BUSHING
12	101284	7	3/8 x 1/2 MNPT TUBE ADAPTER
13	101230	3	ON/OFF VALVE 1/4"
14	271125	3	1/4" 90 ST. EL
15	271113	2	3/4 x 1/4 REDUCING BUSHING
16	101070	1	1/4 x 1 1/2 NIPPLE
17	101032	1	1/4" CROSS
18	101671	3	CHECK VALVE, SOFT SEAT

ITEM	PART NO.	QTY.	DESCRIPTION
* 37	101693	1	3/8 LINE, SDA 3-WAY/INJ. CV
* 38	101689	1	3/8 LINE, CI PUMP/3-WAY
* 39	101690	1	3/8 LINE, SDA PUMP/3-WAY
* 40	101695	1	3/8 LINE, PRIME VLV./CI SFI
* 41	101696	1	3/8 LINE, CI SFI/SDA SFI
* 42	101697	1	3/8 LINE, SDA SFI/FSII SFI
43	101034	8	3/8 x 1/4 MNPT TUBE ADAPTER
44	101023	2	1/4 TEE
45	101054	3	1/4 CHECK VALVE
46	101091	1	3/8 x 1/4 FNPT EL TUBE ADPT.
47	101069	2	1/4 x CL. NIPPLE
48	271084	2	1/4 x 3 NIPPLE
49	101021	2	1/4 90 ELBOW
* 50	101700	2	3/8 FLEX LINE ASS'Y. CI/SDA
* 51	101699	1	3/4 FLEX LINE ASS'Y. FSII
52	881725	1	4" DUST PLUG
53	881724	1	4" FEMALE CAMLOK W/4" FNPT
54	881740	2	4" x CL. NIPPLE

ITEM	PART NO.	QTY.	DESCRIPTION
19	101088	5	3/8 x 1/4 FNPT TUBE ADAPTER
20	271262	2	3/4 x 3/8 REDUCING BUSHING
21	271123	1	3/4 90 ELBOW
22	101128	4	3/4 x 3/4 MNPT TUBE ADAPTER
* 23	101686	1	3/4 SUCTION TUBE ASS'Y. FSII
24	271131	1	3/4 TEE
25	271096	1	3/4 x 3" NIPPLE
26	271094	1	3/4 x CL. NIPPLE
27	101205	1	3/4 ON/OFF VALVE
28	271127	1	3/4 90 ST. EL
29	271115	2	1/2 x 3/8 REDUCING BUSHING
30	271130	1	1/2 TEE
31	101141	2	1/2 x 1/2 MNPT TUBE ADAPTER
* 32	101687	1	1/2 DISCHARGE TUBE ASS'Y FSII
33	271122	1	1/2 90 ELBOW
* 34	101688	1	3/8 LINE, FSII PUMP/3-WAY
* 35	101691	1	3/8 LINE, FSII 3-WAY/INJ. CV
* 36	101692	1	3/8 LINE, CI 3-WAY/INJ. CV

ITEM	PART NO.	QTY.	DESCRIPTION
55	881722	1	4" MALE CAMLOK W/ 4" FNPT
56	881260	1	4" DUST CAP
57	271498	2	4" 150# COMP. FLANGE 4"NPT
58	161001	2	4" GASKET
59	881249	16	5/8-11 x 4 STUD W/NUTS
60	103028	8	1/4 FLAT WASHER SS
61	881259	8	1/4 LOCK WASHER SS
62	103027	8	1/4-20 x 3/4 HEX BOLT SS
63	882949	6	#10 LK. WSHR, INT. TOOTH SS
64	881645	6	#10-24 x 3/8 SOC.HD. CAP SS
* 65	101694	3	3/8 CALIB. TUBE/FSII/CI/SDA
66	101702	1	INSTRUCTION LABEL
67	881356	3	PRIMING BULB
*	101698	1	TUBE SET COMPLETE FOR 4T-4A

* INCLUDES ALL TUBE ASS'Y. WITH * BY ITEM NO.

DRAWING		LEVELS		VIEW	
1839-a		4, 7, 8, 11-19, 23, 24, 30-36		1	
NO.	REVISION	DATE	BY	DATE	BY
	X	X	X	X	X

<p>*TOLERANCES*</p> <p>ALL DIMENSIONS ARE IN INCHES UNLESS OTHERWISE SPECIFIED.</p>		<p>THIS PRINT IS CONFIDENTIAL AND IS THE PROPERTY OF HAMMONDS TECHNICAL SERVICES</p> <p>THIS PRINT SHALL NOT BE USED, COPIED OR REPRODUCED IN WHOLE OR IN PART NOR SHALL THE CONTENTS BE REVEALED IN ANY MANNER TO ANYONE UNLESS WRITTEN PERMISSION IS OBTAINED FROM HAMMONDS TECHNICAL SERVICES.</p>		<p>HAMMONDS TECHNICAL SERVICES, INC.</p>	
<p>*TOL. DECIMALS:</p> <p>.XXX= +/- .005</p> <p>.XX= +/- .015</p> <p>.X= +/- .030</p>	<p>*TOL. ANGLES:</p> <p>+/- .5 DEGREES</p>	<p>*CONCENTRICITY:</p> <p>.005 T.I.R.</p>	<p>*REMOVE BURRS AND BREAK EDGES .005 MIN.</p>	<p>SCALE NTS</p> <p>DATE 10/15/96</p> <p>DRAWING TITLE</p>	<p>APPROVED BY:</p> <p>DRAWN BY SS</p> <p>REVISED</p>
<p>HAMMONDS MODEL 4T-4A</p>				<p>DRAWING NUMBER 1839</p>	

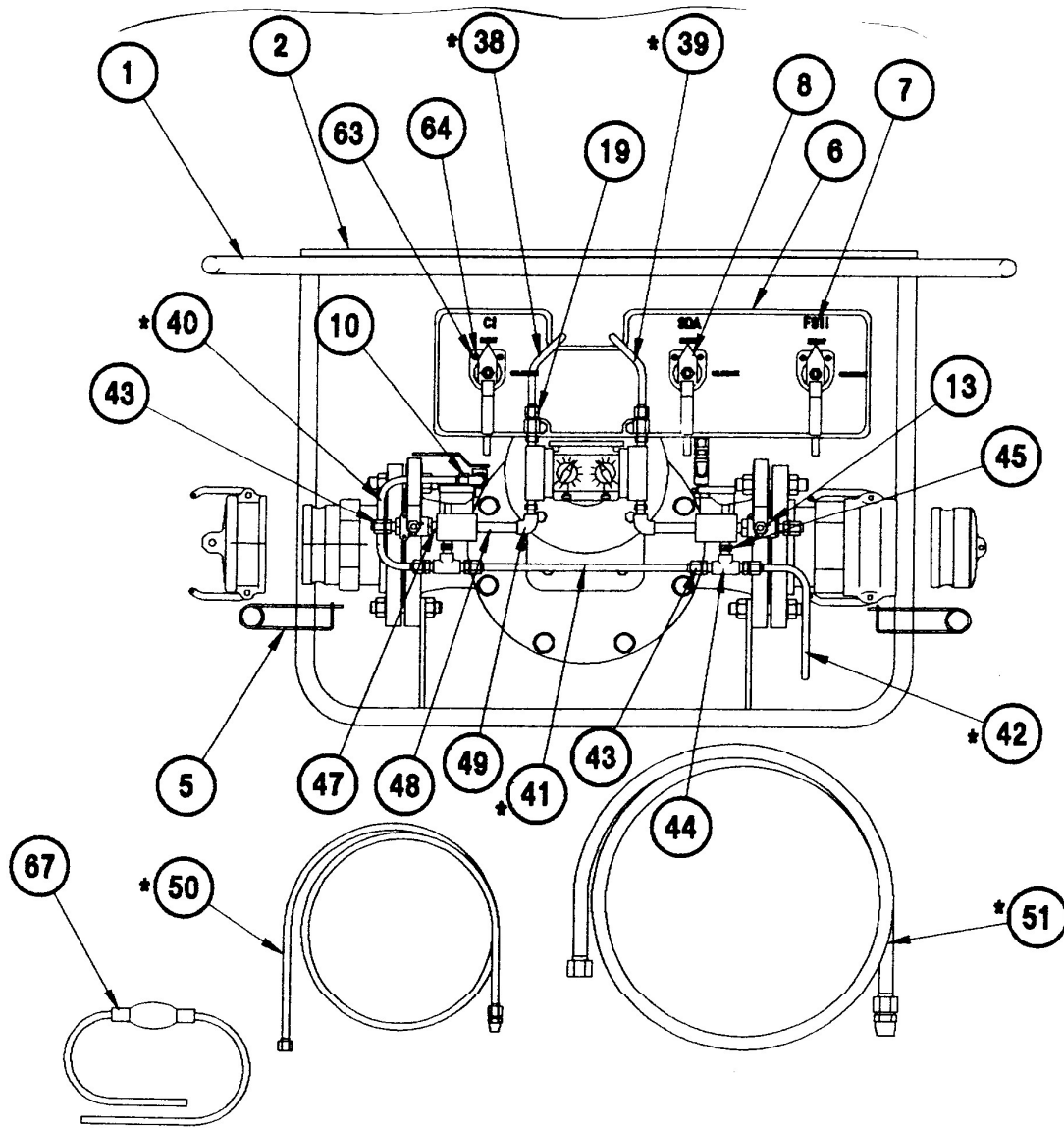

DRAWING	LEVELS	VIEW
1839-B	4, 7, 8, 11-19, 23, 24, 30-36	1

X	X	X	X	FROM SER#	DATE	TO SER#	DATE
NO.	REVISION	DATE	BY	X	X	X	X

TOLERANCES
ALL DIMENSIONS ARE IN INCHES UNLESS OTHERWISE SPECIFIED.

*TOL. DECIMALS: .XXX= +/- .005 .XX= +/- .015 .X= +/- .030	*TOL. ANGLES: +/- .5 DEGREES
*CONCENTRICITY: .005 T.I.R.	

125
*REMOVE BURRS AND BREAK EDGES .005 MIN.

THIS PRINT IS CONFIDENTIAL AND IS THE PROPERTY OF HAMMONDS TECHNICAL SERVICES

THIS PRINT SHALL NOT BE USED, COPIED OR REPRODUCED IN WHOLE OR IN PART NOR SHALL THE COMMENTS BE REVEALED IN ANY MANNER TO ANYONE UNLESS WRITTEN PERMISSION IS OBTAINED FROM HAMMONDS TECHNICAL SERVICES.

HAMMONDS TECHNICAL SERVICES, INC.

SCALE	NTS	APPROVED BY:	DRAWN BY	SS
DATE	10/15/96		REVISED	

DRAWING TITLE: **HAMMONDS MODEL 4T-4A**

DRAWING NUMBER: **1839**

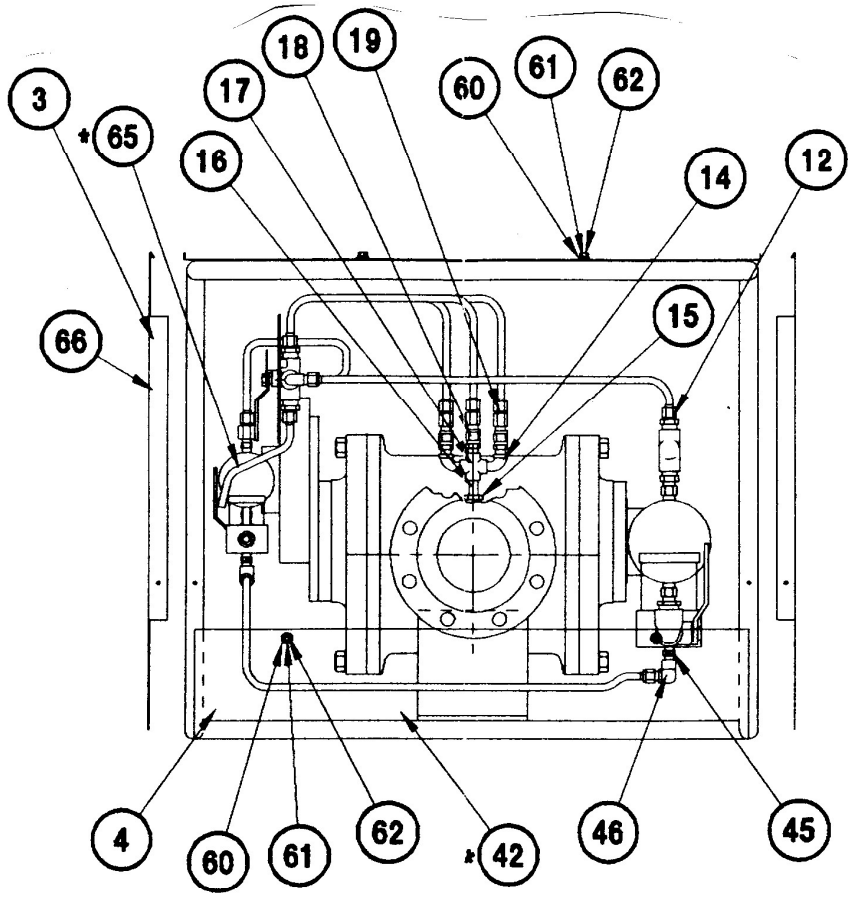

DRAWING		LEVELS		VIEW
1839 - C		4, 7, 8, 11-19, 23, 24, 30-36		1
NO.	REVISION	DATE	BY	DATE
X	X	X	X	X
FROM SER#	DATE	TO SER#	DATE	
X	X	X	X	

<p>*TOLERANCES* ALL DIMENSIONS ARE IN INCHES UNLESS OTHERWISE SPECIFIED.</p> <p>*TOL. DECIMALS: .XXX = +/- .005 .XX = +/- .015 .X = +/- .030</p> <p>*TOL. ANGLES: +/- .5 DEGREES</p> <p>*CONCENTRICITY: .005 T.I.R.</p> <p>*REMOVE BURRS AND BREAK EDGES .005 MIN.</p>		<p>THIS PRINT IS CONFIDENTIAL AND IS THE PROPERTY OF HAMMONDS TECHNICAL SERVICES</p> <p>THIS PRINT SHALL NOT BE USED, COPIED OR REPRODUCED IN WHOLE OR IN PART NOR SHALL THE CONTENTS BE REVEALED IN ANY MANNER TO ANYONE UNLESS WRITTEN PERMISSION IS OBTAINED FROM HAMMONDS TECHNICAL SERVICES.</p>	<p>HAMMONDS TECHNICAL SERVICES, INC.</p> <p>SCALE: NTS DATE: 10/15/96</p> <p>APPROVED BY: _____</p> <p>DRAWING TITLE: HAMMONDS MODEL 4T-4A</p>	<p>DRAWN BY: SS REVISED:</p> <p>DRAWING NUMBER: 1839</p>
---	--	---	--	---

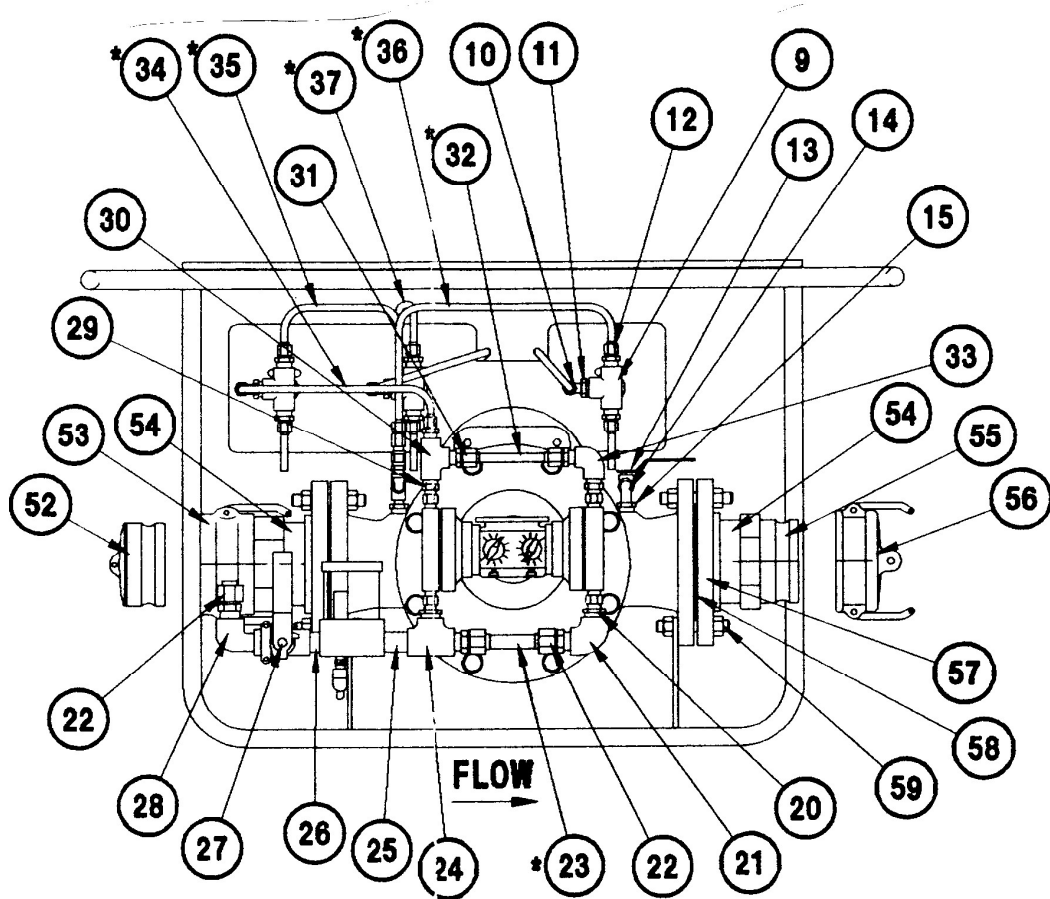

DRAWING	LEVELS	VIEW
1839-D	4,7,8,11-19,23,24,30-36	1

NO.	REVISION	DATE	BY	FROM SER#	DATE	TO SER#	DATE
	X	X	X	X	X	X	X

TOLERANCES
ALL DIMENSIONS ARE IN INCHES UNLESS OTHERWISE SPECIFIED.

*TOL. DECIMALS: .XXX= +/- .005 .XX= +/- .015 .X= +/- .030	*TOL. ANGLES: +/- .5 DEGREES
*CONCENTRICITY: .005 T.I.R.	

125
SURFACE FINISH
✓

*REMOVE BURRS AND BREAK EDGES .005 MIN.

THIS PRINT IS CONFIDENTIAL AND IS THE PROPERTY OF HAMMONDS TECHNICAL SERVICES

THIS PRINT SHALL NOT BE USED, COPIED OR REPRODUCED IN WHOLE OR IN PART NOR SHALL THE CONTENTS BE REVEALED IN ANY MANNER TO ANYONE UNLESS WRITTEN PERMISSION IS OBTAINED FROM HAMMONDS TECHNICAL SERVICES.

HAMMONDS TECHNICAL SERVICES, INC.			
SCALE	NTS	APPROVED BY:	DRAWN BY SS
DATE	10/15/96		REVISED
DRAWING TITLE		HAMMONDS MODEL 4T-4A	
			DRAWING NUMBER 1839

INSTALL CAP HAND-TIGHT...
DO NOT OVER-TIGHTEN!

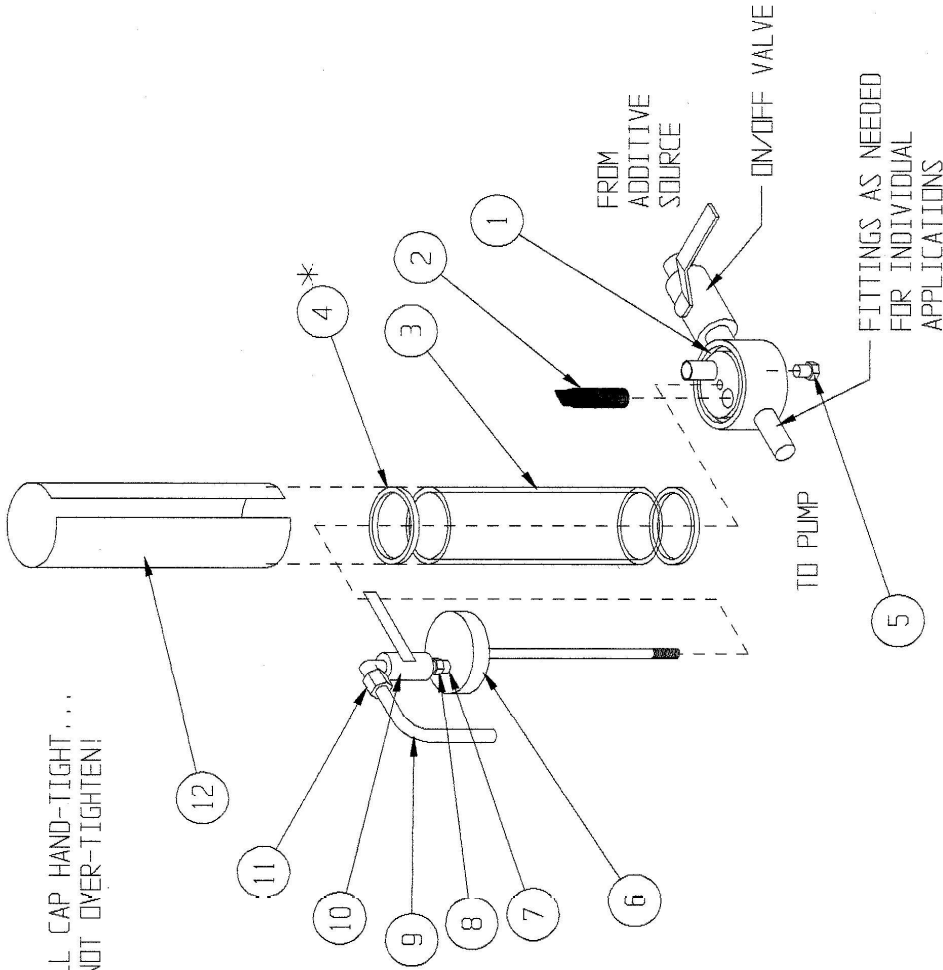

ITEM	PART NO.	QTY.	DESCRIPTION
1	152018	1	BODY, STD. SIGHT FLOW
2	152002	1	FILTER ELEMENT
3	151018	1	GALIGE GLASS
*4	151002	2	GASKET, BUINA
5	151005	1	PLUG
6	152069	1	CAP ASSEMBLY
7	881679	1	NIPPLE, 1/8" X CLOSE
8	271385	1	RED. BUSHING, 1/4X 1/8
9	101059	1	TUBING, 1/4" X .035"
10	101230	1	ON/OFF VALVE, 1/4"
11	101071	1	ELBOW TUBE FITTING
12	152070	1	GUARD, GAUGE GLASS
*4	151007	2	GASKET, VITON
			OPTIONAL

THIS DRAWING IS CONFIDENTIAL AND THE PROPERTY OF HAMMONDS TECHNICAL SERVICES, INC. THIS DRAWING IS TO BE USED ONLY FOR THE PURPOSES SPECIFIED HEREIN. ANY REPRODUCTION OR USE OF THIS DRAWING FOR ANY OTHER PURPOSE IS STRICTLY PROHIBITED. HAMMONDS TECHNICAL SERVICES, INC.

SCALE: NTS
DATE: 07/20/93
DRAWING TITLE: SUCTION CALIBRATION GAUGE
DRAWN BY: SCG206
REVISED BY: SS

MAT'L: 3067

TOLERANCES
ALL DIMENSIONS ARE IN INCHES UNLESS OTHERWISE SPECIFIED.

*TOL. DECIMALS: *TOL. ANGLES:
 .XX = +/- .005 +/- .5 DEGREES
 .XXX = +/- .015 *UNLESS OTHERWISE SPECIFIED
 .X = +/- .030 .005 T.I.R.

125/1000
REMOVE BURRS AND BREAK EDGES .005 MIN.

DRAWING	REV.	DATE	DATE	DATE
2489	5,6			

NO.	REVISION	DATE	BY
X			

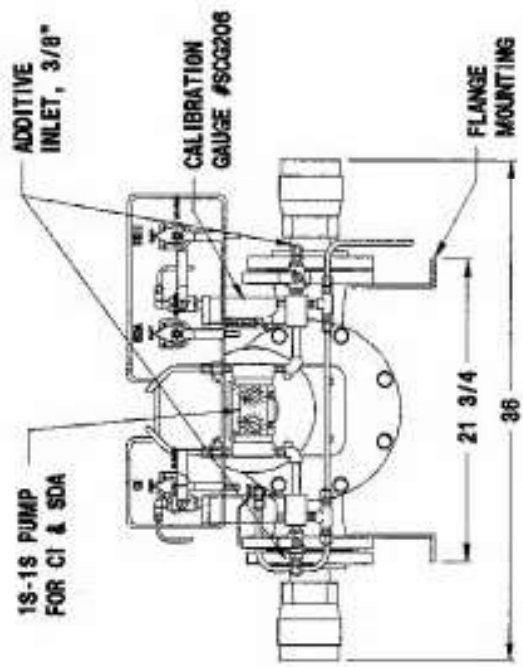

BACK VIEW

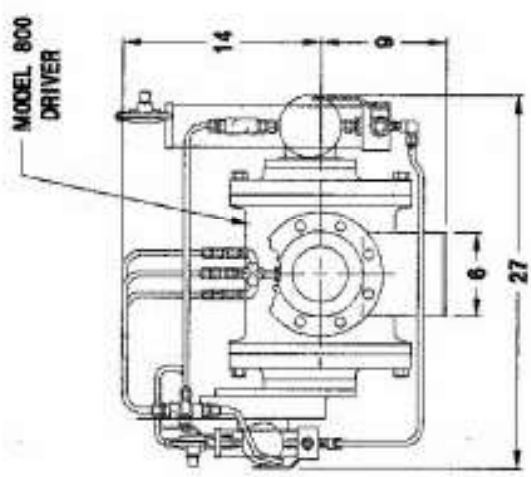

INLET VIEW

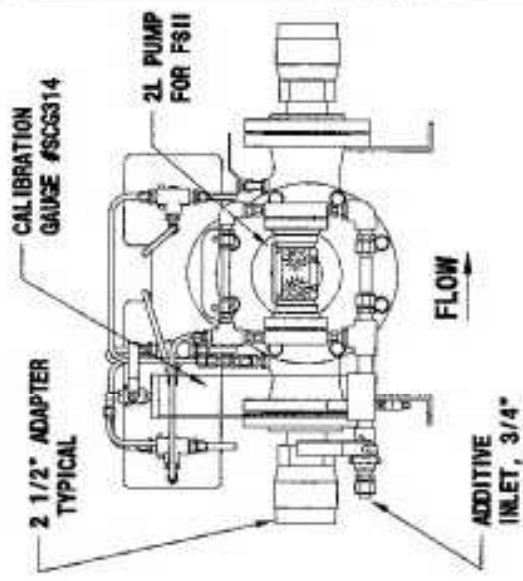

FRONT VIEW

TOLERANCES ALL DIMENSIONS IN INCHES UNLESS OTHERWISE SPECIFIED *FRACTIONS* DECIMALS: *REL. ANGLES: 1/16, 1/8, 3/16, 1/4, 3/8, 1/2, 5/8, 3/4, 7/8, 1, 1 1/8, 1 1/4, 1 1/2, 1 3/4, 1 7/8, 2, 2 1/8, 2 1/4, 2 1/2, 2 3/4, 3, 3 1/8, 3 1/4, 3 1/2, 3 3/4, 4, 4 1/8, 4 1/4, 4 1/2, 4 3/4, 5, 5 1/8, 5 1/4, 5 1/2, 5 3/4, 6, 6 1/8, 6 1/4, 6 1/2, 6 3/4, 7, 7 1/8, 7 1/4, 7 1/2, 7 3/4, 8, 8 1/8, 8 1/4, 8 1/2, 8 3/4, 9, 9 1/8, 9 1/4, 9 1/2, 9 3/4, 10, 10 1/8, 10 1/4, 10 1/2, 10 3/4, 11, 11 1/8, 11 1/4, 11 1/2, 11 3/4, 12, 12 1/8, 12 1/4, 12 1/2, 12 3/4, 13, 13 1/8, 13 1/4, 13 1/2, 13 3/4, 14, 14 1/8, 14 1/4, 14 1/2, 14 3/4, 15, 15 1/8, 15 1/4, 15 1/2, 15 3/4, 16, 16 1/8, 16 1/4, 16 1/2, 16 3/4, 17, 17 1/8, 17 1/4, 17 1/2, 17 3/4, 18, 18 1/8, 18 1/4, 18 1/2, 18 3/4, 19, 19 1/8, 19 1/4, 19 1/2, 19 3/4, 20, 20 1/8, 20 1/4, 20 1/2, 20 3/4, 21, 21 1/8, 21 1/4, 21 1/2, 21 3/4, 22, 22 1/8, 22 1/4, 22 1/2, 22 3/4, 23, 23 1/8, 23 1/4, 23 1/2, 23 3/4, 24, 24 1/8, 24 1/4, 24 1/2, 24 3/4, 25, 25 1/8, 25 1/4, 25 1/2, 25 3/4, 26, 26 1/8, 26 1/4, 26 1/2, 26 3/4, 27, 27 1/8, 27 1/4, 27 1/2, 27 3/4, 28, 28 1/8, 28 1/4, 28 1/2, 28 3/4, 29, 29 1/8, 29 1/4, 29 1/2, 29 3/4, 30, 30 1/8, 30 1/4, 30 1/2, 30 3/4, 31, 31 1/8, 31 1/4, 31 1/2, 31 3/4, 32, 32 1/8, 32 1/4, 32 1/2, 32 3/4, 33, 33 1/8, 33 1/4, 33 1/2, 33 3/4, 34, 34 1/8, 34 1/4, 34 1/2, 34 3/4, 35, 35 1/8, 35 1/4, 35 1/2, 35 3/4, 36, 36 1/8, 36 1/4, 36 1/2, 36 3/4, 37, 37 1/8, 37 1/4, 37 1/2, 37 3/4, 38, 38 1/8, 38 1/4, 38 1/2, 38 3/4, 39, 39 1/8, 39 1/4, 39 1/2, 39 3/4, 40, 40 1/8, 40 1/4, 40 1/2, 40 3/4, 41, 41 1/8, 41 1/4, 41 1/2, 41 3/4, 42, 42 1/8, 42 1/4, 42 1/2, 42 3/4, 43, 43 1/8, 43 1/4, 43 1/2, 43 3/4, 44, 44 1/8, 44 1/4, 44 1/2, 44 3/4, 45, 45 1/8, 45 1/4, 45 1/2, 45 3/4, 46, 46 1/8, 46 1/4, 46 1/2, 46 3/4, 47, 47 1/8, 47 1/4, 47 1/2, 47 3/4, 48, 48 1/8, 48 1/4, 48 1/2, 48 3/4, 49, 49 1/8, 49 1/4, 49 1/2, 49 3/4, 50, 50 1/8, 50 1/4, 50 1/2, 50 3/4, 51, 51 1/8, 51 1/4, 51 1/2, 51 3/4, 52, 52 1/8, 52 1/4, 52 1/2, 52 3/4, 53, 53 1/8, 53 1/4, 53 1/2, 53 3/4, 54, 54 1/8, 54 1/4, 54 1/2, 54 3/4, 55, 55 1/8, 55 1/4, 55 1/2, 55 3/4, 56, 56 1/8, 56 1/4, 56 1/2, 56 3/4, 57, 57 1/8, 57 1/4, 57 1/2, 57 3/4, 58, 58 1/8, 58 1/4, 58 1/2, 58 3/4, 59, 59 1/8, 59 1/4, 59 1/2, 59 3/4, 60, 60 1/8, 60 1/4, 60 1/2, 60 3/4, 61, 61 1/8, 61 1/4, 61 1/2, 61 3/4, 62, 62 1/8, 62 1/4, 62 1/2, 62 3/4, 63, 63 1/8, 63 1/4, 63 1/2, 63 3/4, 64, 64 1/8, 64 1/4, 64 1/2, 64 3/4, 65, 65 1/8, 65 1/4, 65 1/2, 65 3/4, 66, 66 1/8, 66 1/4, 66 1/2, 66 3/4, 67, 67 1/8, 67 1/4, 67 1/2, 67 3/4, 68, 68 1/8, 68 1/4, 68 1/2, 68 3/4, 69, 69 1/8, 69 1/4, 69 1/2, 69 3/4, 70, 70 1/8, 70 1/4, 70 1/2, 70 3/4, 71, 71 1/8, 71 1/4, 71 1/2, 71 3/4, 72, 72 1/8, 72 1/4, 72 1/2, 72 3/4, 73, 73 1/8, 73 1/4, 73 1/2, 73 3/4, 74, 74 1/8, 74 1/4, 74 1/2, 74 3/4, 75, 75 1/8, 75 1/4, 75 1/2, 75 3/4, 76, 76 1/8, 76 1/4, 76 1/2, 76 3/4, 77, 77 1/8, 77 1/4, 77 1/2, 77 3/4, 78, 78 1/8, 78 1/4, 78 1/2, 78 3/4, 79, 79 1/8, 79 1/4, 79 1/2, 79 3/4, 80, 80 1/8, 80 1/4, 80 1/2, 80 3/4, 81, 81 1/8, 81 1/4, 81 1/2, 81 3/4, 82, 82 1/8, 82 1/4, 82 1/2, 82 3/4, 83, 83 1/8, 83 1/4, 83 1/2, 83 3/4, 84, 84 1/8, 84 1/4, 84 1/2, 84 3/4, 85, 85 1/8, 85 1/4, 85 1/2, 85 3/4, 86, 86 1/8, 86 1/4, 86 1/2, 86 3/4, 87, 87 1/8, 87 1/4, 87 1/2, 87 3/4, 88, 88 1/8, 88 1/4, 88 1/2, 88 3/4, 89, 89 1/8, 89 1/4, 89 1/2, 89 3/4, 90, 90 1/8, 90 1/4, 90 1/2, 90 3/4, 91, 91 1/8, 91 1/4, 91 1/2, 91 3/4, 92, 92 1/8, 92 1/4, 92 1/2, 92 3/4, 93, 93 1/8, 93 1/4, 93 1/2, 93 3/4, 94, 94 1/8, 94 1/4, 94 1/2, 94 3/4, 95, 95 1/8, 95 1/4, 95 1/2, 95 3/4, 96, 96 1/8, 96 1/4, 96 1/2, 96 3/4, 97, 97 1/8, 97 1/4, 97 1/2, 97 3/4, 98, 98 1/8, 98 1/4, 98 1/2, 98 3/4, 99, 99 1/8, 99 1/4, 99 1/2, 99 3/4, 100, 100 1/8, 100 1/4, 100 1/2, 100 3/4, 101, 101 1/8, 101 1/4, 101 1/2, 101 3/4, 102, 102 1/8, 102 1/4, 102 1/2, 102 3/4, 103, 103 1/8, 103 1/4, 103 1/2, 103 3/4, 104, 104 1/8, 104 1/4, 104 1/2, 104 3/4, 105, 105 1/8, 105 1/4, 105 1/2, 105 3/4, 106, 106 1/8, 106 1/4, 106 1/2, 106 3/4, 107, 107 1/8, 107 1/4, 107 1/2, 107 3/4, 108, 108 1/8, 108 1/4, 108 1/2, 108 3/4, 109, 109 1/8, 109 1/4, 109 1/2, 109 3/4, 110, 110 1/8, 110 1/4, 110 1/2, 110 3/4, 111, 111 1/8, 111 1/4, 111 1/2, 111 3/4, 112, 112 1/8, 112 1/4, 112 1/2, 112 3/4, 113, 113 1/8, 113 1/4, 113 1/2, 113 3/4, 114, 114 1/8, 114 1/4, 114 1/2, 114 3/4, 115, 115 1/8, 115 1/4, 115 1/2, 115 3/4, 116, 116 1/8, 116 1/4, 116 1/2, 116 3/4, 117, 117 1/8, 117 1/4, 117 1/2, 117 3/4, 118, 118 1/8, 118 1/4, 118 1/2, 118 3/4, 119, 119 1/8, 119 1/4, 119 1/2, 119 3/4, 120, 120 1/8, 120 1/4, 120 1/2, 120 3/4, 121, 121 1/8, 121 1/4, 121 1/2, 121 3/4, 122, 122 1/8, 122 1/4, 122 1/2, 122 3/4, 123, 123 1/8, 123 1/4, 123 1/2, 123 3/4, 124, 124 1/8, 124 1/4, 124 1/2, 124 3/4, 125, 125 1/8, 125 1/4, 125 1/2, 125 3/4, 126, 126 1/8, 126 1/4, 126 1/2, 126 3/4, 127, 127 1/8, 127 1/4, 127 1/2, 127 3/4, 128, 128 1/8, 128 1/4, 128 1/2, 128 3/4, 129, 129 1/8, 129 1/4, 129 1/2, 129 3/4, 130, 130 1/8, 130 1/4, 130 1/2, 130 3/4, 131, 131 1/8, 131 1/4, 131 1/2, 131 3/4, 132, 132 1/8, 132 1/4, 132 1/2, 132 3/4, 133, 133 1/8, 133 1/4, 133 1/2, 133 3/4, 134, 134 1/8, 134 1/4, 134 1/2, 134 3/4, 135, 135 1/8, 135 1/4, 135 1/2, 135 3/4, 136, 136 1/8, 136 1/4, 136 1/2, 136 3/4, 137, 137 1/8, 137 1/4, 137 1/2, 137 3/4, 138, 138 1/8, 138 1/4, 138 1/2, 138 3/4, 139, 139 1/8, 139 1/4, 139 1/2, 139 3/4, 140, 140 1/8, 140 1/4, 140 1/2, 140 3/4, 141, 141 1/8, 141 1/4, 141 1/2, 141 3/4, 142, 142 1/8, 142 1/4, 142 1/2, 142 3/4, 143, 143 1/8, 143 1/4, 143 1/2, 143 3/4, 144, 144 1/8, 144 1/4, 144 1/2, 144 3/4, 145, 145 1/8, 145 1/4, 145 1/2, 145 3/4, 146, 146 1/8, 146 1/4, 146 1/2, 146 3/4, 147, 147 1/8, 147 1/4, 147 1/2, 147 3/4, 148, 148 1/8, 148 1/4, 148 1/2, 148 3/4, 149, 149 1/8, 149 1/4, 149 1/2, 149 3/4, 150, 150 1/8, 150 1/4, 150 1/2, 150 3/4, 151, 151 1/8, 151 1/4, 151 1/2, 151 3/4, 152, 152 1/8, 152 1/4, 152 1/2, 152 3/4, 153, 153 1/8, 153 1/4, 153 1/2, 153 3/4, 154, 154 1/8, 154 1/4, 154 1/2, 154 3/4, 155, 155 1/8, 155 1/4, 155 1/2, 155 3/4, 156, 156 1/8, 156 1/4, 156 1/2, 156 3/4, 157, 157 1/8, 157 1/4, 157 1/2, 157 3/4, 158, 158 1/8, 158 1/4, 158 1/2, 158 3/4, 159, 159 1/8, 159 1/4, 159 1/2, 159 3/4, 160, 160 1/8, 160 1/4, 160 1/2, 160 3/4, 161, 161 1/8, 161 1/4, 161 1/2, 161 3/4, 162, 162 1/8, 162 1/4, 162 1/2, 162 3/4, 163, 163 1/8, 163 1/4, 163 1/2, 163 3/4, 164, 164 1/8, 164 1/4, 164 1/2, 164 3/4, 165, 165 1/8, 165 1/4, 165 1/2, 165 3/4, 166, 166 1/8, 166 1/4, 166 1/2, 166 3/4, 167, 167 1/8, 167 1/4, 167 1/2, 167 3/4, 168, 168 1/8, 168 1/4, 168 1/2, 168 3/4, 169, 169 1/8, 169 1/4, 169 1/2, 169 3/4, 170, 170 1/8, 170 1/4, 170 1/2, 170 3/4, 171, 171 1/8, 171 1/4, 171 1/2, 171 3/4, 172, 172 1/8, 172 1/4, 172 1/2, 172 3/4, 173, 173 1/8, 173 1/4, 173 1/2, 173 3/4, 174, 174 1/8, 174 1/4, 174 1/2, 174 3/4, 175, 175 1/8, 175 1/4, 175 1/2, 175 3/4, 176, 176 1/8, 176 1/4, 176 1/2, 176 3/4, 177, 177 1/8, 177 1/4, 177 1/2, 177 3/4, 178, 178 1/8, 178 1/4, 178 1/2, 178 3/4, 179, 179 1/8, 179 1/4, 179 1/2, 179 3/4, 180, 180 1/8, 180 1/4, 180 1/2, 180 3/4, 181, 181 1/8, 181 1/4, 181 1/2, 181 3/4, 182, 182 1/8, 182 1/4, 182 1/2, 182 3/4, 183, 183 1/8, 183 1/4, 183 1/2, 183 3/4, 184, 184 1/8, 184 1/4, 184 1/2, 184 3/4, 185, 185 1/8, 185 1/4, 185 1/2, 185 3/4, 186, 186 1/8, 186 1/4, 186 1/2, 186 3/4, 187, 187 1/8, 187 1/4, 187 1/2, 187 3/4, 188, 188 1/8, 188 1/4, 188 1/2, 188 3/4, 189, 189 1/8, 189 1/4, 189 1/2, 189 3/4, 190, 190 1/8, 190 1/4, 190 1/2, 190 3/4, 191, 191 1/8, 191 1/4, 191 1/2, 191 3/4, 192, 192 1/8, 192 1/4, 192 1/2, 192 3/4, 193, 193 1/8, 193 1/4, 193 1/2, 193 3/4, 194, 194 1/8, 194 1/4, 194 1/2, 194 3/4, 195, 195 1/8, 195 1/4, 195 1/2, 195 3/4, 196, 196 1/8, 196 1/4, 196 1/2, 196 3/4, 197, 197 1/8, 197 1/4, 197 1/2, 197 3/4, 198, 198 1/8, 198 1/4, 198 1/2, 198 3/4, 199, 199 1/8, 199 1/4, 199 1/2, 199 3/4, 200, 200 1/8, 200 1/4, 200 1/2, 200 3/4, 201, 201 1/8, 201 1/4, 201 1/2, 201 3/4, 202, 202 1/8, 202 1/4, 202 1/2, 202 3/4, 203, 203 1/8, 203 1/4, 203 1/2, 203 3/4, 204, 204 1/8, 204 1/4, 204 1/2, 204 3/4, 205, 205 1/8, 205 1/4, 205 1/2, 205 3/4, 206, 206 1/8, 206 1/4, 206 1/2, 206 3/4, 207, 207 1/8, 207 1/4, 207 1/2, 207 3/4, 208, 208 1/8, 208 1/4, 208 1/2, 208 3/4, 209, 209 1/8, 209 1/4, 209 1/2, 209 3/4, 210, 210 1/8, 210 1/4, 210 1/2, 210 3/4, 211, 211 1/8, 211 1/4, 211 1/2, 211 3/4, 212, 212 1/8, 212 1/4, 212 1/2, 212 3/4, 213, 213 1/8, 213 1/4, 213 1/2, 213 3/4, 214, 214 1/8, 214 1/4, 214 1/2, 214 3/4, 215, 215 1/8, 215 1/4, 215 1/2, 215 3/4, 216, 216 1/8, 216 1/4, 216 1/2, 216 3/4, 217, 217 1/8, 217 1/4, 217 1/2, 217 3/4, 218, 218 1/8, 218 1/4, 218 1/2, 218 3/4, 219, 219 1/8, 219 1/4, 219 1/2, 219 3/4, 220, 220 1/8, 220 1/4, 220 1/2, 220 3/4, 221, 221 1/8, 221 1/4, 221 1/2, 221 3/4, 222, 222 1/8, 222 1/4, 222 1/2, 222 3/4, 223, 223 1/8, 223 1/4, 223 1/2, 223 3/4, 224, 224 1/8, 224 1/4, 224 1/2, 224 3/4, 225, 225 1/8, 225 1/4, 225 1/2, 225 3/4, 226, 226 1/8, 226 1/4, 226 1/2, 226 3/4, 227, 227 1/8, 227 1/4, 227 1/2, 227 3/4, 228, 228 1/8, 228 1/4, 228 1/2, 228 3/4, 229, 229 1/8, 229 1/4, 229 1/2, 229 3/4, 230, 230 1/8, 230 1/4, 230 1/2, 230 3/4, 231, 231 1/8, 231 1/4, 231 1/2, 231 3/4, 232, 232 1/8, 232 1/4, 232 1/2, 232 3/4, 233, 233 1/8, 233 1/4, 233 1/2, 233 3/4, 234, 234 1/8, 234 1/4, 234 1/2, 234 3/4, 235, 235 1/8, 235 1/4, 235 1/2, 235 3/4, 236, 236 1/8, 236 1/4, 236 1/2, 236 3/4, 237, 237 1/8, 237 1/4, 237 1/2, 237 3/4, 238, 238 1/8, 238 1/4, 238 1/2, 238 3/4, 239, 239 1/8, 239 1/4, 239 1/2, 239 3/4, 240, 240 1/8, 240 1/4, 240 1/2, 240 3/4, 241, 241 1/8, 241 1/4, 241 1/2, 241 3/4, 242, 242 1/8, 242 1/4, 242 1/2, 242 3/4, 243, 243 1/8, 243 1/4, 243 1/2, 243 3/4, 244, 244 1/8, 244 1/4, 244 1/2, 244 3/4, 245, 245 1/8, 245 1/4, 245 1/2, 245 3/4, 246, 246 1/8, 246 1/4, 246 1/2, 246 3/4, 247, 247 1/8, 247 1/4, 247 1/2, 247 3/4, 248, 248 1/8, 248 1/4, 248 1/2, 248 3/4, 249, 249 1/8, 249 1/4, 249 1/2, 249 3/4, 250, 250 1/8, 250 1/4, 250 1/2, 250 3/4, 251, 251 1/8, 251 1/4, 251 1/2, 251 3/4, 252, 252 1/8, 252 1/4, 252 1/2, 252 3/4, 253, 253 1/8, 253 1/4, 253 1/2, 253 3/4, 254, 254 1/8, 254 1/4, 254 1/2, 254 3/4, 255, 255 1/8, 255 1/4, 255 1/2, 255 3/4, 256, 256 1/8, 256 1/4, 256 1/2, 256 3/4, 257, 257 1/8, 257 1/4, 257 1/2, 257 3/4, 258, 258 1/8, 258 1/4, 258 1/2, 258 3/4, 259, 259 1/8, 259 1/4, 259 1/2, 259 3/4, 260, 260 1/8, 260 1/4, 260 1/2, 260 3/4, 261, 261 1/8, 261 1/4, 261 1/2, 261 3/4, 262, 262 1/8, 262 1/4, 262 1/2, 262 3/4, 263, 263 1/8, 263 1/4, 263 1/2, 263 3/4, 264, 264 1/8, 264 1/4, 264 1/2, 264 3/4, 265, 265 1/8, 265 1/4, 265 1/2, 265 3/4, 266, 266 1/8, 266 1/4, 266 1/2, 266 3/4, 267, 267 1/8, 267 1/4, 267 1/2, 267 3/4, 268, 268 1/8, 268 1/4, 268 1/2, 268 3/4, 269, 269 1/8, 269 1/4, 269 1/2, 269 3/4, 270, 270 1/8, 270 1/4, 270 1/2, 270 3/4, 271, 271 1/8, 271 1/4, 271 1/2, 271 3/4, 272, 272 1/8, 272 1/4, 272 1/2, 272 3/4, 273, 273 1/8, 273 1/4, 273 1/2, 273 3/4, 274, 274 1/8, 274 1/4, 274 1/2, 274 3/4, 275, 275 1/8, 275 1/4, 275 1/2, 275 3/4, 276, 276 1/8, 276 1/4, 276 1/2, 276 3/4, 277, 277 1/8, 277 1/4, 277 1/2, 277 3/4, 278, 278 1/8, 278 1/4, 278 1/2, 278 3/4, 279, 279 1/8, 279 1/4, 279 1/2, 279 3/4, 280, 280 1/8, 280 1/4, 280 1/2, 280 3/4, 281, 281 1/8, 281 1/4, 281 1/2, 281 3/4, 282, 282 1/8, 282 1/4, 282 1/2, 282 3/4, 283, 283 1/8, 283 1/4, 283 1/2, 283 3/4, 284, 284 1/8, 284 1/4, 284 1/2, 284 3/4, 285, 285 1/8, 285 1/4, 285 1/2, 285 3/4, 286, 286 1/8, 286 1/4, 286 1/2, 286 3/4, 287, 287 1/8, 287 1/4, 287 1/2, 287 3/4, 288, 288 1/8, 288 1/4, 288 1/2, 288 3/4, 289, 289 1/8, 289 1/4, 289 1/2, 289 3/4, 290, 290 1/8, 290 1/4, 290 1/2, 290 3/4, 291, 291 1/8, 291 1/4, 291 1/2, 291 3/4, 292, 292 1/8, 292 1/4, 292 1/2, 292 3/4, 293, 293 1/8, 293 1/4, 293 1/2, 293 3/4, 294, 294 1/8, 294 1/4, 294 1/2, 294 3/4, 295, 295 1/8, 295 1/4, 295 1/2, 295 3/4, 296, 296 1/8, 296 1/4, 296 1/2, 296 3/4, 297, 297 1/8, 297 1/4, 297 1/2, 297 3/4, 298, 298 1/8, 298 1/4, 298 1/2, 298 3/4, 299, 299 1/8, 299 1/4, 299 1/2, 299 3/4, 300
--

DOCUMENTATION

HAMMONDS 4T-4A FUEL ADDITIVE INJECTOR

Manufactured by



HAMMONDS TECHNICAL SERVICES, INC.

15760 West Hardy, Suite 400

Houston, Texas 77060

Ph: 281-999-2900

Fx: 281-847-1857

E-Mail: hammonds@worldnet.att.net