

**OPERATING INSTRUCTIONS  
AND  
MAINTENANCE MANUAL  
FOR**

**HAMMONDS MODEL 600RO-1P\***  
\*VARIOUS PUMP MODELS

**FLUID POWERED  
ADDITIVE INJECTOR SYSTEM**

Manufactured by:



**HAMMONDS TECHNICAL SERVICES, INC.**

6807 West Little York Rd.  
Houston, Texas 77040

Phone: 281-999-2900

Fax: 713-896-9419

[www.hammondscos.com](http://www.hammondscos.com)

December 2021

# Hammonds Model 600RO-1P Injector Manual

## TABLE OF CONTENTS

SPECIAL NOTICE TO USERS	3
INSTALLATION AND PREPARATION FOR STARTUP	3
INSTALLATION CONSIDERATIONS OF BARE UNITS	4-7
PREPARATION FOR CALIBRATION AND STARTUP	7-8
CALIBRATION AND STARTUP	8-10
NORMAL OPERATION	10
PROPER INJECTION RATIOS	10-11
TROUBLE SHOOTING THE SYSTEM	11-12
PREVENTIVE MAINTENANCE	12-13
PREVENTIVE MAINTENANCE SCHEDULE	13
DESICCANT DRYER INSTRUCTIONS	14
TYPICAL ADDITIVE RATIO CHART	15

### ATTACHMENTS:

- SYSTEM LAYOUT (various arrangements)
- FLUID SCHEMATIC
- 600RO FLUID DRIVER
- GEAR REDUCER
- INJECTOR PUMPS
- SIGHT FLOW INDICATOR (if equipped)
- CALIBRATION GAUGES (if equipped)
- PROPER INJECTOR POSITIONING

# Hammonds Model 600RO-1P Injector Manual

## **SPECIAL NOTICE TO USERS** **PLEASE READ CAREFULLY** **BEFORE OPERATING EQUIPMENT**

This fluid powered additive injector system is designed to give consistent, dependable performance when operated and maintained according to manufacturer's recommendations. However, being a mechanical device, it is subject to failure from improper installation, wear, human error and operating environments beyond the control of the system. Because of this fact, it is the responsibility of the operator to make certain that:

- A. The system is installed properly.
- B. The system is being operated properly.
- C. The system is actually running during product transfer.
- D. The system is checked after the transfer operation to make certain the proper amount of additive was injected during the operation.

The performing of these checks by the operator eliminates the possibility of product not having the proper customer required additive ratio. Therefore, since the manufacturer cannot be present during each transfer operation, the responsibility for checking the performance of the system is that of the operator. Should there be any questions whatsoever, the operator should consult the distributor from whom the unit was purchased.

**DO NOT TAKE CHANCES.....DO NOT GUESS.....BE ABSOLUTELY CERTAIN THAT THE SYSTEM IS INSTALLED AND WORKING AS IT SHOULD.**

The user/ operator carries the final responsibility to make certain the system is operating properly.

## **INSTALLATION AND PREPARATION FOR STARTUP**

In most cases, the Hammonds fluid powered injector is shipped complete and ready to operate. The system should include appropriate fittings to suit your specific application. Flow direction is marked on the fluid motor housing, additive pumps and check valves. Any and all flow restricting devices such as ON/OFF ball valves, remote panels, sight flow indicators or suction strainers must be installed on the suction side of additive pumps.

### **CAUTION**

**Do Not Attempt To Use This Device Without Understanding And Following Proper Safety Precautions Regarding System Grounding, Fire Safety And Special Handling For Potentially Dangerous Additives.**

Consult your Engineering Department for their specific instructions. Make certain all personnel involved with this system are thoroughly familiar with safe operating practices.

If your system has been purchased "bare," consult your equipment distributor for help in selecting hoses, fittings and other related accessories. Selection of materials compatibility, location of unit within the system, effect of the unit on the system and injection point of the additive are also factors that should be discussed by factory authorized personnel.

If no factory-authorized distributor is available, consult the factory directly for assistance.

# Hammonds Model 600RO-1P Injector Manual

## **INSTALLATION** **CONSIDERATIONS OF BARE** **UNITS**

Hammonds additive injector systems may be installed in a wide variety of applications, systems, and operating conditions. **This Manual Makes The Assumption That The Purchaser Has Consulted With A Factory Authorized Distributor Or The Factory And Has Approval For The Application And Installation.** If this is not the case, listed below are a few considerations that should be reviewed before installing a unit in an existing system.

### **FLOW CONSIDERATIONS**

The Hammonds Model 600 requires a minimum of 20 and up to 200 GPM to deliver consistent ratios. This does not mean that the system cannot be used in cases where startup and shutdown fall under the 20 GPM minimum. However, these installations require calibration to compensate for the lower flow rates during these periods of operation. Check with the factory if you have any questions in the area of performance.

### **MATERIALS OF CONSTRUCTION**

The standard material in a Hammonds Model 600 fluid driver is anodized cast aluminum housing. Optional material is carbon steel.

### **INJECTION POINT OF ADDITIVE**

Some additives may adversely affect other components in the product handling systems, for example seals in meters, valve seals, aluminum and filter elements to name a few. The Hammonds injector systems do

an excellent job of mixing the additive in the fuel systems, while injecting at an almost continuous rate. Because of this superior mixing and very small concentration of additive in any one point, many customers feel that this is not a problem. **SOME DO**, and therefore, should use their own judgment as to the effect of these additives. **Hammonds Technical Services, Inc. Can Only Advise You Of The Possible Hazards.** It is up to the owner of the equipment to decide his preference as to location of the additive injection point. It can be placed at any point in the system. The 600 comes with the injection point directly ahead of the fluid motor for good blending. It can be located elsewhere very easily. If the injection point is moved from the body of the injector, the 1/4" tapped hole must be plugged, the inlet check valve moved to the new location, and the injection tubing rerouted to the new location. An injection check valve must always be used regardless of location.

### **WHERE TO PHYSICALLY MOUNT THE INJECTOR ON A REFUELER**

If the unit is to be installed upstream of the filter separator (monitor), it can be placed at any place that is convenient between the system pump and the filter separator. If installation is to be downstream of the filter separator, the most ideal location is just after the filter separator, ahead of the de-fueling valve or pressure control valve. The unit can be installed between the de-fueling valve and the hose reels. However, this will cause some loss of efficiency in the de-fueling capability, since the system pump will be pulling through the injector motor. It does not harm the unit to run backwards. If the system is installed after the pressure control valve, overall flow may be affected since the control valve monitors system pressure and compensates accordingly. The nominal backpressure produced by the injector could have an effect on the operation of the pressure control valve and its reaction to changing system

# Hammonds Model 600RO-1P Injector Manual

conditions, you may affect flow volumes. If you are in doubt about this particular subject, and feel that your chosen mounting location will affect the valve, consult the factory. Most systems can be adjusted to compensate for this minor loss.

Model 600 can be mounted in most any convenient location. The standard product connection is 3" 150# flange. The performance of the 600 is not affected by changes in pipe direction or other components such as valves, strainers or meters directly before or after the injector. However, care should be taken in placing the unit too close to other items such as turbine meters that may be sensitive. Consult other manufacturers for advice in placing the fluid motor adjacent to their specific equipment.

## MOUNTING ATTITUDE

The Model 600 can be mounted in a horizontal, vertical, or even a slanted pipe with one condition. The main motor shaft that powers the injector **MUST always** be horizontal. If this is not done, premature wear will occur in the unit, causing close design tolerances in the unit to become excessive. This will lead to a loss in the system's ability to operate correctly at low flow rates. **Study The Installation Drawing At The End Of The Manual Carefully. Consult Your Local Distributor Or The Factory If You Have Any Questions Whatsoever.**

## LOCATION RELATIVE TO METERS

Hammonds injectors can be installed at any point in the system. If the unit is placed upstream of the meter, it will precisely inject additive to the system, whether a single hose or dual hoses are used.

## SPACE REQUIREMENTS

The system is designed with easy service in mind. The entire rotor and pump assembly can be removed, where possible,

from the housing without disturbing the system piping. Ample room should be reserved in the installation for this removal. The injector pump is removed from the side on which it is mounted. Approximately 2" should be allowed for complete removal of the pump. Should the fluid motor need service, it is typically done from the backside. A clearance of 12" is required on the backside to remove the rotor and rear side plate. An equal amount is necessary to remove the rotor and shaft from the front, or injector side. Also, allow room for the operator to have visual access to the pump controls for calibration adjustment purposes.

## ON/OFF OPERATION

There are two methods for providing ON/OFF operation to the system. The first uses a remote panel that includes a special rotary valve connecting the additive tank and injector appropriately, and the other is a simple ball valve placed in the additive supply line that connects the additive storage tank and the injector. Although the valve can be located at any point, it works best located as close to the injector suction as possible. The valve should be a simple two-way, 1/4" stainless steel ball valve. Make certain that the "trim" or seal in the valve is Teflon®, or an elastomer that is compatible with the additive to be used.

Since the injector is a diaphragm type pump, it can be operated "DRY" without damage. When the additive supply valve is turned OFF, the injector simply maintains a suction on the additive line until the valve is opened for operation. The injector immediately begins pumping when the valve is returned to the ON position. An injector can operate indefinitely in the OFF position, but if this is going to be normal practice, simply mark the stroke setting on the dial and stroke the pump to zero and lock it down. This will extend the life of all the

# Hammonds Model 600RO-1P Injector Manual

moving parts. When injection is needed, set the dial to the marked position.

When a Hammonds remote operating panel is used, the OFF position allows the injector pump to recirculate the additive back to the additive storage tank.

## **CAUTION**

**NEVER, NEVER** turn the injector off by placing an ON/OFF control valve on the discharge side of the pump. This blocks the discharge of the pump, causing damage to the diaphragms and pump parts. If the system is equipped with a relief valve, the diaphragm could rupture after repeatedly blocking the discharge. This would result in an uncontrolled leak of additive, as well as preventing the system from operating.

## **LOCATION OF THE ADDITIVE**

The additive tank should always be placed as close to the injector as possible. Ideally, the tank should be at the same level, or slightly higher than the unit. If this is not possible, the injector will have to pull a suction lift. Special care should be taken to assure there are absolutely no leaks in the suction line of the injector. A pinhole will prevent the system from priming and/or operating efficiently. Tape all threaded connections carefully with Teflon® sealant. The injector should not be required to lift additive more than four (4) feet.

## **ADDITIVE PAILS AND SIPHON TUBES**

The popular use of an additive pail equipped with a siphon tube is a convenient way to store additive without the expense of a custom made tank. But, when the pail is used out-of-doors, in the weather, certain precautions must be considered. The top of the pail must be sheltered from the rain and snow. If rain and/or snow is allowed to accumulate on the top of the pail, some of the water will make its way into the pail,

thereby contaminating the additive. The water that leaks in will go to the bottom of the pail as it is heavier than most fuel additives. The inlet of the siphon tube is close to the bottom of the pail and will pick up this water injecting it causing problems.

Caution must be used when changing a pail of additive. Before removing the siphon tube, dry the area of the pail around the adapter which threads the siphon tube into the pail. Disconnect the supply line to the pump. Be careful to keep the ends of the line clean and dry. Now unthread the siphon tube assembly from the pail. Examine the tube for any contaminants and the threads for any dirt or water. Make certain that the top of the new additive pail is clean and dry. Install the siphon tube assembly and reconnect the supply line. Examine the condition of the desiccant dryer tube attached. Replace the desiccant dryer with a new one when it is  $\frac{3}{4}$  pink. This will insure your additive supply is clean and dry. Reinstall the pail in its sheltered, dry location.

## **TUBING AND CONNECTIONS**

High-density Synflex® tubing is provided with every system for refueler installation. Although stainless steel tubing would be more desirable, the poly tubing is easier to install and less expensive. Make sure all tubing is carefully secured and grouped together, whenever possible. USE CAUTION TO NOT CRUSH OR KINK TUBING WHEN INSTALLING. Tubing runs should be as straight and level as possible with a minimum of low spots or "traps" that can trap air during startup. Tubing should not be allowed to "thump" or vibrate during operation, as this will cause premature fatigue and failure.

# Hammonds Model 600RO-1P Injector Manual

## INSTALLING THE REMOTE PANEL

The remote operating panel, RP1-1, uses a rotary valve that connects injector suction, discharge, additive tank and injection point at the proper time for the system functions of "INJECT", "OFF", "BLEED", and "CALIBRATE". When installing a remote panel, make certain connecting lines are level, well secured and as short as possible. If installing on a refueler with flow rates over 180 GPM, use the 1/2" line for the suction supply from the additive tank to the panel sight flow indicator continuing to the pump suction. The 3/8" line is for the discharge runs. Improperly connected lines will generate very confusing operating conditions that are difficult to diagnose. FOLLOW THE INSTRUCTIONS WITH THE UNIT CAREFULLY.

## PREPARATION FOR CALIBRATION AND STARTUP

**Before Attempting To Start The System Or Make Calibrations, Please Read The Following Information Carefully.**

During startup and calibration, you will be bleeding the system of air, collecting samples of additive during the calibration and checking for possible leaks throughout the system. Provisions should be made for collection or clean up of spilled fluid. Attempts should be made to minimize losses during these procedures. If the additive being handled is flammable, fire safety precautions should be taken. (Since the installation may also be tested at this time, extreme caution should be used in checking for leaks of the main line.) If you wish to set the system up for leak-free testing and calibration with zero spillage, please consult your local distributor or the factory for help in

doing so. Hammonds is glad to suggest any necessary parts and procedure for "zero spill" startup and calibration.

## A WORD ABOUT ADDITIVES

Most additives being used in fuels today have at least some degree of toxicity. Many are very dangerous. Extreme caution should be taken in handling additives. Remember, the additive is placed under pressure when being injected into the line, and when collecting samples during calibration, some spillage may occur. Be careful, wear protective clothing including eye protection. Be sure you have facilities to wash off any additive that may come in contact with your skin. Read all additive manufacturers safety precautions and Material Safety Data Sheets, following them to the letter.

## HERE IS WHAT IS NEEDED:

- ❑ Appropriate safety protection equipment.
- ❑ Eye protection in the form of safety goggles.
- ❑ An assortment of wrenches that fit the various fittings on the system. Note: two (2) 10" crescent wrenches will normally take care of any adjustments to fittings you may have to make. One to hold the fitting, and one to hold the adjacent fitting.
- ❑ A marked graduated glass bottle that is marked in either cc's or ounces. (At least 16 oz.)
- ❑ A stop watch.
- ❑ A means of determining the flow rate of the main system.
- ❑ A small pocket calculator is helpful.
- ❑ A clipboard is helpful with pad of paper.
- ❑ AT LEAST ONE, AND PREFERABLY TWO HELPERS
- ❑ A large container or catch basin to collect the output of the pump while

# Hammonds Model 600RO-1P Injector Manual

you are not actually calibrating the system.

**REMEMBER:** Any plumbing system varies with temperature and fluid being pumped. The system also changes as parts of the pump wear.

## **CALIBRATION AND STARTUP**

**IF YOUR INJECTOR SYSTEM IS EQUIPED WITH CALIBRATION GAUGES, FOLLOW THE INSTRUCTIONS FOR THEIR USE IN THE BACK OF THIS MANUAL.**

**Please Follow These Steps In Their Given Order. Read Them Over Carefully Before Starting, Then Follow Them To The Letter. If There is Any Part Of The Procedure That Is Not Clear, Consult Your Local Distributor Or The Factory Directly.**

1. Make certain the additive tank is full of the proper additive.
2. Open the suction valve between the tank and the pump. This valve should be located at any point between the additive tank and the injector.
3. All systems are calibrated at the factory to customer specified requirements. So if adjustments are required, they should only be minor. If this is the case, go directly to step 7.
4. If you are starting from scratch in the calibration and adjustment, loosen the stroke adjustment locking screws located on the bottom of the pump body. This will allow the stroke adjustment to be moved.

5. Adjust the stroke adjustment knob located on the pump body to approximately 50%. **CAUTION:** Do not turn this adjustment knob with excessive force. If this is difficult to adjust, simply rotate the main rotor shaft, by producing flow in main product line.

6. Lock the stroke adjustment locking screw down firmly.

THE FOLLOWING STEP (#7) IS FOR A SYSTEM NOT EQUIPPED WITH A REMOTE PANEL

7. Set the calibration valve (3-way valve) in the "calibrate position." This is done by making certain that the handle on the valve is positioned so that additive will exit through the short tube. A check valve sized for the application should be installed on the end of this tube. If no check valve is there, contact your distributor or the factory.

8. Make certain all product connections going to and from the system are in their proper, locked position to ensure safe, leakproof flow of product through the fluid motor. Double check the flow direction arrows located on the fluid motor housing, and check valves above and below the pump head to ensure that the system is installed properly.

9. At this point, consider the information you will have to gather during the next few steps of the calibration process.

A. What will the product flow rate through the unit be?

B. What is the length of time that the calibration will cover?

# Hammonds Model 600RO-1P Injector Manual

C. What is the amount of additive in ounces or cc's that you will need to collect based on the duration of the calibration?

## **You Should Have the Answer To All Of These Questions Before Your First Trial Run.**

10. Before starting the main product flow through the system, make certain everyone understands that you will run the system for, let's say, one (1) minute or one hundred (100) gallons. Even shorter runs are fine, especially if you are running at high flow rates.

11. Place the measured graduate under the calibration tube. (The short tube with the check valve on the end.) Put on your eye protection.

12. At the command of the timekeeper, or the person watching the flow meter, start the main product pump.

13. Give the system a few seconds to gather momentum and flow through the fluid motor. Confirmation that the fluid motor is running may be obtained by removing the stroke adjustment knob(s) and locking screw(s) so that the graduated power frame cover may be removed. This will expose the pump drive bearing mounted on the end of the main motor shaft. If the fluid motor is operating properly, this bearing will be turning around in an eccentric motion.

14. If the pump is being started up for the first time, it will take a few seconds to prime itself and begin discharging fluid from the calibration tube. Is your eye protection on? If not, **PUT IT ON NOW!**

15. As soon as the pump begins discharging a clear, air free stream of

fluid from the calibration tube, you are ready to begin your calibration. At this point, the system is primed.

16. You will now prepare to make your first actual calibration run. Empty your collected additive back into the tank, putting the bottle back under the calibration tube. **IF YOUR SYSTEM IS EQUIPPED WITH A REMOTE PANEL, SCREW THE CALIBRATION BOTTLE INTO THE RECEPTACLE ON THE PANEL.** Notice the setting on the main product meter, set your stop watch at zero.

17. When ready, start the system again. Stop it at the decided time interval or meter reading. Calculate the amount of product that traveled through the system. Measure the amount of additive gathered, and record the amount of elapsed time.

18. It will be at this time that you will have to calculate how much additive you should have collected for the amount of fuel that the system pumped. This, of course, depends upon the ratio that is required. The following example is the easiest way of explaining the procedure without getting too complicated. It is not the only way...use it if you like.

Example condition:

Amount of product pumped: 500 gallons

Ratio of additive desired: 250 PPM (Parts per million)

It is assumed that the operator will know how much product is being pumped through the system in a given length of time. If, for example, you have a meter that registers the flow in gallons, you simply record the gallons at the beginning of the timed run, and then again at the end of the run. If you run for one (1) minute, you simply subtract the beginning number on the meter

# Hammonds Model 600RO-1P Injector Manual

from the number registered after the run. This will give you the gallons per minute (GPM). Having to make this calculation is the only reason for timing the run. You can accomplish the same result by just watching the meter and stopping the system when you have totaled the desired amount of gallons through the system. In any case, you must know the amount of product passing through the system before calibration can begin.

First, change the gallons pumped into ounces by multiplying total gallons (in our example 500) by 128 (128 oz. to a gallon). The answer is 64,000 ounces.

Second, divide by 1,000,000. The answer is .064. Since you are dealing in 1/1,000,000 (one part per million) of the total for your ratio, you must find out what 1/1,000,000 of the 500 gallons is, .064 ounces is 1/1,000,000th (one part per million) of 500 gallons of fuel pumped.

Third, multiply the .064 x 250 (for 250 PPM). The answer is 16 ounces.

So, you should collect 16 ounces of additive for every 500 gallons of fuel pumped.

These are all large, round numbers. You may, for example, only be running at 100 GPM, not 500. Use the same formulas and change the numbers.

No two systems will ever perform exactly the same. For this reason, the procedures given for calibration are general in nature. Obviously, it is impossible to provide a graph or table that would be absolutely accurate in every case. With that in mind, all tables and graphs should be used as general guidelines. Remember, the calculated, timed and measured output that you gather is absolute. Trust your figures and your calculations.

## **NORMAL OPERATION**

Following initial start up and calibration, the system requires very little attention other than making certain that additive tank levels are maintained. Operators will quickly become accustomed to the performance of the system by observing the Suction Sight Flow Indicators. On-spec injection will cause a certain response in the indicators, and with some practice, operators will be able to observe the system and quality performance at a glance. *This does not mean that system calibration should not be periodically checked!* However, during a busy workload, these visual checks will provide assurance to the operator that the system is functioning.

Assuming the system remains set up and operating at least intermittently, calibration is required perhaps every 1 – 3 months. Good record keeping of additive inventory and use levels compared to fuel handled can give a good indication that additive ratio is on specification. Test such as the refractometer for FSII content should be the final test to verify additive injection ratios.

See the section on preventative maintenance for suggestions as to regular maintenance.

## **PROPER INJECTION RATIOS**

Your system should be equipped with some sort of calibration device, i.e.; suction calibration gauge, additive meter, Hammonds remote panel with pressure check valve, or a simple pressure check valve on the end of the bleed tube. If it is not equipped with any of these devices, calibration of your system will be done using only atmospheric pressure. Volumetric calibration at atmospheric pressure is not recommended. It will not

# Hammonds Model 600RO-1P Injector Manual

necessarily bring you within an acceptable range of additive injection. The only true evaluation for proper ratio is the ASTM D-5006 evaluation for fuel system ice inhibitor (FSII). Do not depend on volumetric calibration to ensure on-spec performance because line pressures can vary and additive injector parts wear over time. Contact Hammonds Fuel Additives, Inc. for supply of quality fuel system ice inhibitor and fuel testing procedures.

## **TROUBLESHOOTING THE SYSTEM**

The following conditions are given as a means of troubleshooting the system. Each condition lists a number of possible causes. In most cases, trouble can be solved by the use of this section. Please read it carefully before attempting repairs or making any changes in the system.

### **FLUID MOTOR IS NOT TURNING**

A. Insufficient flow to turn the motor. A minimum flow of about 20 GPM needed to start the system.

B. A rag or some other object is jammed in the line preventing the fluid motor from turning.

C. A diverter valve is blocked downstream of the system, blocking the fuel flow through the system.

D. On a truck or hydrant system, a de-fueling valve is left open starving the fluid motor for product flow.

E. If the unit has been recently serviced internally, the rotor might be installed backwards. Consult the factory before disassembly.

F. The fluid motor may be installed in the wrong direction of flow.

### **FLUID MOTOR IS TURNING AND PUMP RUNS, BUT WITH NO OUTPUT**

A. Pump is air-locked. In some cases where there is a very long line running from the injector head and the point of injection into the system, there is sufficient air volume to cause the pump to act as a compressor. It is not able to open the valves throughout the system and therefore, cannot pull a suction of fluid to the pump. Loosen the connection at the injection point check valve and allow it to remain open until the pump begins pumping.

B. One or more of the suction or discharge check valves are not working. While the pump is running, tap on the side of the valves, one at a time. This will generally jar them loose. The poppets and seals are very small, and will sometimes become stuck. After the valve is loosened and has a supply of fluid, usually it will not stick again.

C. The pump is not getting additive. Check that the valve between the pump and the tank is open. Check all the connections in the line between the pump and the tank.

D. The vent on the tank is not open causing the pump to pull a vacuum. Open the vent. Check to see if the cap has been removed from the dryer cartridge, if so equipped.

E. The pump stroke is set at zero.

F. The additive tank is empty...don't laugh, it happens.

### **INJECTOR IS OPERATING BUT WITH REDUCED OUTPUT**

A. Leaking suction line or trash in one of the pump check valves.

B. Air leak in suction side of system. Note: leaks may be anywhere upstream of the additive pump, through the remote panel back to the additive container.

C. Defective tubing that has tiny holes or deterioration from ultra violet light.

D. Leaks in threaded connections - suction side.

# Hammonds Model 600RO-1P Injector Manual

E. Injector diaphragm may be pulled out in back, causing injector to pump in forward portion of stroke only. This will not create a visible leak, but will reduce output by 50%. It usually happens after many hours of operation.

F. On a refueler with flow rates over 180 GPM injecting FSII, the pump may be starved for fluid. The suction line from the additive source to the remote panel to the inlet of the additive injector pump must be 1/2" OD tubing. Some older systems in the field are equipped with 3/8" OD tubing on the suction side. This could be the problem.

G. If equipped with a plunger pump, the plunger seal (o-ring) may be worn and needs replacing. Also, check plunger for signs of wear, replace if necessary.

H. Performance of the system is slipping. Fluid motor vanes are badly worn. This would only be probable after a very high number of hours of operation.

## **PREVENTIVE MAINTENANCE**

1. Make certain to use only clean, fresh additive that has been stored in a sealed container. Most additives are moisture sensitive. Some will form heavy crystals if allowed to accumulate moisture. These crystals will stop the pump in very short order, or cause calibration to be changed due to clogging of the valves and other parts.

2. Check the additive suction strainer or filter screen in the sight flow indicator, if so equipped, at least every six months. More often if there is an indication of possible contamination.

3. Check the system for leaks at every use. This is an extremely important safety procedure, since some additives are flammable, caustic and corrosive.

4. Check for leaks from the seal that is located at the exit point of the injector output shaft in the side plate housing. This should be done at each operation. Leakage at this point usually indicates that the mechanical

seal inside the fluid motor housing is leaking. A leak here will be jet fuel, and is not only dangerous from a fire standpoint, but will quickly ruin the bearings on the rotor shaft, since all lubricant will be washed away.

5. Check the fittings for leakage around the suction strainer or sight flow indicator, if one is used on the pump. Check this fitting each time the filter is changed or cleaned. Make certain there are no leaks in the suction line. A very small leak will either change the operation of the pump or prevent it from operating altogether.

6. Visually check around the pump head and make certain there is no leaking of additive around the fluid end. If there is, check the tightness of the head bolts. (40 inch pounds each)

7. Check the grease around the eccentric drive bearing in the pump every 12 months. Use good quality waterproof grease.

8. It is recommended that the injector diaphragm or plunger o-ring be changed at least every 12 months. Every 6 months under extreme operating conditions. Doing so will prevent unexpected failures and unscheduled downtime.

Hammonds injectors are very dependable. If installed properly and sized appropriately to the application, they require very little maintenance. With the exception of the grease on the eccentric bearing mentioned in STEP 7, there is very little actual maintenance to do. Remember; keep the additive and the suction filter clean. If you have problems with the pump working, it is usually in the suction side of the system (between the additive tank and the injection pump). Suction lines and fittings are notorious for leaking just enough to prevent the system from working. Always check to ensure optimum suction conditions, should problems occur.

Remember, a leak in the suction allows air from the outside to be introduced into the system. It does not always mean a visible leak of additive. If the pump loses its

# Hammonds Model 600RO-1P Injector Manual

prime or output is erratic, chances are good that there are problems in the suction side.

Otherwise, if it is working...leave it alone!

## PREVENTATIVE MAINTENANCE SCHEDULE

**NOTE:** It is important to read the previous pages on preventative maintenance. These intervals are general, and may vary according to individual applications and severity of service.

SERVICE FUNCTION	0-4 HRS DAILY	5-8 HRS DAILY	8+HRS DAILY
Check additive filter screen	Monthly	Monthly	Monthly
Check system for additive/fuel leaks	Daily	Daily	Daily
Inspect diaphragms/plunger seals	12 Months	6 Months	3 Months
Replace diaphragms/plunger seals	12 Months	As needed	As needed
Check eccentric bearing grease	6 Months	3 Months	Monthly
Check stroke adjustment parts for looseness	Monthly	Monthly	Monthly
Replace stroke adjustment parts	24 Months	As needed	As needed
Disassemble and inspect fluid motor housing and internal parts	24 Months	12 Months	8 Months

# Hammonds Model 600RO-1P Injector Manual

## DESICCANT DRYER

Your Hammonds additive system may include either a custom additive tank or one of several Sight Flow Indicators. Both custom tanks and the 5-SF and 55-SF Sight Flow Indicator come equipped with a desiccant dryer cartridge. These units come in several different sizes.

Most systems come equipped with the standard 3/4" cartridge. This unit is attached to the tank or Sight Flow Indicator via a short length of black rubber hose. The cartridge has a housing constructed of a clear poly material and is filled with a blue colored desiccant crystal. All these units are shipped from the factory with a rubber cap on the unattached end of the cartridge.

Some systems may come equipped with a large canister measuring approximately 2" diameter and 10" in length. These units perform the same function, just on a larger scale. Due to their greater capacity, they last longer between service. These units are sealed from the factory by a small, plastic plug or rubber cap, which is located either on the bottom or one side of the canister.

The purpose of all desiccant dryers is simply to remove moisture from the air as the system breathes. All tanks or portable sources of additive supply must be vented to atmosphere in order for the injector to operate. If moisture in this venting air is not removed, some additives are either ruined or seriously damaged. Fuel system icing inhibitor (FSII) FIZZY®, for example, is designed to seek out water in a fluid. So, when enough moisture is absorbed into the container, the FIZZY® (FSII) is diluted, and at some point, will be ruined. Biobor® JF, an anti-fungal material, will form crystals in the presence of moisture and not only perform unsatisfactorily as an additive, but will stop up pumps and lines as well.

The following instructions apply to all desiccant cartridges:

A. Remove the rubber cap or plug when the system is placed into service.

B. Observe the color of the desiccant. The original color is blue. As moisture is absorbed, the color will change to pink. When the cartridge is 3/4 pink, it should either have its contents removed, dried and replaced, or the entire unit replaced.

**NOTE:** The contents can be removed from plastic container, placed on a pan and baked at 400°F in a conventional oven until the moisture has been removed. When the color blue returns, the cooled material may be reinstalled into the cartridge and is again ready for service.

Color change and cartridge life is totally dependent on humidity. The more moist the air, the shorter the life. Keeping it dry is especially important if additive is not consumed rapidly. Check daily and service as needed.

# Hammonds Model 600RO-1P Injector Manual

## TYPICAL ADDITIVE RATIO CHART

<u>GALLONS</u>	<u>135 PPM*</u>	<u>270 PPM*</u>	<u>1250 PPM*</u>
100	1.7	3.4	16.0
200	3.4	6.9	32.0
400	6.9	13.8	64.0
500	8.6	17.2	80.0
700	12.0	24.0	112.0
1000	17.2	34.5	160.0

\*PPM amounts shown are in ounces

# Hammonds Model 600RO-1P Injector Manual

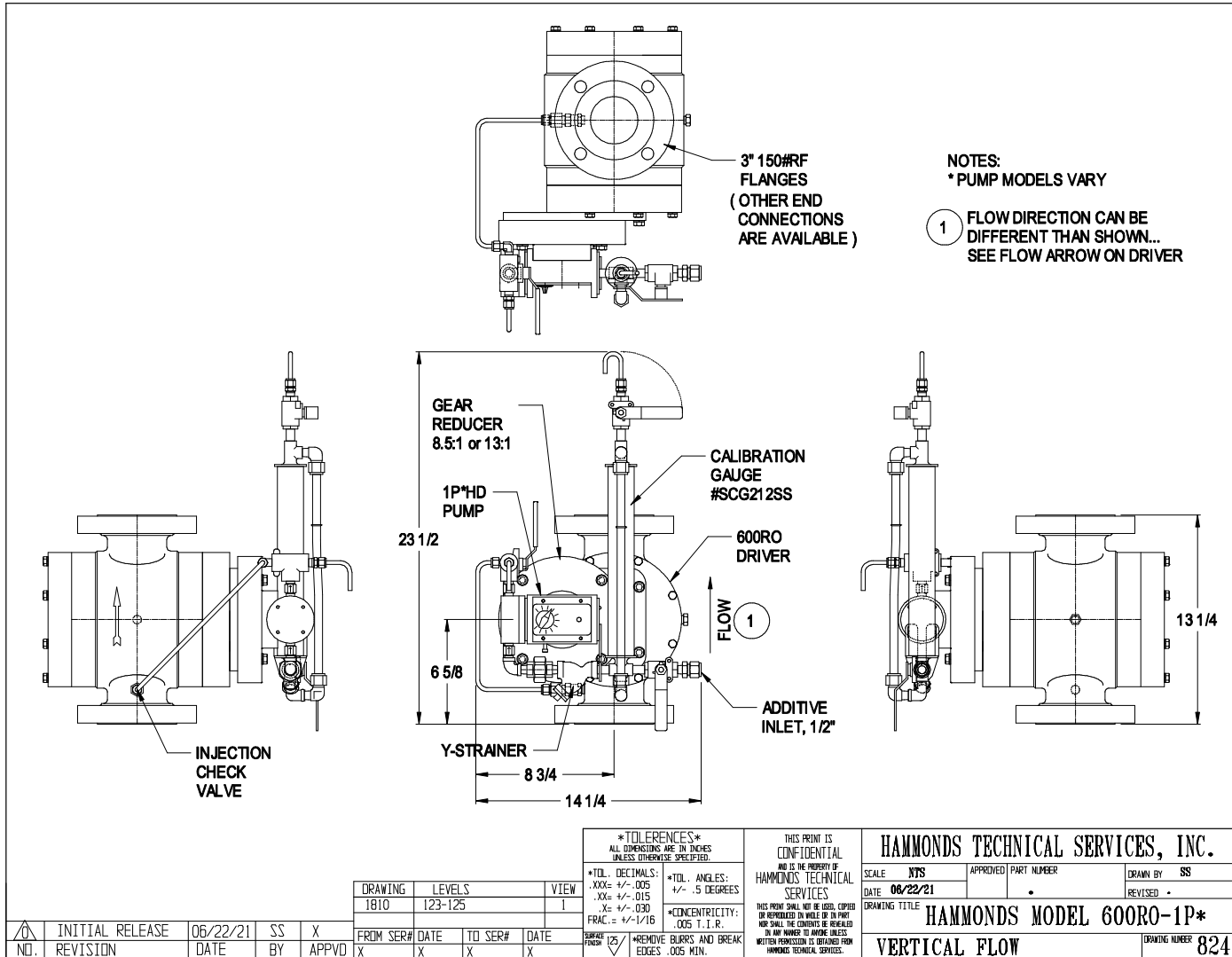

# Hammonds Model 600RO-1P Injector Manual

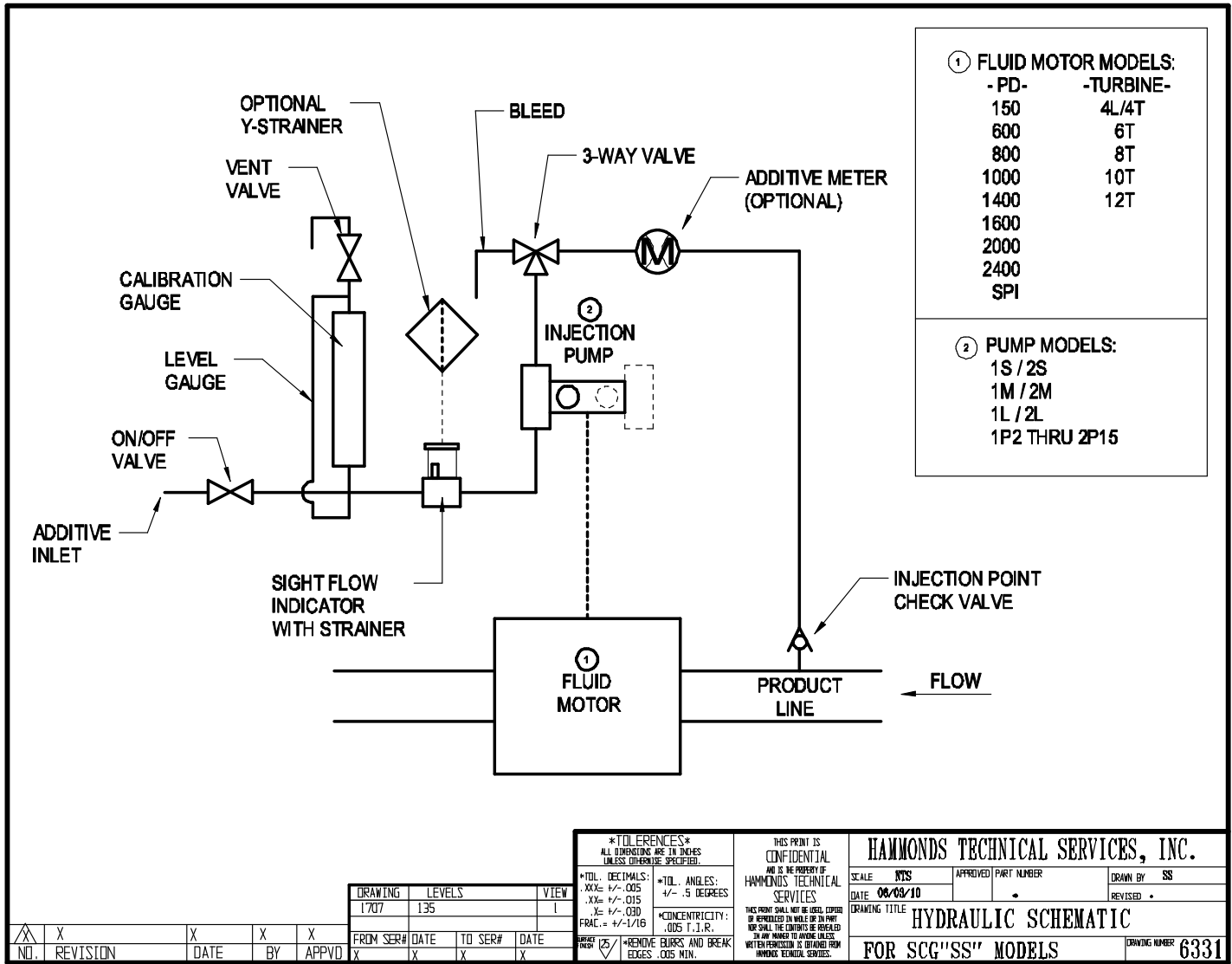

# Hammonds Model 600RO-1P Injector Manual

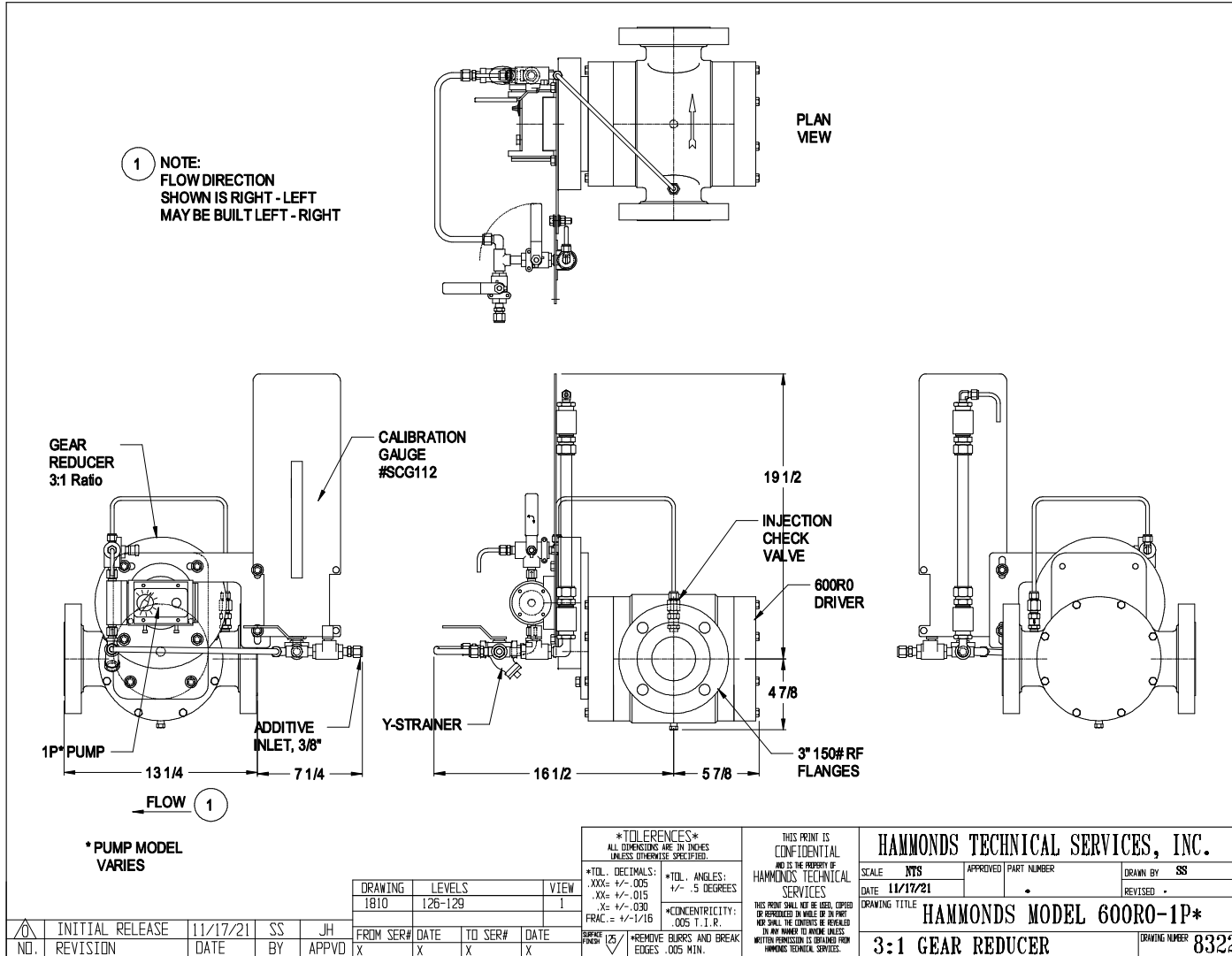

# Hammonds Model 600RO-1P Injector Manual

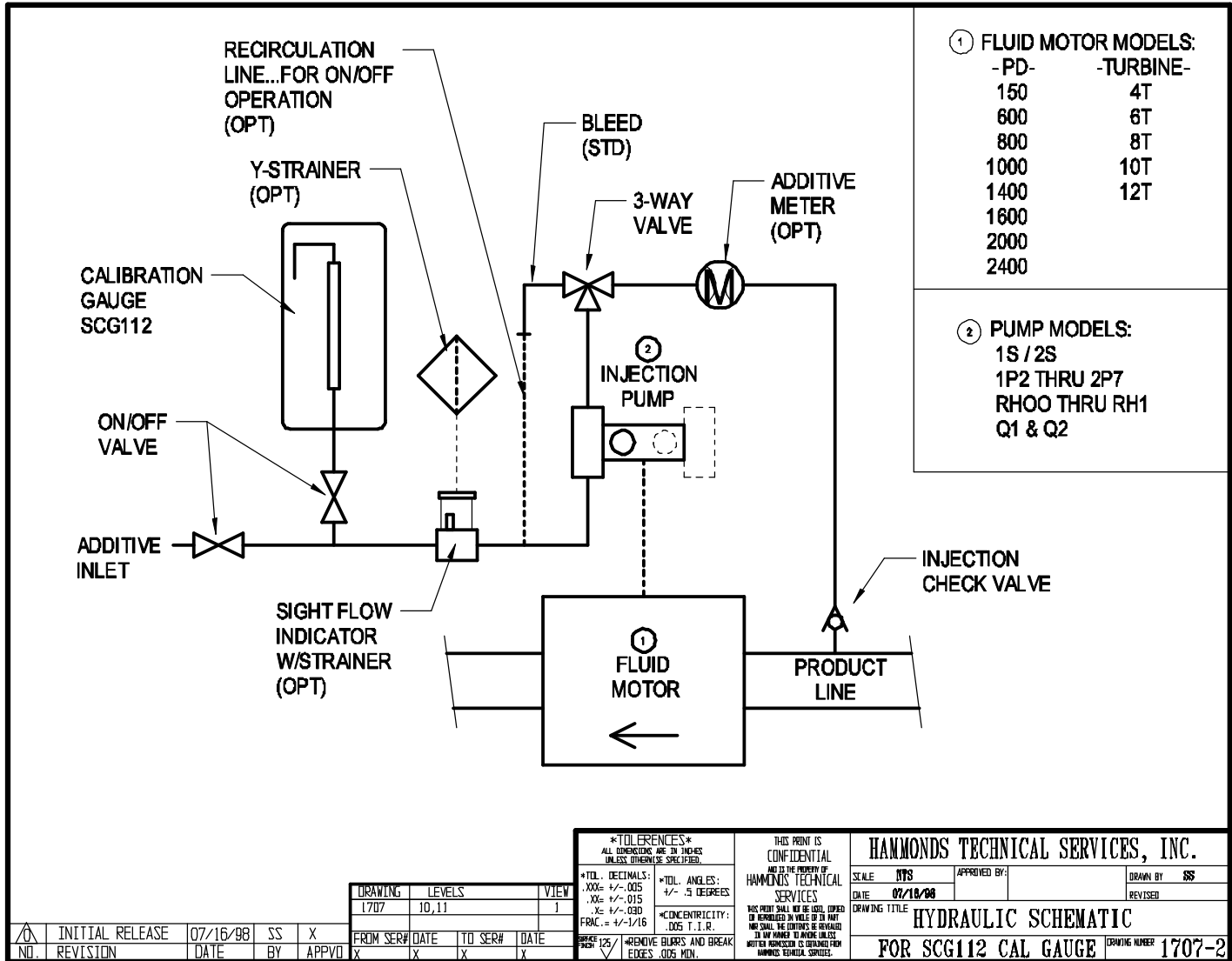

# Hammonds Model 600RO-1P Injector Manual

ITEM	PART NO.	QTY.	DESCRIPTION
1			
2			
3	212272	1	BEARING, SHIELDED
4	881120	1	BEARING, SEALED
5	881121	2	SNAP RING
6	881119	3	SNAP RING
7	212473	1	HD BACK PLATE
8	212273	1	SHAFT, 600RO
9	212002	2	KEY, 3/16" SQ. x 1"
10	141006	1	MECHANICAL SEAL
11	882012	2	WEAR RING
12	212097	6	VANE, TEFLON
13	212006	1	ROTOR
14	881910	2	O RING, VITON
15	212250	1	HOUSING, 3" 150#
16	151005	1	PIPE PLUG, 1/4"
17	881124	16	LOCKWASHER, 5/16"
18	884088	1	KEY, 3/16" SQ. x 11/16"
19	212015	1	SIDE PLATE
20	212016	1	SPACER, SEAL
21	881269	16	BOLT, 5/16" x 2 1/4"

NO.	REVISION	DATE	BY	APPVD	DRAWING	LEVELS	VIEW
1	WAS QTY 2	01/13/14	SS	X	600ORVR	140, 151, 155, 166,	1
2	WAS #882013	02/18/08	SS	X		196-198, 202, 203	
3	INITIAL RELEASE	10/25/99	SS	X			
					FROM SER#	DATE	TO SER#
					X	X	X

**\*TOLERANCES\***  
ALL DIMENSIONS ARE IN INCHES UNLESS OTHERWISE SPECIFIED.

+TOL. DECIMALS:  
.XXX: +/- .005  
.XX: +/- .015  
.X: +/- .030  
FRAC. = +/- 1/16

\*TOL. ANGLES:  
+/- .5 DEGREES

\*CONCENTRICITY:  
.005 T.I.R.

\*REMOVE BURRS AND BREAK EDGES .005 MIN.

THIS PRINT IS CONFIDENTIAL AND IS THE PROPERTY OF HAMMONDS TECHNICAL SERVICES

THIS PRINT SHALL NOT BE USED, COPIED OR REPRODUCED IN WHOLE OR IN PART NOR SHALL THE CONTENTS BE REVEALED IN ANY MANNER TO WHOME UNLESS WITHIN PERMISSION IS OBTAINED FROM HAMMONDS TECHNICAL SERVICES.

<b>HAMMONDS TECHNICAL SERVICES, INC.</b>	
SCALE: NTS	APPROVED BY: [Signature]
DATE: 10/25/99	REVISION: 01/13/14
DRAWING TITLE: <b>MODEL 600RO DRIVER</b>	
EXPLODED VIEW	DRAWING NUMBER: <b>3829</b>

# Hammonds Model 600RO-1P Injector Manual

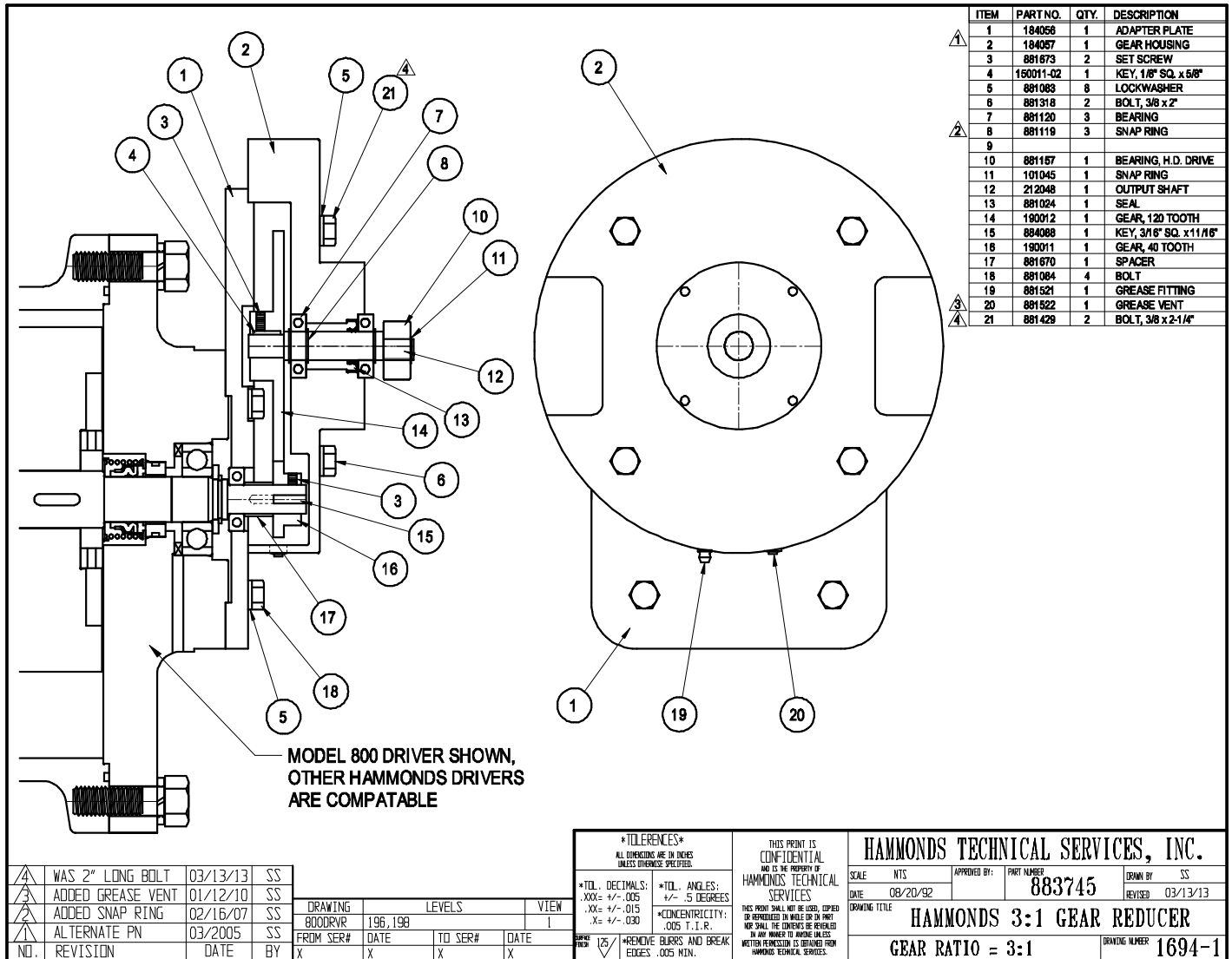

# Hammonds Model 600RO-1P Injector Manual

ITEM	PART NO.	QTY.	DESCRIPTION
1	881121	2	SNAP RING
2	881119	3	SNAP RING
3	881120	1	BEARING, SEALED
4	212016	1	SPACER, SEAL
5	141006	1	MECHANICAL SEAL
6	212015	1	SIDE PLATE, ALUM.
7	881124	16	LOCKWASHER, 5/16"
8	881269	16	BOLT, 5/16" x 2 1/4"
9	212445	1	SHAFT, 600RO-13
10	190009	1	PINION GEAR, 11 TOOTH (13:1 )
	190013	1	PINION GEAR, 14 TOOTH (8.5:1)
11	212002	2	KEY, 3/16" SQ. x 1"
12	882012	2	WEAR RING
13	212097	6	VANE, TEFLON
14	212006	1	ROTOR
15	881910	2	O-RING, VITON
	881154	2	O-RING, BUNA - N ( OPT )
16	212250	1	HOUSING, ALUM, 3" 150#
17	151005	1	PIPE PLUG, 1/4"
18	212272	1	BEARING, SHIELDED
19	212473	1	BACK PLATE, HD

*TOLERANCES*			
ALL DIMENSIONS ARE IN INCHES UNLESS OTHERWISE SPECIFIED.			
*TOL. DECIMALS:	*TOL. ANGLES:	THIS PRINT IS CONFIDENTIAL AND IS THE PROPERTY OF HAMMONDS TECHNICAL SERVICES	
.XX± +/- .005	+/- .5 DEGREES	THIS PRINT SHALL NOT BE LOANED, COPIED OR REPRODUCED IN WHOLE OR IN PART. NEW SHALL. THE CONTENTS BE REVEALED TO ANY PERSON TO WHOM ACCESS IS OBTAINED FROM HAMMONDS TECHNICAL SERVICES.	
.XX± +/- .015			
.X± +/- .030			
FRAC. ± +/- 1/16	*CONCENTRICITY:		
	.005 T. I. R.		
	*REMOVE BURRS AND BREAK EDGES .005 MIN.		

DRAWING	LEVELS	VIEW			
600RR	10-13	1			
NO.	REVISION	DATE	BY	APPVD	
		04/26/07	SS	X	
FROM SER#	DATE	TO SER#	DATE		
X	X	X	X		

HAMMONDS TECHNICAL SERVICES, INC.			
SCALE	APPROVED PART NUMBER		
NTS			
DATE	04/28/07		
DRAWING TITLE			
600RO-13 DRIVER, ALUM.			
8.5:1 or 13:1 RATIOS			DRAWING NUMBER
			5566

# Hammonds Model 600RO-1P Injector Manual

ITEM	PART NO.	QTY.	DESCRIPTION
1	212060	1	ADAPTER PLATE, 8.5:1
2	212059	1	GEAR HOUSING, 8.5:1
3	881673	1	10-24 x 3/16" SET SCREW
4	150011-02	1	KEY, 1/8" SQ. x 5/8"
5	881083	8	3/8" LOCKWASHER
6	881318	2	3/8-16 x 2" HEX BOLT
6A	881429	2	3/8-16 x 2-1/4" HEX BOLT
7	881120	3	BEARING
8	881119	3	SNAP RING
9			
10	881157	1	BEARING, H.D. DRIVE
11	101045	1	SNAP RING
12	212048	1	OUTPUT SHAFT
13	881024	1	SEAL
14	190012	1	GEAR, 120 TOOTH
15	190013	1	PINION GEAR, 14 TOOTH
16	881084	4	3/8-16 x 1" HEX BOLT
17	881521	1	GREASE FITTING

**HAMMONDS MODEL 600ER DRIVER SHOWN**

*TOLERANCES* ALL DIMENSIONS ARE IN INCHES UNLESS OTHERWISE SPECIFIED:		THIS PRINT IS <b>CONFIDENTIAL</b> AND IS THE PROPERTY OF HAMMONDS TECHNICAL SERVICES		<b>HAMMONDS TECHNICAL SERVICES, INC.</b>	
*TOL. DECIMALS: .XXX= +/- .005 .XX= +/- .015 .X= +/- .030 FRAC.= +/- 1/16		*TOL. ANGLES: +/- .5 DEGREES		SCALE: <b>NTS</b>	
*KINCENTRICITY: .005 T. I. R.		*REMOVE BURRS AND BREAK EDGES .005 MIN.		APPROVED PART NUMBER: _____ DRAWN BY: <b>SS</b>	
DATE: 09/21/12		DATE: 03/17/03		REVISIED: 09/21/12	
DRAWING: 1810		LEVELS: 5-8		VIEW: I	
FROM SER# _____ DATE _____		TO SER# _____ DATE _____		DRAWING TITLE: <b>HAMMONDS 8.5:1 GEAR REDUCER</b>	
NO. _____ REVISION _____		APPVD _____		MAT' L: _____ DRAWING NUMBER: <b>4565</b>	

# Hammonds Model 600RO-1P Injector Manual

HAMMONDS  
MODEL 600ER  
DRIVER SHOWN

ITEM	PART NO.	QTY.	DESCRIPTION
1	212047	1	ADAPTER PLATE, 13:1
2	212046	1	GEAR HOUSING, 13:1
3	881673	1	SET SCREW
4		1	KEY, 1/8" SQ. x 5/8"
5	881083	8	LOCKWASHER
6	881318	4	BOLT
7	881120	3	BEARING
8	881119	3	SNAP RING
9			
10	881157	1	BEARING, H.D. DRIVE
11	101045	1	SNAP RING
12	212048	1	OUTPUT SHAFT
13	881024	1	SEAL
14	190010	1	GEAR, 144 TOOTH
15	190009	1	PINION GEAR, 11 TOOTH
16	881084	4	BOLT
17	881521	1	GREASE FITTING

*TOLERANCES*		THIS PRINT IS CONFIDENTIAL AND IS THE PROPERTY OF HAMMONDS TECHNICAL SERVICES		HAMMONDS TECHNICAL SERVICES, INC.	
ALL DIMENSIONS ARE IN INCHES UNLESS OTHERWISE SPECIFIED.		*TOL. DECIMALS:		SCALE <b>NTS</b>	
.XXX= +/- .005		*TOL. ANGLES:		APPROVED PART NUMBER	
.XX= +/- .015		+/- .5 DEGREES		DRAWN BY <b>SSS</b>	
.X= +/- .030		*CONCENTRICITY:		DATE <b>11/26/03</b>	
FRAC. = 1/16		.005 T.I.R.		REVISSED <b>02/16/07</b>	
SURFACE FINISH: 125		*REMOVE BURRS AND BREAK EDGES .005 MIN.		DRAWING TITLE	
				<b>HAMMONDS 13:1 GEAR REDUCER</b>	
				MAT' L:	
				DRAWING NUMBER <b>4782</b>	

# Hammonds Model 600RO-1P Injector Manual

ITEM	PART NO.	QTY.	DESCRIPTION
1	101014	1	POWER FRAME
2	102266	1	PLUNGER, P2
3	102267	1	FLUID END, P2
4	882949	8	LOCK WASHER, #10 INT. TOOTH
5	881780	4	SCREW, 10-32 x 2 3/4"
6	101842	1	CROSSHEAD GUIDE
7	101007	2	RETURN SPRING
8	101006	1	CROSSHEAD
9	101152	2	SLIDE BEARING
10	101005	1	STROKE ADJUSTMENT CAM
11	101003	1	CAM GUIDE
12	101001	1	STROKE ADJUSTMENT KNOB
13	101002	1	POWER FRAME COVER
14	101004	1	LOCK SCREW
15	101009	4	SCREW, 8-32 x 3/8"
16	881086	4	LOCKWASHER, #6
17	101010	4	SCREW, 6-32 x 3/8"
18	881089	4	SCREW, 10-32 x 3/4"
18A	881660	4	SCREW, 10-32 x 2 1/4" (OPTION)
19	102783	2	CHECK VALVE, 1/8", VITON
20	102269	1	O-RING, AFLAS
20A	102270	1	O-RING, VITON (OPTION)
21	102268	1	SEAL HOUSING, P2
22	881024	1	SEAL, LIP
23	881045	1	SETSCREW, 1/4-20 x 1"
24	882911	1	CHECK VALVE, 5 PSI, AFLAS
	101576	1	CHECK VALVE, 5 PSI, VITON (OPTION)
25	101058	1	1/4 x 1/4 FNPT TUBE ADAPT.

WAS #102463	02/20/08	SS	X	DRAWING	LEVELS
WAS #101933	03/15/04	SS	X	INJECTOR	10, 12, 14, 16, 18, 20, 24, 28, 30, 39-41, 89, 90, 202-205
NO.	REVISION	DATE	BY	APPVD	X

<p><b>*TOLERANCES*</b> ALL DIMENSIONS ARE IN INCHES UNLESS OTHERWISE SPECIFIED.</p> <p>*TOL. DECIMALS: .XX= +/- .005 .XX= +/- .015 .X= +/- .030 FRAC. = +/- 1/16</p> <p>*TOL. ANGLES: +/- .5 DEGREES</p> <p>*CONCENTRICITY: .005 T. I.R.</p> <p>REMOVE BURRS AND BREAK EDGES .005 MIN.</p>	<p>THIS PRINT IS CONFIDENTIAL AND IS THE PROPERTY OF HAMMONDS TECHNICAL SERVICES</p> <p>THIS PRINT SHALL NOT BE USED, COPIED OR REPRODUCED IN WHOLE OR IN PART, NOR SHALL THE CONTENTS BE REVEALED IN ANY MANNER TO ANYONE UNLESS WITHIN PERMISSION IS OBTAINED FROM HAMMONDS TECHNICAL SERVICES.</p>	<p style="text-align: center;"><b>HAMMONDS TECHNICAL SERVICES, INC.</b></p> <table style="width: 100%; border: none;"> <tr> <td style="border: none;">SCALE</td> <td style="border: none;">NTS</td> <td style="border: none;">APPROVED PART NUMBER</td> <td style="border: none;">DRAWN BY</td> <td style="border: none;">SSS</td> </tr> <tr> <td style="border: none;">DATE</td> <td style="border: none;">08/20/06</td> <td style="border: none;">REVISOR</td> <td style="border: none;">02/20/08</td> <td style="border: none;">REVISED</td> </tr> </table> <p style="text-align: center; font-weight: bold;">DRAWING TITLE</p> <p style="text-align: center; font-weight: bold;">HAMMONDS 1P2 PUMP</p> <p style="text-align: right;">DRAWING NUMBER <b>4567</b></p>	SCALE	NTS	APPROVED PART NUMBER	DRAWN BY	SSS	DATE	08/20/06	REVISOR	02/20/08	REVISED
SCALE	NTS	APPROVED PART NUMBER	DRAWN BY	SSS								
DATE	08/20/06	REVISOR	02/20/08	REVISED								

# Hammonds Model 600RO-1P Injector Manual

ITEM	PART NO.	QTY.	DESCRIPTION
1	102757	1	POWER FRAME, HD ALUM.
2	881045	1	SETSCREW, 1/4-20 x 1 (PART OF #3)
3	102268	1	PLUNGER, P2
4	881024	1	SEAL, LIP
5			
6	102268	1	SEAL HOUSING, P2
7	102269	1	O-RING, AFLAS
	102270	1	O-RING, VITON (OPTION)
8	102267	1	FLUID END, P2
9	882949	12	LOCK WASHER, #10 INTERNAL
10	881780	4	SCREW, #10-32 x 2 3/4"
11	102783	2	CHECK VALVE, 1/8", VITON
12	101007	2	RETURN SPRING
13	101008	1	CROSSHEAD
14	101152	2	SLIDE BEARING
15	101005	1	STROKE ADJUSTMENT CAM
16	102758	1	PUMP FRAME COVER, HD ALUM
17	101670	1	STROKE INDICATOR
18	101037	2	SCREW, #10-32 x 1 1/2"
19	881126	4	SCREW, #10-32 x 1 1/2"
19A	881126	4	SCREW, #10-32 x 1 1/2" (OPTION)
20	101001	1	STROKE ADJUSTMENT KNOB
21			
22	881301	4	SCREW, #10-32 x 1"
22A	883170	4	SCREW, #10-32 x 2 1/2" (OPT)
23	101038	4	LOCK WASHER, #10 H.C.
24	882911	1	CHECK VALVE, 5 PSI, AFLAS
	101578	1	CHECK VALVE, 5 PSI, VITON (OPT)
25	101058	1	1/4 x 1/4 FNPT TUBE ADAPT.

ITEM	PART NO.	QTY.	DESCRIPTION
26	882352	2	LOCK WASHER, 5/16" SS (OPTION)
27	883863	2	SCREW, 5/16-18 x 1 1/4" SS (OPTION)
27A	882351	2	SCREW, 5/16-18 x 2 3/4" SS (OPTION)
28	102480	2	O-RING (OPTION)
29	102747 A	1	DUST CAP STD. (OPTION)
	102747	1	DUST CAP (FOR OPTIONAL O-RING)
30	101368	1	O-RING (FOR 102747 OPTION)
31	102746	1	DUST PLUG (OPTION)

NO.	REVISION	DATE	BY	APPVD
△	ADDED STD DUST CAP	09/30/16	SS	X
△	INITIAL RELEASE	04/03/09	SS	X
△				

DRAWING	LEVELS	VIEW
INJECTOR	40, 90, 139-141, 143	I
	202, 208, 239, 245	

FROM SER#	DATE	TO SER#	DATE
X	X	X	X

*TOLERANCES*	*TOL. ANGLES*	*CENTRICITY*
ALL DIMENSIONS ARE IN INCHES UNLESS OTHERWISE SPECIFIED.	+/- .005	+/- .005 T. I. R.
.XX = +/- .015	+/- .5 DEGREES	
.X = +/- .030		
FRAC. = +/- 1/16		

  

THIS PRINT IS CONFIDENTIAL AND IS THE PROPERTY OF HAMMONDS TECHNICAL SERVICES	SCALE	APPROVED PART NUMBER	DRAWN BY
THIS PRINT SHALL NOT BE USED, COPIED OR REPRODUCED IN WHOLE OR IN PART UNLESS THE CONTENTS BE REVEALED BY ANY PRINTING OR MARKING UNLESS WITHIN PERMISSION IS OBTAINED FROM HAMMONDS TECHNICAL SERVICES.	NTS		SS
	DATE 04/03/09		REVISED 08/30/16

DRAWING TITLE	DRAWING NUMBER
HAMMONDS 1P2 PUMP	6120
HEAVY DUTY	

# Hammonds Model 600RO-1P Injector Manual

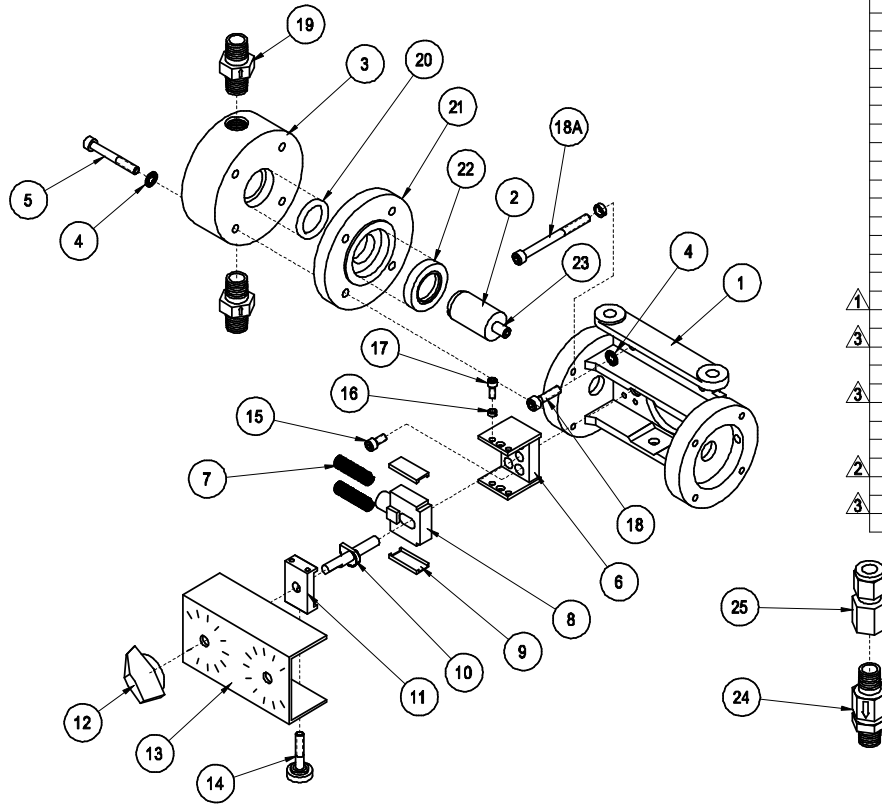

ITEM	PART NO.	QTY.	DESCRIPTION
1	101014	1	POWER FRAME
2	102339	1	PLUNGER, P5
3	102340	1	FLUID END, P5
4	882949	8	LOCK WASHER, #10 INT. TOOTH
5	881317	4	SCREW, 10-32 x 2"
6	101842	1	CROSSHEAD GUIDE
7	101007	2	RETURN SPRING
8	101006	1	CROSSHEAD
9	101152	2	SLIDE BEARING
10	101005	1	STROKE ADJUSTMENT CAM
11	101003	1	CAM GUIDE
12	101001	1	STROKE ADJUSTMENT KNOB
13	101002	1	POWER FRAME COVER
14	101004	1	LOCK SCREW
15	101009	4	SCREW, 8-32 x 3/8"
16	881086	4	LOCKWASHER, #8
17	101010	4	SCREW, 6-32 x 3/8"
18	881089	4	SCREW, 10-32 x 3/4"
18A	881660	4	SCREW, 10-32 x 2 1/4" (OPTION)
▲	19	102463	CHECK VALVE, AFLAS, STD.
▲		102464	CHECK VALVE, VITON (OPTION)
▲		102642	CHECK VALVE, KALREZ (OPTION)
▲	20	101856	O-RING, AFLAS
▲		101857	O-RING, VITON (OPTION)
▲		103814	O-RING, KALREZ (OPTION)
▲	21	102341	SEAL HOUSING, P5
▲	22	881079	SEAL, LIP
▲	23	881045	SETScrew, 1/4-20 x 1" (PART OF #2)
▲	24	882911	CHECK VALVE, 5 PSI, AFLAS
▲		101578	CHECK VALVE, 5 PSI, VITON (OPT)
▲		102643	CHECK VALVE, 5 PSI, KALREZ (OPT)
▲	25	101088	3/8 x 1/4 FNPT TUBE ADAPT.

*TOLERANCES* ALL DIMENSIONS ARE IN INCHES UNLESS OTHERWISE SPECIFIED.				THIS PRINT IS CONFIDENTIAL AND IS THE PROPERTY OF HAMMONDS TECHNICAL SERVICES		HAMMONDS TECHNICAL SERVICES, INC.	
*TOL. DECIMALS: .XX± 1/1000 .XX± 1/100 .X± 1/100 FRAC. = 1/16		*TOL. ANGLES: ± .5 DEGREES		*CONCENTRICITY: .005 T.I.R.		SCALE: NTS DATE: 10/07/99 DRAWING TITLE: HAMMONDS 1P5 PUMP	
*REMOVE BURRS AND BREAK EDGES .005 MIN.		THIS PRINT SHALL NOT BE USED, COPIED OR REPRODUCED IN WHOLE OR IN PART FOR SHALL THE COMPANY BE LIABLE IN ANY MANNER TO ANYONE UNLESS WITHIN PERMISSION IS OBTAINED FROM HAMMONDS TECHNICAL SERVICES.		APPROVED PART NUMBER: . DRAWN BY: SSS REVISED: 06/25/09		DRIVING NUMBER: 3836	
NO. REVISION		DATE		BY		APVD	
▲ ADDED KALREZ OPT		06/25/09		SS		DRAWING LEVELS	
▲ WAS #101671		03/15/04		SS		INJECTOR 10, 12, 14, 16, 18, 20, 24, 28, 30	
▲ WAS #101933		03/15/04		SS		39-41, 89-93, 95-97, 99, 118, 119	
				FROM SER#		DATE	
				TO SER#		DATE	

# Hammonds Model 600RO-1P Injector Manual

26	882352	2	LOCK WASHER, 5/16" SS (OPTION)
27	883863	2	SCREW, 5/16-18 x 1 1/4" SS (OPTION)
27A	882351	2	SCREW, 5/16-18 x 2 3/4" SS (OPTION)
28	102480	2	O-RING (OPTION)
29	102747A	1	DUST CAP STD. (OPTION)
	102747	1	DUST CAP (FOR OPTIONAL O-RING)
30	101368	1	O-RING (FOR 102747 OPTION)
31	102746	1	DUST PLUG (OPTION)

ITEM	PART NO.	QTY.	DESCRIPTION
1	102757	1	POWER FRAME, HD ALUM.
2	881045	1	SETSCREW, 1/4-20 x 1 (PART OF #3)
3	102339	1	PLUNGER, P5
4	881079	1	SEAL LIP
5			
6	102341	1	SEAL HOUSING, P5
7	101856	1	O-RING, AFLAS
	101857	1	O-RING, VITON (OPTION)
	103514	1	O-RING, KALREZ (OPTION)
8	102340	1	FLUID END, P5
9	882949	12	LOCK WASHER, #10 INTERNAL
10	881317	4	SCREW, #10-32 x 2"
11	102463	2	CHECK VALVE, 1 PSI, AFLAS
	102464	2	CHECK VALVE, 1 PSI, VITON (OPT)
	102642	2	CHECK VALVE, 1 PSI, KALREZ (OPT)
12	101007	2	RETURN SPRING
13	101008	1	CROSS-HEAD
14	101152	2	SLIDE BEARING
15	101005	1	STROKE ADJUSTMENT CAM
16	102758	1	PUMP FRAME COVER, HD ALUM
17	101670	1	STROKE INDICATOR
18	101037	2	SCREW, #10-32 x 1 1/2"
19	881128	4	SCREW, #10-32 x 1/2"
19A	881128	4	SCREW, #10-32 x 1/2" (OPTION)
20	101001	1	STROKE ADJUSTMENT KNOB
21			
22	881301	4	SCREW, #10-32 x 1"
22A	883170	4	SCREW, #10-32 x 2 1/2" (OPT)
23	101038	4	LOCK WASHER, #10 H.C.
24	882911	1	CHECK VALVE, 5 PSI, AFLAS
	101576	1	CHECK VALVE, 5 PSI, VITON (OPT)
	102643	1	CHECK VALVE, 5 PSI, KALREZ (OPT)
25	101088	1	3/8 x 1/4 FNPT TUBE ADAPT.

NO.	REVISION	DATE	BY	APPVD	X
△	ADDED STD DUST CAP	09/30/16	SS	X	
△	ADDED KALREZ OPT	06/25/09	SS	X	
△	INITIAL RELEASE	10/27/08	SS	X	

DRAWING		LEVELS	
INJECTOR	40, 90-98, 129, 139-141, 143		
	208, 239		
FROM SER#	DATE	TO SER#	DATE
X	X	X	X

*TOLERANCES*		THIS PRINT IS	
ALL DIMENSIONS ARE IN INCHES		CONFIDENTIAL	
UNLESS OTHERWISE SPECIFIED.		AND IS THE PROPERTY OF	
		HAMMONDS TECHNICAL	
		SERVICES	
		SERVICES	
		DATE 10/27/08	
		DRAWING TITLE	
		HAMMONDS 1P5 PUMP	
		HEAVY DUTY	
		DRAWING NUMBER 5993	

\*TOLERANCES\*  
ALL DIMENSIONS ARE IN INCHES  
UNLESS OTHERWISE SPECIFIED.

\*TOL. DECIMALS:  
.XX± +/- .005  
.XX± +/- .015  
.X± +/- .030  
FRAC. ± 1/16

\*TOL. ANGLES:  
+/- .5 DEGREES

\*CONCENTRICITY:  
.005 I. I. R.

REMOVE BURRS AND BREAK  
EDGES .005 MIN.

DO NOT SCALE. NOT BE USED, COPIED  
OR REPRODUCED IN ANY MANNER OR BY ANY  
MEANS. THE CONTENTS BE REVEALED  
TO ANY OTHER PARTY WITHOUT  
WRITTEN PERMISSION IS OBTAINED FROM  
HAMMONDS TECHNICAL SERVICES.

# Hammonds Model 600RO-1P Injector Manual

ITEM	PART NO.	QTY.	DESCRIPTION
1	101014	1	POWER FRAME
2	102137	1	PLUNGER, P6
3	102138	1	FLUID END, P6
4	882849	8	LOCK WASHER, #10 INT. TOOTH
5	881317	4	SCREW, 10-32 x 2"
6	101842	1	CROSSHEAD GUIDE
7	101007	2	RETURN SPRING
8	101006	1	CROSSHEAD
9	101152	2	SLIDE BEARING
10	101005	1	STROKE ADJUSTMENT CAM
11	101003	1	CAM GUIDE
12	101001	1	STROKE ADJUSTMENT KNOB
13	101002	1	POWER FRAME COVER
14	101004	1	LOCK SCREW
15	101009	4	SCREW, 8-32 x 3/8"
16	881086	4	LOCKWASHER, #6
17	101010	4	SCREW, 6-32 x 3/8"
18	881089	4	SCREW, 10-32 x 3/4"
18A	881860	4	SCREW, 10-32 x 2 1/4" (OPTION)
19	102463	2	CHECK VALVE, AFLAS, STD.
	102464	2	CHECK VALVE, VITON (OPT)
	102642	2	CHECK VALVE, KALREZ (OPT)
20	101491	1	O-RING, AFLAS
	101417	1	O-RING, VITON (OPTION)
	103644	1	O-RING, KALREZ (OPTION)
21	102139	1	SEAL HOUSING
22	881024	1	SEAL, LIP
23	881045	1	SETScrew, 1/4-20 x 1"
24	882911	1	CHECK VALVE, 5 PSI, AFLAS, STD.
	101578	1	CHECK VALVE, 5 PSI, VITON, (OPT)
	102643	1	CHECK VALVE, 5 PSI, KALREZ, (OPT)
25	101088	1	3/8 x 1/4 FNPT TUBE ADAPT.

*TOLERANCES*		*TOL. ANGLES*		*CONCENTRICITY*	
ALL DIMENSIONS ARE IN INCHES UNLESS OTHERWISE SPECIFIED.		ALL DIMENSIONS ARE IN DEGREES UNLESS OTHERWISE SPECIFIED.		ALL DIMENSIONS ARE IN INCHES UNLESS OTHERWISE SPECIFIED.	
*TOL. DECIMALS:	XX: +/- .005	*TOL. ANGLES:	1/2° +/- .5 DEGREES	*CONCENTRICITY:	.005 T. I. R.
	.XX: +/- .015				
	.X: +/- .030				
REMOVE BURRS AND BREAK EDGES .005 MIN.		THIS PRINT IS CONFIDENTIAL AND IS THE PROPERTY OF HAMMONDS TECHNICAL SERVICES. THIS PRINT SHALL NOT BE USED, COPIED OR REPRODUCED IN WHOLE OR IN PART AND SHALL BE RETURNED TO OR DESTROYED IN ANY MANNER TO AVOID UNLESS WRITTEN PERMISSION IS OBTAINED FROM HAMMONDS TECHNICAL SERVICES.			

KALREZ OPTION		07/13/21	SS	DRAWING INJECTOR		LEVELS 10, 12, 14, 16, 18, 20, 24, 26, 30		VIEW 7
NEW CHECK VALVES		03/15/04	SS	FROM SER#		DATE		TO SER#
WAS #102263		09/03/02	SS	DATE		DATE		DATE
NO.	REVISION	DATE	BY	X	X	X	X	X

HAMMONDS TECHNICAL SERVICES, INC.	
SCALE: NTS	APPROVED BY: _____
DATE: 09/22/92	DESIGNED BY: SS
DRAWING TITLE: <b>HAMMONDS 1P6 PUMP</b>	
DRAWING NUMBER: <b>1687</b>	

# Hammonds Model 600RO-1P Injector Manual

ITEM	PART NO.	QTY.	DESCRIPTION
1	102757	1	POWER FRAME, HD ALUM.
2	881045	1	SETSCREW, 1/4-20 x 1 (PART OF #3)
3	102137	1	PLUNGER, P6
4	881024	1	SEAL, LIP
5			
6	102139	1	SEAL HOUSING, P6
7	101491	1	O-RING, AFLAS
	101417	1	O-RING, VITON (OPTION)
	103544	1	O-RING, KALREZ (OPTION)
8	102138	1	FLUID END, P6
9	882949	12	LOCK WASHER, #10 INTERNAL
10	881317	4	SCREW, #10-32 x 2"
11	102463	2	CHECK VALVE, 1 PSI, AFLAS
	102464	2	CHECK VALVE, 1 PSI, VITON (OPT)
	102642	2	CHECK VALVE, 1 PSI, KALREZ (OPT)
12	101007	2	RETURN SPRING
13	101006	1	CROSSHEAD
14	101152	2	SLIDE BEARING
15	101005	1	STROKE ADJUSTMENT CAM
16	102758	1	PUMP FRAME COVER, HD ALUM
17	101670	1	STROKE INDICATOR
18	101037	2	SCREW, #10-32 x 1 1/2"
19	881126	4	SCREW, #10-32 x 1 1/2"
19A	881126	4	SCREW, #10-32 x 1 1/2" (OPTION)
20	101001	1	STROKE ADJUSTMENT KNOB
21			
22	881301	4	SCREW, #10-32 x 1"
22A	883170	4	SCREW, #10-32 x 2 1/2" (OPT)
23	101038	4	LOCK WASHER, #10 H.C.
24	882911	1	CHECK VALVE, 5 PSI, AFLAS
	101576	1	CHECK VALVE, 5 PSI, VITON (OPT)
	102643	1	CHECK VALVE, 5 PSI, KALREZ (OPT)
25	101088	1	3/8 x 1/4 FNPT TUBE ADAPT.

ITEM	PART NO.	QTY.	DESCRIPTION
26	882352	2	LOCK WASHER, 5/16" SS (OPTION)
27	883863	2	SCREW, 5/16-18 x 1 1/4" SS (OPTION)
27A	882351	2	SCREW, 5/16-18 x 2 3/4" SS (OPTION)
28	102480	2	O-RING (OPTION)
29	102747A	1	DUST CAP STD. (OPTION)
	102747	1	DUST CAP (FOR OPTIONAL O-RING)
30	101368	1	O-RING (FOR 102747 OPTION)
31	102746	1	DUST PLUG (OPTION)

NO.	REVISION	DATE	BY	APPROV	DRAWING	LEVELS	VIEW
△	ADDED STD DUST CAP	09/30/16	SS	X	DRAWING	LEVELS	VIEW
△	ADDED KALREZ OPT	09/20/16	SS	X	INJECTOR	40, 90-93, 95-97, 129, 1	
△	INITIAL RELEASE	10/27/08	SS	X		139-141, 143, 208, 239, 249	
					FROM SER#	DATE	TO SER#
							DATE

**\*TOLERANCES\***  
ALL DIMENSIONS ARE IN INCHES UNLESS OTHERWISE SPECIFIED.

\*TOL. DECIMALS:  
.XX± .005  
.XX± .015  
.X± .030  
FRAC. ± 1/16

\*TOL. ANGLES:  
± .5 DEGREES

\*CONCENTRICITY:  
.005 T. I. R.

\*REMOVE BURRS AND BREAK EDGES .005 MIN.

THIS PRINT IS CONFIDENTIAL AND IS THE PROPERTY OF HAMMONDS TECHNICAL SERVICES

THIS PRINT SHALL NOT BE USED, COPIED OR REPRODUCED IN WHOLE OR IN PART WITHOUT THE WRITTEN PERMISSION OF HAMMONDS TECHNICAL SERVICES.

<b>HAMMONDS TECHNICAL SERVICES, INC.</b>			
SCALE: NTS	APPROVED PART NUMBER:	DRAWN BY: SS	
DATE: 10/27/08		REVISED: 09/30/16	
DRAWING TITLE: <b>HAMMONDS 1P6 PUMP</b>			
HEAVY DUTY			DRAWING NUMBER: <b>6017</b>

# Hammonds Model 600RO-1P Injector Manual

ITEM	PARTNO.	QTY.	DESCRIPTION
1	101014	1	POWER FRAME
2	102192	1	PLUNGER, P7
3	102193	1	FLUID END, P7
4	882849	8	LOCK WASHER, #10 INT. TOOTH
5	881317	4	SCREW, 10-32 x 2"
6	101842	1	CROSSHEAD GUIDE
7	101007	2	RETURN SPRING
8	101006	1	CROSSHEAD
9	101152	2	SLIDE BEARING
10	101005	1	STROKE ADJUSTMENT CAM
11	101003	1	CAM GUIDE
12	101001	1	STROKE ADJUSTMENT KNOB
13	101002	1	POWER FRAME COVER
14	101004	1	LOCK SCREW
15	101009	4	SCREW, 8-32 x 3/8"
16	881086	4	LOCKWASHER, #6
17	101010	4	SCREW, 6-32 x 3/8"
18	881089	4	SCREW, 10-32 x 3/4"
18A	881680	4	SCREW, 10-32 x 2 1/4" (OPTION)
19	102463	2	CHECK VALVE, AFLAS
	102464	2	CHECK VALVE, VITON (OPTION)
6	102642	2	CHECK VALVE, KALREZ (OPTION)
20	101490	1	O-RING, AFLAS
	101226	1	O-RING, VITON (OPTION)
6	101754	1	O-RING, KALREZ (OPTION)
21	102194	1	SEAL HOUSING
22	881785	1	SEAL, LIP
23	881045	1	SETSCREW, 1/4-20 x 1"
5	882911	1	CHECK VALVE, 5 PSI, AFLAS, STD.
6	101576	1	CHECK VALVE, 5 PSI, VITON, (OPT)
	102643	1	CHECK VALVE, 5 PSI, KALREZ, (OPT)
25	101088	1	3/8 x 1/4 FNPT TUBE ADAPT.

NO.	REVISION	DATE	BY	FROM SER#	DATE	TO SER#	DATE
△	ADDED PART NOS.	01/21/14	SS				
△	WAS #101671	03/15/04	SS				
△	WAS #101933	03/15/04	SS				
△	WAS #102263	09/03/02	SS				
△	WAS #101008	08/99	SS				
△	ADDED INJ CHK VLV	01/06/98	SS				

DRAWING	LEVELS	VIEW
INJECTOR	10, 12, 14, 16, 19, 20, 24, 28, 30	1
	39-41, 89-93, 95-97, 99, 110, 111	

*TOLERANCES*	THIS PRINT IS	HAMMONDS TECHNICAL SERVICES, INC.
ALL DIMENSIONS ARE IN INCHES UNLESS OTHERWISE SPECIFIED.	CONFIDENTIAL	SCALE: NTS
*TOL. DECIMALS:	HAMMONDS TECHNICAL SERVICES	APPROVED PART NUMBER
.XX = +/- .005		DRAWN BY: SS
.XX = +/- .015		DATE: 05/11/93
.X = +/- .030		REVISED: 01/21/14
FRAC. = +/- 1/16		DRAWING TITLE: HAMMONDS 1P7 PUMP ASSEMBLY
*TOL. ANGLES:		DRAWING NUMBER: 1911
+/- 5 DEGREES		
*CONCENTRICITY:		
.005 T. I. R.		
*REMOVE BURRS AND BREAK EDGES .005 MIN.		

# Hammonds Model 600RO-1P Injector Manual

26	882352	2	LOCK WASHER, 5/16" SS (OPTION)
27	883863	2	SCREW, 5/16-18 x 1 1/4" SS (OPTION)
27A	882351	2	SCREW, 5/16-18 x 2 3/4" SS (OPTION)
28	102480	2	O-RING (OPTION)
29	102747A	1	DUST CAP STD. (OPTION)
	102747	1	DUST CAP (FOR OPTIONAL O-RING)
30	101388	1	O-RING (FOR 102747 OPTION)
31	102746	1	DUST PLUG (OPTION)

ITEM	PART NO.	QTY.	DESCRIPTION
1	102757	1	POWER FRAME, HD ALUM.
2	881045	1	SETSCREW, 1/4-20 x 1 (PART OF #3)
3	102192	1	PLUNGER, P7
4	881765	1	SEAL, LIP
5	101749	1	1/8" FILTER (OPTION)
6	102194	1	SEAL HOUSING
6A	102474	1	SEAL HOUSING, VENTED (OPTION)
7	101490	1	O-RING, AFLAS
	101226	1	O-RING, VITON (OPTION)
	101754	1	O-RING, KALREZ (OPTION)
8	102193	1	FLUID END, P7
9	882949	12	LOCK WASHER, #10 INTERNAL
10	881317	4	SCREW, #10-32 x 2"
11	102463	2	CHECK VALVE, AFLAS
	102464	2	CHECK VALVE, VITON (OPTION)
	102642	2	CHECK VALVE, KALREZ (OPTION)
12	101007	2	RETURN SPRING
13	101006	1	CROSSHEAD
14	101152	2	SLIDE BEARING
15	101005	1	STROKE ADJUSTMENT CAM
16	102758	1	PUMP FRAME COVER, HD ALUM
17	101670	1	STROKE INDICATOR
18	101037	2	SCREW, #10-32 x 1 1/2"
19	881126	4	SCREW, #10-32 x 1/2"
19A	881126	4	SCREW, #10-32 x 1/2" (OPTION)
20	101001	1	STROKE ADJUSTMENT KNOB
21	101749	1	1/8" FILTER (OPTION)
22	881301	4	SCREW, #10-32 x 1"
22A	883170	4	SCREW, #10-32 x 2 1/2" (OPT)
23	101038	4	LOCK WASHER, #10 H.C.
24	882911	1	CHECK VALVE, 5 PSI, AFLAS
	101576	1	CHECK VALVE, 5 PSI, VITON (OPT)
	102643	1	CHECK VALVE, 5 PSI, KALREZ (OPT)
25	101088	1	3/8 x 1/4 FNPT TUBE ADAPT.

*TOLERANCES*	
ALL DIMENSIONS ARE IN INCHES UNLESS OTHERWISE SPECIFIED.	
*TOL. DECIMALS:	*TOL. ANGLES:
.XX± +/- .005	+/- .5 DEGREES
.XX± +/- .015	
.X± +/- .030	*CONCENTRICITY:
FRACTION ± +/- 1/16	.005 T. I. R.
FINISH 25	*REMOVE BURRS AND BREAK EDGES .005 MIN.

THIS PRINT IS CONFIDENTIAL AND IS THE PROPERTY OF HAMMONDS TECHNICAL SERVICES	
SCALE NTS	APPROVED PART NUMBER
DATE 02/16/07	REVISED 09/30/16
DRAWING TITLE	
HAMMONDS 1P7 PUMP	
HEAVY DUTY	DRAWING NUMBER 5550

DRAWING LEVELS			
INJECTOR	40, 90-93, 95-97, 129, 139-141		
	143, 208, 210, 239, 242, 243		
FROM SER#	DATE	TO SER#	DATE
X	X	X	X

ADDED STD DUST CAP	09/30/16	SS	X
INITIAL RELEASE	02/16/07	SS	X
NO. REVISION	DATE	BY	APPVD

# Hammonds Model 600RO-1P Injector Manual

ITEM	PART NO.	QTY.	DESCRIPTION
1	101014	1	POWER FRAME
2	102224	1	PLUNGER, P10
3	102225	1	FLUID END, P10
4	882949	8	LOCK WASHER, #10 INT. TOOTH
5	881317	4	SCREW, 10-32 x 2"
6	101842	1	CROSSHEAD GUIDE
7	101007	2	RETURN SPRING
8	101006	1	CROSSHEAD
9	101152	2	SLIDE BEARING
10	101005	1	STROKE ADJUSTMENT CAM
11	101003	1	CAM GUIDE
12	101001	1	STROKE ADJUSTMENT KNOB
13	101002	1	POWER FRAME COVER
14	101004	1	LOCK SCREW
15	101009	4	SCREW, 8-32 x 3/8"
16	881086	4	LOCKWASHER, #6
17	101010	4	SCREW, 6-32 x 3/8"
18	881089	4	SCREW, 10-32 x 3/4"
18A	881660	4	SCREW, 10-32 x 2 1/4" (OPTION)
19	102463	2	CHECK VALVE, AFLAS, STD.
	102464	2	CHECK VALVE, VITON, (OPTION)
20	101537	1	O-RING, AFLAS
	101836	1	O-RING, VITON (OPTION)
	101883	1	O-RING, EPDM (OPTION)
21	102226	1	SEAL HOUSING
22	881908	1	SEAL, LIP
23	881045	1	SETScrew, 1/4-20 x 1"
24	882911	1	CHECK VALVE, 5 PSI, AFLAS, STD.
	101576	1	CHECK VALVE, 5 PSI, VITON (OPT)
25	101088	1	3/8 x 1/4 FNPT TUBE ADAPT.

NO.	REVISION	DATE	BY	APPVD
△	WAS #101671	03/15/04	SS	X
△	WAS #101933	03/15/04	SS	X
△	WAS #102263	09/03/02	SS	X
△	WAS #101008	08/99	SS	X

DRAWING	LEVELS		
INJECTOR	10, 12, 14, 16, 18, 20, 24, 28, 30		
	39-41, 89-93, 95-97, 99, 116, 117		
FROM SER#	DATE	TO SER#	DATE
X	X	X	X

*TOLERANCES* ALL DIMENSIONS ARE IN INCHES UNLESS OTHERWISE SPECIFIED.		THIS PRINT IS CONFIDENTIAL AND IS THE PROPERTY OF HAMMONDS TECHNICAL SERVICES	
*TOL. DECIMALS: .XX± +/- .005 .XX± +/- .015 .X± +/- .030 FRAC. ± +/- 1/16	*TOL. ANGLES: +/- .5 DEGREES	THIS PRINT SHALL NOT BE USED, COPIED OR REPRODUCED IN WHOLE OR IN PART NOR SHALL THE CONTENTS BE REVEALED IN ANY MANNER TO WHOMEVER WITHOUT PERMISSION IS RECEIVED FROM HAMMONDS TECHNICAL SERVICES.	
*CONCENTRICITY: .005 T. I. R.		*REMOVE BURRS AND BREAK EDGES .005 MIN.	

<b>HAMMONDS TECHNICAL SERVICES, INC.</b>			
SCALE: NTS	APPROVED PART NUMBER:	DRAWN BY: SSS	
DATE: 09/23/93		REVISED: 03/15/04	
DRAWING TITLE: <b>HAMMONDS 1P10 PUMP</b>			
			DRAWING NUMBER: <b>2668</b>

# Hammonds Model 600RO-1P Injector Manual

26	882352	2	LOCK WASHER, 5/16" SS (OPTION)
27	883863	2	SCREW, 5/16-18 x 1 1/4" SS (OPTION)
27A	882351	2	SCREW, 5/16-18 x 2 3/4" SS (OPTION)
28	102480	2	O-RING (OPTION)
29	102747A	1	DUST CAP STD. (OPTION)
	102747	1	DUST CAP (FOR OPTIONAL O-RING)
30	101368	1	O-RING (FOR 102747 OPTION)
31	102746	1	DUST PLUG (OPTION)

ITEM	PART NO.	QTY.	DESCRIPTION
1	102757	1	POWER FRAME, HD ALUM.
2	881045	1	SETSCREW, 1/4-20 x 1 (PART OF #3)
3	102224	1	PLUNGER, P10
4	881908	1	SEAL, LIP
5			
6	102226	1	SEAL HOUSING
7	101537	1	O-RING, AFLAS
	101839	1	O-RING, VITON (OPTION)
	103619	1	O-RING, KALREZ (OPTION)
8	102225	1	FLUID END, P10
9	882949	12	LOCK WASHER, #10 INTERNAL
10	881317	4	SCREW, #10-32 x 2"
11	102463	2	CHECK VALVE, 1 PSI, AFLAS
	102464	2	CHECK VALVE, 1 PSI, VITON (OPT)
	102642	2	CHECK VALVE, 1 PSI, KALREZ (OPT)
12	101007	2	RETURN SPRING
13	101006	1	CROSSHEAD
14	101152	2	SLIDE BEARING
15	101005	1	STROKE ADJUSTMENT CAM
16	102758	1	PUMP FRAME COVER, HD ALUM
17	101670	1	STROKE INDICATOR
18	101037	2	SCREW, #10-32 x 1 1/2"
19	881126	4	SCREW, #10-32 x 1 1/2"
19A	881126	4	SCREW, #10-32 x 1 1/2" (OPTION)
20	101001	1	STROKE ADJUSTMENT KNOB
21			
22	881301	4	SCREW, #10-32 x 1"
22A	883170	4	SCREW, #10-32 x 2 1/2" (OPT)
23	101038	4	LOCK WASHER, #10 H.C.
24	882911	1	CHECK VALVE, 5 PSI, AFLAS
	101576	1	CHECK VALVE, 5 PSI, VITON (OPT)
	102643	1	CHECK VALVE, 5 PSI, KALREZ (OPT)
25	101088	1	3/8 x 1/4 FNPT TUBE ADAPT.

NO.	REVISION	DATE	BY	APPVD	FROM SER#	DATE	TO SER#	DATE	VIEW
△	ADDED STD DUST CAP	09/30/16	SS	X					I
△	ADDED KALREZ OPT	09/20/16	SS	X					I
△	INITIAL RELEASE	06/05/09	SS	X					I

*TOLERANCES*		THIS PRINT IS CONFIDENTIAL AND IS THE PROPERTY OF HAMMONDS TECHNICAL SERVICES		HAMMONDS TECHNICAL SERVICES, INC.	
ALL DIMENSIONS ARE IN INCHES UNLESS OTHERWISE SPECIFIED.		DRAWING LEVELS		SCALE NTS	
*TOL. DECIMALS:	.XX± .005	INJECTOR		APPROVED PART NUMBER	
.XX± .015	.XX± .015	40_90-93_95-97_129_1		DRAWN BY SS	
.X± .030	.X± .030	139-141, 143, 208, 239, 253		DATE 06/05/09	
FRAC. ± 1/16	FRAC. ± 1/16	FROM SER# DATE TO SER# DATE		REVISY 09/30/16	
REMOVE BURRS AND BREAK EDGES .005 MIN.	*CONCENTRICITY: .005 T. I. R.	DRAWING TITLE		HEAVY DUTY	
		HAMMONDS 1P10 PUMP		DRAWING NUMBER 6150-1	

# Hammonds Model 600RO-1P Injector Manual

ITEM	PART NO.	QTY.	DESCRIPTION
1	152074	1	CAP, ASS'Y.
2	152075	1	BODY, ASS'Y.
* 3	151002	2	O-RING, BUNA-N
4	151001	1	GLASS
5	152002	1	FILTER ELEMENT
6	151005	1	PIPE PLUG, 1/4"
<b>OPTIONAL:</b>			
* 3	151007	2	O-RING, VITON
* 3	151027	2	O-RING, NEOPRENE
7	102787	1	1/4" CHK VLV, 5 PSI, AFLAS
7	881715	1	1/4" CHK VLV, 5 PSI, VITON

  

	ADDED VITON C/V	05/23/14	SS		
	ADDED CHECK VALVE	05/23/14	SS		
	INITIAL RELEASE	07/23/84	SS		
NO.	REVISION	DATE	BY	FROM SER#	TO SER#
				X	X

<b>*TOLERANCES*</b> ALL DIMENSIONS ARE IN INCHES UNLESS OTHERWISE SPECIFIED.	THIS PRINT IS CONFIDENTIAL AND IS THE PROPERTY OF HAMMONDS TECHNICAL SERVICES	<b>HAMMONDS TECHNICAL SERVICES, INC.</b>
*TOL. DECIMALS: .XX± ±/-.005 .XX± ±/-.015 .X± ±/-.030	*TOL. ANGLES: ±/-.5 DEGREES *CONCENTRICITY: .005 T.I.R.	SCALE: NTS DATE: 07/23/84 APPROVED BY: 152011 DRAWN BY: SS REVISOR: 05/23/14
REMOVE BURRS AND BREAK EDGES .005 MIN.	THIS PRINT SHALL NOT BE REPRODUCED OR REPRODUCED IN WHOLE OR IN PART NOR SHALL THE CONTENTS BE REVEALED IN ANY MANNER TO ANY PERSON WITHOUT PERMISSION AS OBTAINED FROM HAMMONDS TECHNICAL SERVICES.	DRAWING TITLE: <b>SIGHT FLOW INDICATOR, STD.</b> DRAWING NUMBER: <b>0159</b>

# Hammonds Model 600RO-1P Injector Manual

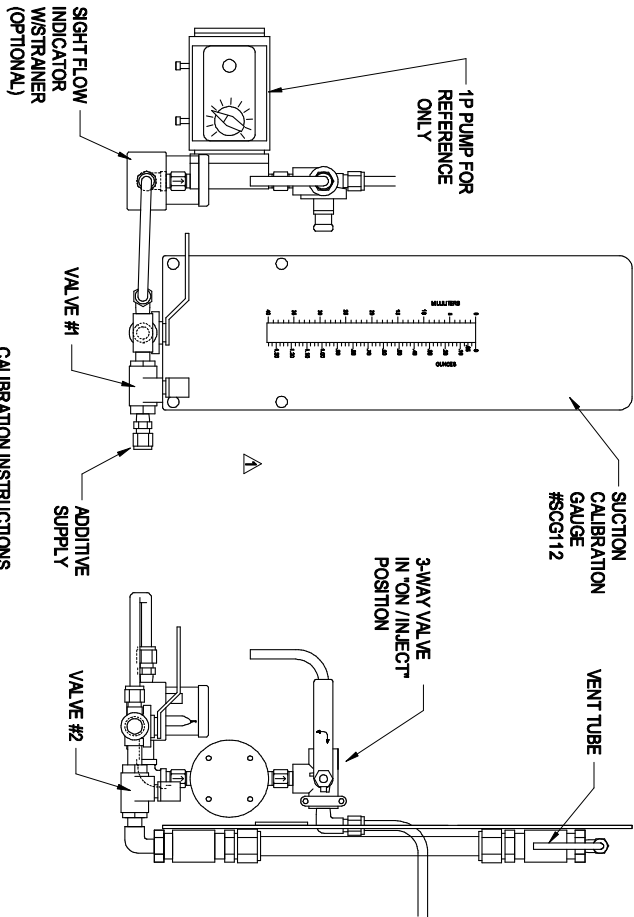

### CALIBRATION INSTRUCTIONS

- 1) IN ORDER TO CALIBRATE, THE MAIN PRODUCT SHOULD BE FLOWING.
- 2) WITH 3-WAY VALVE AND VALVE #1 IN NORMAL OPERATION "ON" AND SYSTEM OPERATING, TURN VALVE #2 ON. THIS WILL FILL CALIBRATION TUBE. FILL TO ZERO MARK. DO NOT OVERFILL. ONCE FULL, TURN VALVE #2 OFF.
- 3) MAKE NOTE OF ADDITIVE LEVEL IN CALIBRATION TUBE AND MAIN PRODUCT METER READING. BEGIN CALIBRATION BY FIRST TURNING VALVE #1 "OFF" AND VALVE #2 "ON".
- 4) ONCE CALIBRATION TUBE IS NEAR THE BOTTOM, STOP TEST BY FIRST TURNING VALVE #2 "OFF" AND VALVE #1 "ON". AT THE SAME TIME MARKING NOTE OF THE MAIN PRODUCT METER READING.
- 5) COMPARE TOTAL AMOUNT OF ADDITIVE INJECTED FROM CALIBRATION TUBE TO AMOUNT OF FUEL DELIVERED DURING DURATION OF TEST.
- 6) INCREASE OR DECREASE PERCENTAGE OF STROKE ON DIAPHRAGM PUMP. REPEAT TEST UNTIL DESIRED INJECTION RATIO IS ACHIEVED.

EXAMPLE:  
 ADDITIVE INJECTED = 7.0 ML  
 FUEL DELIVERED = 350 LITERS

7.0 = .020  
 350  
 .020 = .000020 (20 MILLIONTHS)  
 1000

OR 20 PPM (PARTS PER MILLION)

*TOLERANCES* ALL DIMENSIONS UNLESS SPECIFIED FRACTIONS: 1/16, 1/8, 3/16, 1/2, 5/8 DECIMALS: .1, .2, .3, .4, .5, .6, .7, .8, .9, .01, .02, .03, .04, .05, .06, .07, .08, .09, .10, .15, .20, .25, .30, .35, .40, .45, .50, .55, .60, .65, .70, .75, .80, .85, .90, .95, .001, .002, .003, .004, .005, .006, .007, .008, .009, .010, .015, .020, .025, .030, .035, .040, .045, .050, .055, .060, .065, .070, .075, .080, .085, .090, .095, .100, .150, .200, .250, .300, .350, .400, .450, .500, .550, .600, .650, .700, .750, .800, .850, .900, .950, .0001, .0002, .0003, .0004, .0005, .0006, .0007, .0008, .0009, .0010, .0015, .0020, .0025, .0030, .0035, .0040, .0045, .0050, .0055, .0060, .0065, .0070, .0075, .0080, .0085, .0090, .0095, .0100, .0150, .0200, .0250, .0300, .0350, .0400, .0450, .0500, .0550, .0600, .0650, .0700, .0750, .0800, .0850, .0900, .0950, .1000, .1500, .2000, .2500, .3000, .3500, .4000, .4500, .5000, .5500, .6000, .6500, .7000, .7500, .8000, .8500, .9000, .9500, .00001, .00002, .00003, .00004, .00005, .00006, .00007, .00008, .00009, .00010, .00015, .00020, .00025, .00030, .00035, .00040, .00045, .00050, .00055, .00060, .00065, .00070, .00075, .00080, .00085, .00090, .00095, .00100, .00150, .00200, .00250, .00300, .00350, .00400, .00450, .00500, .00550, .00600, .00650, .00700, .00750, .00800, .00850, .00900, .00950, .01000, .01500, .02000, .02500, .03000, .03500, .04000, .04500, .05000, .05500, .06000, .06500, .07000, .07500, .08000, .08500, .09000, .09500, .10000, .15000, .20000, .25000, .30000, .35000, .40000, .45000, .50000, .55000, .60000, .65000, .70000, .75000, .80000, .85000, .90000, .95000, .000001, .000002, .000003, .000004, .000005, .000006, .000007, .000008, .000009, .000010, .000015, .000020, .000025, .000030, .000035, .000040, .000045, .000050, .000055, .000060, .000065, .000070, .000075, .000080, .000085, .000090, .000095, .000100, .000150, .000200, .000250, .000300, .000350, .000400, .000450, .000500, .000550, .000600, .000650, .000700, .000750, .000800, .000850, .000900, .000950, .001000, .001500, .002000, .002500, .003000, .003500, .004000, .004500, .005000, .005500, .006000, .006500, .007000, .007500, .008000, .008500, .009000, .009500, .010000, .015000, .020000, .025000, .030000, .035000, .040000, .045000, .050000, .055000, .060000, .065000, .070000, .075000, .080000, .085000, .090000, .095000, .100000, .150000, .200000, .250000, .300000, .350000, .400000, .450000, .500000, .550000, .600000, .650000, .700000, .750000, .800000, .850000, .900000, .950000, .0000001, .0000002, .0000003, .0000004, .0000005, .0000006, .0000007, .0000008, .0000009, .0000010, .0000015, .0000020, .0000025, .0000030, .0000035, .0000040, .0000045, .0000050, .0000055, .0000060, .0000065, .0000070, .0000075, .0000080, .0000085, .0000090, .0000095, .0000100, .0000150, .0000200, .0000250, .0000300, .0000350, .0000400, .0000450, .0000500, .0000550, .0000600, .0000650, .0000700, .0000750, .0000800, .0000850, .0000900, .0000950, .0001000, .0001500, .0002000, .0002500, .0003000, .0003500, .0004000, .0004500, .0005000, .0005500, .0006000, .0006500, .0007000, .0007500, .0008000, .0008500, .0009000, .0009500, .0010000, .0015000, .0020000, .0025000, .0030000, .0035000, .0040000, .0045000, .0050000, .0055000, .0060000, .0065000, .0070000, .0075000, .0080000, .0085000, .0090000, .0095000, .0100000, .0150000, .0200000, .0250000, .0300000, .0350000, .0400000, .0450000, .0500000, .0550000, .0600000, .0650000, .0700000, .0750000, .0800000, .0850000, .0900000, .0950000, .1000000, .1500000, .2000000, .2500000, .3000000, .3500000, .4000000, .4500000, .5000000, .5500000, .6000000, .6500000, .7000000, .7500000, .8000000, .8500000, .9000000, .9500000, .00000001, .00000002, .00000003, .00000004, .00000005, .00000006, .00000007, .00000008, .00000009, .00000010, .00000015, .00000020, .00000025, .00000030, .00000035, .00000040, .00000045, .00000050, .00000055, .00000060, .00000065, .00000070, .00000075, .00000080, .00000085, .00000090, .00000095, .00000100, .00000150, .00000200, .00000250, .00000300, .00000350, .00000400, .00000450, .00000500, .00000550, .00000600, .00000650, .00000700, .00000750, .00000800, .00000850, .00000900, .00000950, .00001000, .00001500, .00002000, .00002500, .00003000, .00003500, .00004000, .00004500, .00005000, .00005500, .00006000, .00006500, .00007000, .00007500, .00008000, .00008500, .00009000, .00009500, .00010000, .00015000, .00020000, .00025000, .00030000, .00035000, .00040000, .00045000, .00050000, .00055000, .00060000, .00065000, .00070000, .00075000, .00080000, .00085000, .00090000, .00095000, .00100000, .00150000, .00200000, .00250000, .00300000, .00350000, .00400000, .00450000, .00500000, .00550000, .00600000, .00650000, .00700000, .00750000, .00800000, .00850000, .00900000, .00950000, .01000000, .01500000, .02000000, .02500000, .03000000, .03500000, .04000000, .04500000, .05000000, .05500000, .06000000, .06500000, .07000000, .07500000, .08000000, .08500000, .09000000, .09500000, .10000000, .15000000, .20000000, .25000000, .30000000, .35000000, .40000000, .45000000, .50000000, .55000000, .60000000, .65000000, .70000000, .75000000, .80000000, .85000000, .90000000, .95000000, .000000001, .000000002, .000000003, .000000004, .000000005, .000000006, .000000007, .000000008, .000000009, .000000010, .000000015, .000000020, .000000025, .000000030, .000000035, .000000040, .000000045, .000000050, .000000055, .000000060, .000000065, .000000070, .000000075, .000000080, .000000085, .000000090, .000000095, .000000100, .000000150, .000000200, .000000250, .000000300, .000000350, .000000400, .000000450, .000000500, .000000550, .000000600, .000000650, .000000700, .000000750, .000000800, .000000850, .000000900, .000000950, .000001000, .000001500, .000002000, .000002500, .000003000, .000003500, .000004000, .000004500, .000005000, .000005500, .000006000, .000006500, .000007000, .000007500, .000008000, .000008500, .000009000, .000009500, .000010000, .000015000, .000020000, .000025000, .000030000, .000035000, .000040000, .000045000, .000050000, .000055000, .000060000, .000065000, .000070000, .000075000, .000080000, .000085000, .000090000, .000095000, .000100000, .000150000, .000200000, .000250000, .000300000, .000350000, .000400000, .000450000, .000500000, .000550000, .000600000, .000650000, .000700000, .000750000, .000800000, .000850000, .000900000, .000950000, .001000000, .001500000, .002000000, .002500000, .003000000, .003500000, .004000000, .004500000, .005000000, .005500000, .006000000, .006500000, .007000000, .007500000, .008000000, .008500000, .009000000, .009500000, .010000000, .015000000, .020000000, .025000000, .030000000, .035000000, .040000000, .045000000, .050000000, .055000000, .060000000, .065000000, .070000000, .075000000, .080000000, .085000000, .090000000, .095000000, .100000000, .150000000, .200000000, .250000000, .300000000, .350000000, .400000000, .450000000, .500000000, .550000000, .600000000, .650000000, .700000000, .750000000, .800000000, .850000000, .900000000, .950000000, .0000000001, .0000000002, .0000000003, .0000000004, .0000000005, .0000000006, .0000000007, .0000000008, .0000000009, .0000000010, .0000000015, .0000000020, .0000000025, .0000000030, .0000000035, .0000000040, .0000000045, .0000000050, .0000000055, .0000000060, .0000000065, .0000000070, .0000000075, .0000000080, .0000000085, .0000000090, .0000000095, .0000000100, .0000000150, .0000000200, .0000000250, .0000000300, .0000000350, .0000000400, .0000000450, .0000000500, .0000000550, .0000000600, .0000000650, .0000000700, .0000000750, .0000000800, .0000000850, .0000000900, .0000000950, .0000001000, .0000001500, .0000002000, .0000002500, .0000003000, .0000003500, .0000004000, .0000004500, .0000005000, .0000005500, .0000006000, .0000006500, .0000007000, .0000007500, .0000008000, .0000008500, .0000009000, .0000009500, .0000010000, .0000015000, .0000020000, .0000025000, .0000030000, .0000035000, .0000040000, .0000045000, .0000050000, .0000055000, .0000060000, .0000065000, .0000070000, .0000075000, .0000080000, .0000085000, .0000090000, .0000095000, .0000100000, .0000150000, .0000200000, .0000250000, .0000300000, .0000350000, .0000400000, .0000450000, .0000500000, .0000550000, .0000600000, .0000650000, .0000700000, .0000750000, .0000800000, .0000850000, .0000900000, .0000950000, .0001000000, .0001500000, .0002000000, .0002500000, .0003000000, .0003500000, .0004000000, .0004500000, .0005000000, .0005500000, .0006000000, .0006500000, .0007000000, .0007500000, .0008000000, .0008500000, .0009000000, .0009500000, .0010000000, .0015000000, .0020000000, .0025000000, .0030000000, .0035000000, .0040000000, .0045000000, .0050000000, .0055000000, .0060000000, .0065000000, .0070000000, .0075000000, .0080000000, .0085000000, .0090000000, .0095000000, .0100000000, .0150000000, .0200000000, .0250000000, .0300000000, .0350000000, .0400000000, .0450000000, .0500000000, .0550000000, .0600000000, .0650000000, .0700000000, .0750000000, .0800000000, .0850000000, .0900000000, .0950000000, .1000000000, .1500000000, .2000000000, .2500000000, .3000000000, .3500000000, .4000000000, .4500000000, .5000000000, .5500000000, .6000000000, .6500000000, .7000000000, .7500000000, .8000000000, .8500000000, .9000000000, .9500000000, .00000000001, .00000000002, .00000000003, .00000000004, .00000000005, .00000000006, .00000000007, .00000000008, .00000000009, .00000000010, .00000000015, .00000000020, .00000000025, .00000000030, .00000000035, .00000000040, .00000000045, .00000000050, .00000000055, .00000000060, .00000000065, .00000000070, .00000000075, .00000000080, .00000000085, .00000000090, .00000000095, .00000000100, .00000000150, .00000000200, .00000000250, .00000000300, .00000000350, .00000000400, .00000000450, .00000000500, .00000000550, .00000000600, .00000000650, .00000000700, .00000000750, .00000000800, .00000000850, .00000000900, .00000000950, .00000001000, .00000001500, .00000002000, .00000002500, .00000003000, .00000003500, .00000004000, .00000004500, .00000005000, .00000005500, .00000006000, .00000006500, .00000007000, .00000007500, .00000008000, .00000008500, .00000009000, .00000009500, .00000010000, .00000015000, .00000020000, .00000025000, .00000030000, .00000035000, .00000040000, .00000045000, .00000050000, .00000055000, .00000060000, .00000065000, .00000070000, .00000075000, .00000080000, .00000085000, .00000090000, .00000095000, .00000100000, .00000150000, .00000200000, .00000250000, .00000300000, .00000350000, .00000400000, .00000450000, .00000500000, .00000550000, .00000600000, .00000650000, .00000700000, .00000750000, .00000800000, .00000850000, .00000900000, .00000950000, .00001000000, .00001500000, .00002000000, .00002500000, .00003000000, .00003500000, .00004000000, .00004500000, .00005000000, .00005500000, .00006000000, .00006500000, .00007000000, .00007500000, .00008000000, .00008500000, .00009000000, .00009500000, .00010000000, .00015000000, .00020000000, .00025000000, .00030000000, .00035000000, .00040000000, .00045000000, .00050000000, .00055000000, .00060000000, .00065000000, .00070000000, .00075000000, .00080000000, .00085000000, .00090000000, .00095000000, .00100000000, .00150000000, .00200000000, .00250000000, .00300000000, .00350000000, .00400000000, .00450000000, .00500000000, .00550000000, .00600000000, .00650000000, .00700000000, .00750000000, .00800000000, .00850000000, .00900000000, .00950000000, .01000000000, .01500000000, .02000000000, .02500000000, .03000000000, .03500000000, .04000000000, .04500000000, .05000000000, .05500000000, .06000000000, .06500000000, .07000000000, .07500000000, .08000000000, .08500000000, .09000000000, .09500000000, .10000000000, .15000000000, .20000000000, .25000000000, .30000000000, .35000000000, .40000000000, .45000000000, .50000000000, .55000000000, .60000000000, .65000000000, .70000000000, .75000000000, .80000000000, .85000000000, .90000000000, .95000000000, .000000000001, .000000000002, .000000000003, .000000000004, .000000000005, .000000000006, .000000000007, .000000000008, .000000000009, .000000000010, .000000000015, .000000000020, .000000000025, .000000000030, .000000000035, .000000000040, .000000000045, .000000000050, .000000000055, .000000000060, .000000000065, .000000000070, .000000000075, .000000000080, .000000000085, .000000000090, .000000000095, .000000000100, .000000000150, .000000000200, .000000000250, .000000000300, .000000000350, .000000000400, .000000000450, .000000000500, .000000000550, .000000000600, .000000000650, .000000000700, .000000000750, .000000000800, .000000000850, .000000000900, .000000000950, .000000001000, .000000001500, .000000002000, .000000002500, .000000003000, .000000003500, .000000004000, .000000004500, .000000005000, .000000005500, .000000006000, .0000000	
---	--

# Hammonds Model 600RO-1P Injector Manual

ITEM	PART NO.	QTY.	DESCRIPTION
1	102810	1	RESERVOIR
2	101070	3 or 5	NIPPLE, 1/4" x 1-1/2" (OPT)
2A	101069	2 or 0	NIPPLE, 1/4" x 1" (OPT)
3	101230	1	ON/OFF VALVE, 1/4"
4	101034	1	TUBE ADAPTER, 3/8" (OPT)
	101170	1	TUBE ADAPTER, 1/2" (OPT)
4A	882339	1	JIC ADAPTER, 3/8" (OPT)
	882447	1	JIC ADAPTER, 1/2" (OPT)
5	272151	1	UNION, 1/4" FNPT
6	271125	1	ST EL 1/4" 90
7	101095	2	TUBE ADAPT, 1/2" x 1/4" ELBOW
8	101379	1	1/2" TEFLON TUBE
9	101685	2	1/2" INSERT
10	101337	1	O-RING
11	882562	1	STRAP, VINYL COATED (OPT)
12	881292	1	SOC HD CAP SCREW (OPT)
13	103028	1	FLAT WASHER (OPT)
14	881881	1	LOCK NUT (OPT)
15	102735	1	VENT VALVE, 1/4"
16	101057	1	TUBE ADAPTER, 1/4"
17	101059-01	1	VENT TUBE, 1/4"
18	152070	1	CALIBRATED GAUGE GUARD
19		1	SIGHT FLOW INDICATOR (OPT)
20	271827	1	Y-STRAINER, 1/4", 60 MESH (OPT)

\* SIZE AND MATERIAL AS NEEDED FOR INDIVIDUAL APPLICATIONS

NOTE: PIPE FITTINGS VARY DEPENDING UPON THE VARIOUS PUMP ARRANGEMENT

*TOLERANCES*					THIS PRINT IS CONFIDENTIAL AND IS THE PROPERTY OF HAMMONDS TECHNICAL SERVICES			HAMMONDS TECHNICAL SERVICES, INC.				
ALL DIMENSIONS ARE IN INCHES UNLESS OTHERWISE SPECIFIED.					*TOL. DECIMALS: .XX= +/- .005 .XX= +/- .015 X= +/- .030 FRAC. = +/- 1/16 *CONCENTRICITY: .005 T.I.R. *REMOVE BURRS AND BREAK EDGES .005 MIN.			SCALE	APPROVED PART NUMBER	DATE	DRAWN BY	
ADDED OPTION	08/18/16	SS	X	DRAWING				LEVELS	VIEW	NTS	SCG206SS	SS
ADDED PART NO.	03/10/15	SS	X	2489				8-10	I	08/20/12	SCG206SS	08/18/16
INITIAL RELEASE	08/20/12	SS	X	FROM SER#				DATE	TO SER#	DATE	REVISED	
NO.	REVISION	DATE	BY	APPVD	X	X	X	DRAWING TITLE				
								GENERAL LAYOUT		DRAWING NUMBER		
										6728		

# Hammonds Model 600RO-1P Injector Manual

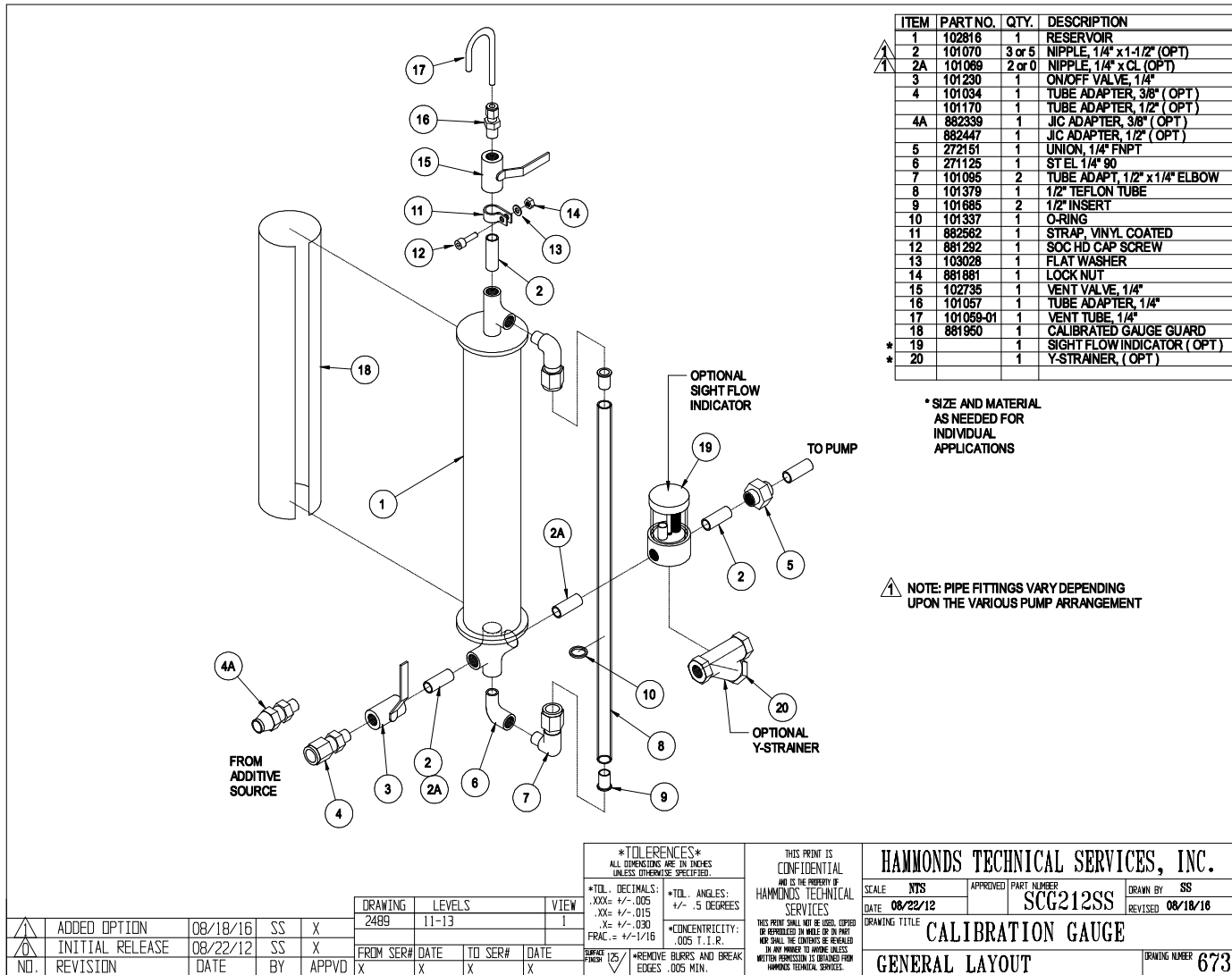

DRAWING				LEVELS				VIEW			
2489				11-13				I			
NO.	REVISION	DATE	BY	APPVD	FROM SER#	DATE	TO SER#	DATE			
				X							

*TOLERANCES* ALL DIMENSIONS ARE IN INCHES UNLESS OTHERWISE SPECIFIED:		THIS PRINT IS CONFIDENTIAL AND IS THE PROPERTY OF HAMMONDS TECHNICAL SERVICES	
*TOL. DECIMALS: .XX= +/- .005 .XX= +/- .015 .X= +/- .030 FRAC. = +/- 1/16	*TOL. ANGLES: +/- .5 DEGREES	THIS PRINT SHALL NOT BE USED, COPIED OR REPRODUCED IN WHOLE OR IN PART NOR SHALL THE CONTENTS BE REVEALED IN ANY MANNER TO ANYONE UNLESS WRITTEN PERMISSION IS OBTAINED FROM HAMMONDS TECHNICAL SERVICES.	
SURFACE FINISH 125 REMOVE BURRS AND BREAK EDGES .005 MIN.		*CONCENTRICITY: .005 T.I.R.	

<b>HAMMONDS TECHNICAL SERVICES, INC.</b>			
SCALE: NTS	APPROVED PART NUMBER: SCG212SS	DRAWN BY: SS	
DATE: 08/22/12		REVISED: 08/18/16	
DRAWING TITLE: <b>CALIBRATION GAUGE</b>			
GENERAL LAYOUT			DRAWING NUMBER: <b>6730</b>

# Hammonds Model 600RO-1P Injector Manual

## HAMMONDS SUCTION CALIBRATION GAUGE

### CALIBRATION INSTRUCTIONS

- 1) IN ORDER TO CALIBRATE, THE PUMP MUST BE PRIMED AND PURGED OF ALL AIR. THE 3-WAY VALVE MUST BE SET TO INJECT.
- 2) WITH SUPPLY VALVE OPEN, SLOWLY OPEN VENT VALVE. THIS WILL FILL CALIBRATION GAUGE. FILL TO ZERO MARK. DO NOT OVERFILL. ONCE FULL, CLOSE VENT VALVE.
- 3) MAKE NOTE OF ADDITIVE LEVEL IN CALIBRATION GAUGE AND MAIN PRODUCT METER READING. BEGIN CALIBRATION BY FIRST CLOSING THE SUPPLY VALVE AND THEN OPENING THE VENT VALVE. START THE PRODUCT FLOW (SET FOR A SHORT TRIAL RUN).
- 4) AT THE END OF THE RUN, RECORD THE AMOUNT OF ADDITIVE THAT WAS DRAWN FROM THE CALIBRATION GAUGE. RECORD THE AMOUNT OF FUEL PUMPED. CLOSE THE VENT VALVE. OPEN THE SUPPLY VALVE.
- 5) DIVIDE THE AMOUNT OF ADDITIVE USED BY THE VOLUME OF FUEL THAT WAS PUMPED GIVING YOU PPM.
- 6) INCREASE OR DECREASE PERCENTAGE OF STROKE ON PUMP TO OBTAIN DESIRED INJECTION RATIO.

EXAMPLE: (METRIC)  
ADDITIVE INJECTED = 500 ML  
FUEL DELIVERED = 1785 LITERS

$$\frac{500}{1785} = .280$$

$$\frac{.280}{1000} = .000280 \text{ (280 MILLIONTHS)}$$

$$\text{OR } 280 \text{ PPM (PARTS PER MILLION)}$$

EXAMPLE: (US)  
ADDITIVE INJECTED = 11.5 oz  
FUEL DELIVERED = 350 GALLONS

$$\frac{11.5}{350} = .0328$$

$$\frac{.0328}{128 \text{ oz/gal}} = .000256 \text{ (256 MILLIONTHS)}$$

$$\text{OR } 256 \text{ PPM (PARTS PER MILLION)}$$

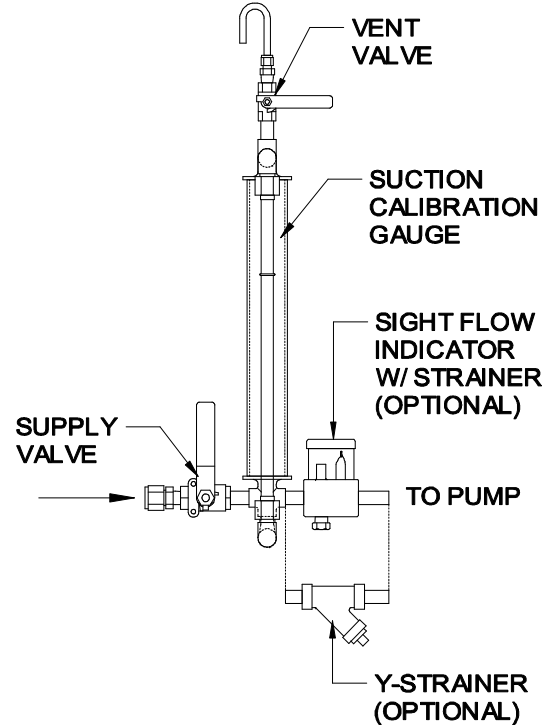

<table border="1" style="width: 100%; border-collapse: collapse;"> <tr> <td style="width: 15%;">DRAWING</td> <td style="width: 15%;">LEVELS</td> <td style="width: 15%;">VIEW</td> </tr> <tr> <td>1891</td> <td>5,6</td> <td>I</td> </tr> </table>					DRAWING	LEVELS	VIEW	1891	5,6	I	<p><b>*TOLERANCES*</b> ALL DIMENSIONS ARE IN INCHES UNLESS OTHERWISE SPECIFIED.</p> <p>*TOL. DECIMALS: .XX± +/- .005 .XX± +/- .015 .X± +/- .030 FRAC. ± 1/16</p>		<p>THIS PRINT IS CONFIDENTIAL AND IS THE PROPERTY OF HAMMONDS TECHNICAL SERVICES</p> <p>*TOL. ANGLES: +/- .5 DEGREES</p> <p>*CONCENTRICITY: .005 T. I. R.</p>		<p><b>HAMMONDS TECHNICAL SERVICES, INC.</b></p>					
					DRAWING	LEVELS	VIEW													
1891	5,6	I																		
<table border="1" style="width: 100%; border-collapse: collapse;"> <tr> <td>SCALE</td> <td>NTS</td> <td>APPROVED</td> <td>PART NUMBER</td> <td>DRAWN BY</td> <td>SS</td> </tr> <tr> <td>DATE</td> <td>12/20/07</td> <td></td> <td></td> <td>REVISED</td> <td>08/17/12</td> </tr> </table>		SCALE	NTS	APPROVED	PART NUMBER	DRAWN BY	SS	DATE	12/20/07			REVISED	08/17/12	<p>THIS PRINT SHALL NOT BE USED, COPIED OR REPRODUCED IN WHOLE OR IN PART WITHOUT PERMISSION IS OBTAINED FROM HAMMONDS TECHNICAL SERVICES.</p>		<p>DRAWING TITLE</p> <p><b>SUCTION CALIBRATION GAUGE</b></p>				
SCALE	NTS	APPROVED	PART NUMBER	DRAWN BY	SS															
DATE	12/20/07			REVISED	08/17/12															
<table border="1" style="width: 100%; border-collapse: collapse;"> <tr> <td>NO.</td> <td>REVISION</td> <td>DATE</td> <td>BY</td> <td>APPV'D</td> </tr> <tr> <td> </td> <td> </td> <td> </td> <td> </td> <td> </td> </tr> </table>					NO.	REVISION	DATE	BY	APPV'D						<p>REMOVE BURRS AND BREAK EDGES .005 MIN.</p>		<p>MODELS SCG206SS &amp; SCG212SS</p>		<p>DRAWING NUMBER</p> <p><b>1891S</b></p>	
NO.	REVISION	DATE	BY	APPV'D																

# Hammonds Model 600RO-1P Injector Manual

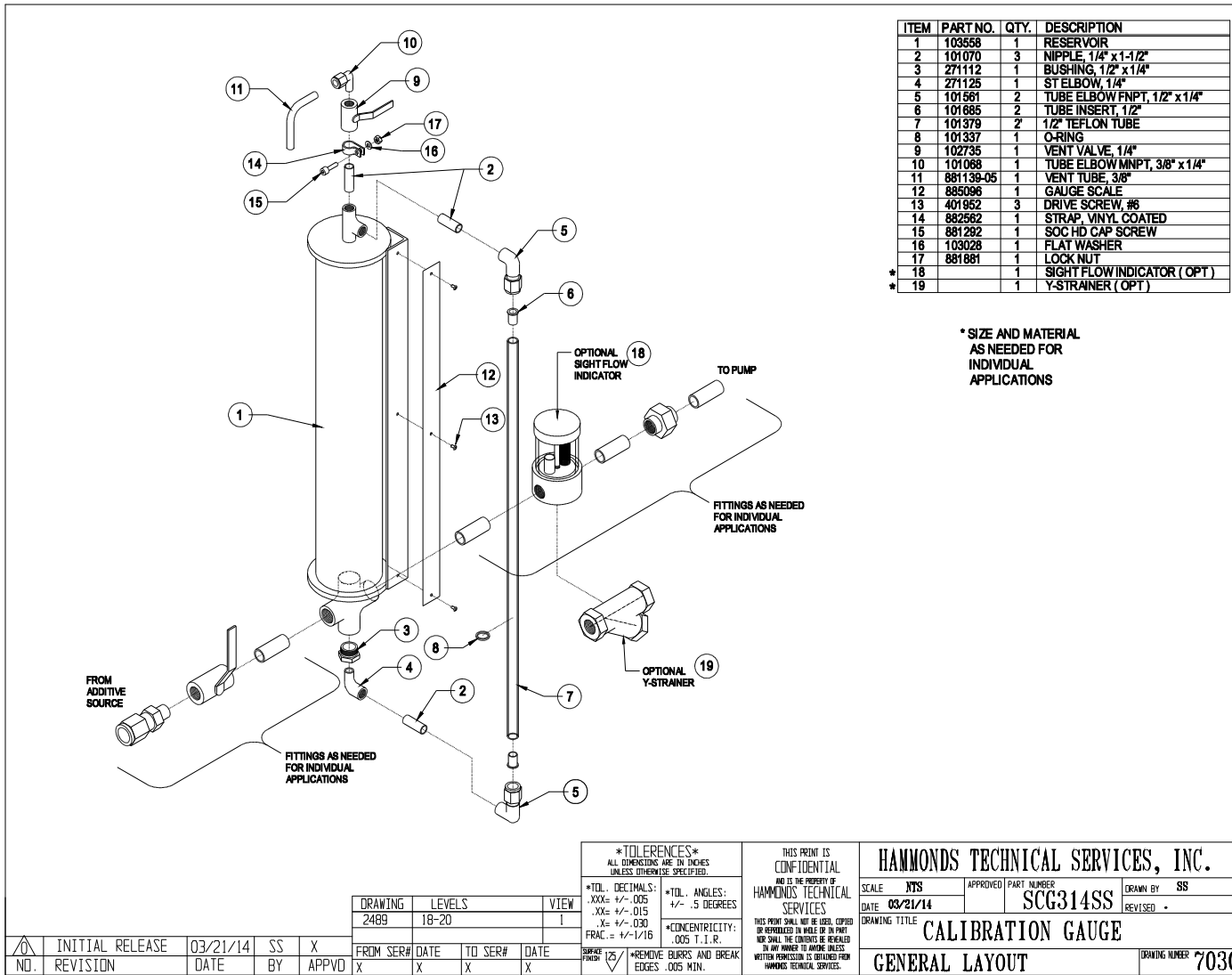

*TOLERANCES* ALL DIMENSIONS ARE IN INCHES UNLESS OTHERWISE SPECIFIED:				THIS PRINT IS <b>CONFIDENTIAL</b> AND IS THE PROPERTY OF HAMMONDS TECHNICAL SERVICES		<b>HAMMONDS TECHNICAL SERVICES, INC.</b>					
				*TOL. DECIMALS: .XX= +/- .005 .XX= +/- .015 .X= +/- .030 FRAC. = +/- 1/16		*TOL. ANGLES: +/- .5 DEGREES *CONCENTRICITY: .005 T.I.R.		THIS PRINT SHALL NOT BE USED, COPIED OR REPRODUCED IN WHOLE OR IN PART NOR SHALL THE CONTENTS BE RELEASED IN ANY MANNER TO ANYONE UNLESS WRITTEN PERMISSION IS OBTAINED FROM HAMMONDS TECHNICAL SERVICES.			
DRAWING NO. 2489		LEVELS 18-20		VIEW 1		SCALE NTS		APPROVED PART NUMBER SCG314SS		DRAWN BY SS	
DATE 03/21/14		BY SS		APPVD X		DATE 03/21/14		REVISED -		DRAWING TITLE	
INITIAL RELEASE		DATE 03/21/14		BY SS		APPVD X		FROM SER#		DATE	
NO.		REVISION		DATE		BY		APPVD		FROM SER#	
X		X		X		X		X		DATE	
X		X		X		X		X		X	
X		X		X		X		X		X	
X		X		X		X		X		X	
X		X		X		X		X		X	
X		X		X		X		X		X	
X		X		X		X		X		X	
X		X		X		X		X		X	
X		X		X		X		X		X	
X		X		X		X		X		X	
X		X		X		X		X		X	
X		X		X		X		X		X	
X		X		X		X		X		X	
X		X		X		X		X		X	
X		X		X		X		X		X	
X		X		X		X		X		X	
X		X		X		X		X		X	
X		X		X		X		X		X	
X		X		X		X		X		X	
X		X		X		X		X		X	
X		X		X		X		X		X	
X		X		X		X		X		X	
X		X		X		X		X		X	
X		X		X		X		X		X	
X		X		X		X		X		X	
X		X		X		X		X		X	
X		X		X		X		X		X	
X		X		X		X		X		X	
X		X		X		X		X		X	
X		X		X		X		X		X	
X		X		X		X		X		X	
X		X		X		X		X		X	
X		X		X		X		X		X	
X		X		X		X		X		X	
X		X		X		X		X		X	
X		X		X		X		X		X	
X		X		X		X		X		X	
X		X		X		X		X		X	
X		X		X		X		X		X	
X		X		X		X		X		X	
X		X		X		X		X		X	
X		X		X		X		X		X	
X		X		X		X		X		X	
X		X		X		X		X		X	
X		X		X		X		X		X	
X		X		X		X		X		X	
X		X		X		X		X		X	
X		X		X		X		X		X	
X		X		X		X		X		X	
X		X		X		X		X		X	
X		X		X		X		X		X	
X		X		X		X		X		X	
X		X		X		X		X		X	
X		X		X		X		X		X	
X		X		X		X		X		X	
X		X		X		X		X		X	
X		X		X		X		X		X	
X		X		X		X		X		X	
X		X		X		X		X		X	
X		X		X		X		X		X	
X		X		X		X		X		X	
X		X		X		X		X		X	
X		X		X		X		X		X	
X		X		X		X		X		X	
X		X		X		X		X		X	
X		X		X		X		X		X	
X		X		X		X		X		X	
X		X		X		X		X		X	
X		X		X		X		X		X	
X		X		X		X		X		X	
X		X		X		X		X		X	
X		X		X		X		X		X	
X		X		X		X		X		X	
X											

# Hammonds Model 600RO-1P Injector Manual

## HAMMONDS SUCTION CALIBRATION GAUGE

### CALIBRATION INSTRUCTIONS

- 1) IN ORDER TO CALIBRATE, THE PUMP MUST BE PRIMED AND PURGED OF ALL AIR. THE 3-WAY VALVE MUST BE SET TO INJECT.
- 2) WITH SUPPLY VALVE OPEN, SLOWLY OPEN VENT VALVE. THIS WILL FILL CALIBRATION GAUGE. FILL TO ZERO MARK. DO NOT OVERFILL. ONCE FULL, CLOSE VENT VALVE.
- 3) MAKE NOTE OF ADDITIVE LEVEL IN CALIBRATION GAUGE AND MAIN PRODUCT METER READING. BEGIN CALIBRATION BY FIRST CLOSING THE SUPPLY VALVE AND THEN OPENING THE VENT VALVE. START THE PRODUCT FLOW (SET FOR A SHORT TRIAL RUN).
- 4) AT THE END OF THE RUN, RECORD THE AMOUNT OF ADDITIVE THAT WAS DRAWN FROM THE CALIBRATION GAUGE. RECORD THE AMOUNT OF FUEL PUMPED. CLOSE THE VENT VALVE. OPEN THE SUPPLY VALVE.
- 5) DIVIDE THE AMOUNT OF ADDITIVE USED BY THE VOLUME OF FUEL THAT WAS PUMPED GIVING YOU PPM.
- 6) INCREASE OR DECREASE PUMP INJECTION RATIO AS NEEDED.

EXAMPLE: (METRIC)  
 ADDITIVE INJECTED = 500 ML  
 FUEL DELIVERED = 1785 LITERS

$$\frac{500}{1785} = .280$$

$$.280 = .000280 \text{ (280 MILLIONTHS)}$$

$$\frac{.280}{1000} \text{ OR } 280 \text{ PPM (PARTS PER MILLION)}$$

EXAMPLE: (US)  
 ADDITIVE INJECTED = 11.5 oz  
 FUEL DELIVERED = 350 GALLONS

$$\frac{11.5}{350} = .0328$$

$$\frac{.0328}{128 \text{ oz/gal}} = .000256 \text{ (256 MILLIONTHS)}$$

$$\text{OR } 256 \text{ PPM (PARTS PER MILLION)}$$

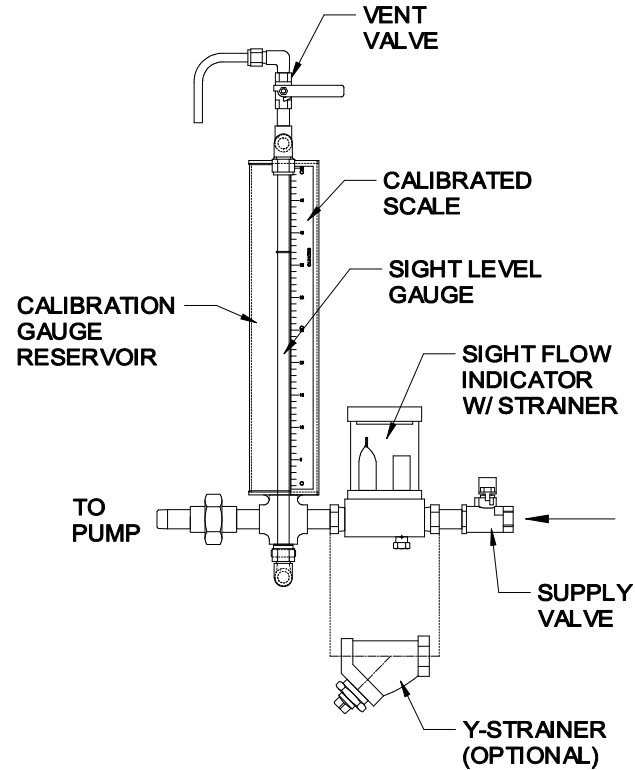

<table border="1" style="width: 100%; border-collapse: collapse;"> <tr> <th>DRAWING</th> <th>LEVELS</th> <th>VIEW</th> </tr> <tr> <td>1891</td> <td>10, 11</td> <td>1</td> </tr> </table>					DRAWING	LEVELS	VIEW	1891	10, 11	1	<p>*TOLERANCES*                  ALL DIMENSIONS ARE IN INCHES UNLESS OTHERWISE SPECIFIED.</p> <p>*TOL. DECIMALS:                  .XX± ±.005                  .XX± ±.015                  .X± ±.030                  FRAC. ± ±1/16</p> <p>*TOL. ANGLES:                  ±.5 DEGREES</p> <p>*CONCENTRICITY:                  .005 T.I.R.</p> <p>*REMOVE BURRS AND BREAK EDGES .005 MIN.</p>		<p>THIS PRINT IS CONFIDENTIAL AND IS THE PROPERTY OF HAMMONDS TECHNICAL SERVICES</p> <p>THIS PRINT SHALL NOT BE USED, COPIED OR REPRODUCED IN WHOLE OR IN PART NOR SHALL THE CONTENTS BE REVEALED IN ANY MANNER TO WHOMEVER WITHOUT PERMISSION IS OBTAINED FROM HAMMONDS TECHNICAL SERVICES.</p>		<p><b>HAMMONDS TECHNICAL SERVICES, INC.</b></p>												
					DRAWING	LEVELS	VIEW																				
1891	10, 11	1																									
<p>SCALE: NTS</p> <p>DATE: 02/27/13</p> <p>DRAWING TITLE: SCG314SS CALIBRATION GAUGE</p> <p>OPERATION</p>		<p>APPROVED PART NUMBER: .</p> <p>REVISION: .</p>		<p>DRAWN BY: SSS</p> <p>REVISED: .</p>		<p>DRAWING NUMBER: 6815</p>																					
<table border="1" style="width: 100%; border-collapse: collapse;"> <tr> <th>NO.</th> <th>REVISION</th> <th>DATE</th> <th>BY</th> <th>APPVD</th> </tr> <tr> <td>1</td> <td>INITIAL RELEASE</td> <td>02/27/13</td> <td>SS</td> <td>X</td> </tr> </table>					NO.	REVISION	DATE	BY	APPVD	1	INITIAL RELEASE	02/27/13	SS	X	<table border="1" style="width: 100%; border-collapse: collapse;"> <tr> <th>FROM SER#</th> <th>DATE</th> <th>TO SER#</th> <th>DATE</th> </tr> <tr> <td>X</td> <td>X</td> <td>X</td> <td>X</td> </tr> </table>					FROM SER#	DATE	TO SER#	DATE	X	X	X	X
NO.	REVISION	DATE	BY	APPVD																							
1	INITIAL RELEASE	02/27/13	SS	X																							
FROM SER#	DATE	TO SER#	DATE																								
X	X	X	X																								

# Hammonds Model 600RO-1P Injector Manual

		DRAWING		LEVELS		VIEW			
		2918		10, 30		1			
		FROM SER#		DATE		TO SER#		DATE	
		X		X		X		X	

*TOLERANCES* ALL DIMENSIONS ARE IN INCHES UNLESS OTHERWISE SPECIFIED. *TOL. DECIMALS: .XX± +/- .005 .XX± +/- .015 .X± +/- .030 FRAC. ± +/- 1/16 *TOL. ANGLES: +/- .5 DEGREES *CONCENTRICITY: .005 T. I. R. *REMOVE BURRS AND BREAK EDGES .005 MIN.		THIS PRINT IS CONFIDENTIAL AND IS THE PROPERTY OF HAMMONDS TECHNICAL SERVICES THIS PRINT SHALL NOT BE USED, COPIED OR REPRODUCED IN WHOLE OR IN PART NOR SHALL THE CONTENTS BE REVEALED IN ANY MANNER TO WHOMEVER WRITTEN PERMISSION IS OBTAINED FROM HAMMONDS TECHNICAL SERVICES.	
---	--	--	--

HAMMONDS TECHNICAL SERVICES, INC.			
SCALE	XYS	APPROVED PART NUMBER	DRAWN BY SSS
DATE	07/15/96		REVISED 02/09/11
DRAWING TITLE PROPER INJECTOR POSITIONING			
			DRAWING NUMBER 2918-1