

**OPERATING INSTRUCTIONS
AND
MAINTENANCE MANUAL
FOR**

HAMMONDS MODEL AC600-1P7

**FLUID POWERED
ADDITIVE INJECTOR CART**

Manufactured by:



HAMMONDS TECHNICAL SERVICES, INC.

6807 West Little York Rd.
Houston, Texas 77040

Phone: 281-999-2900

Fax: 281-847-1857

www.hammondscos.com

January 2017

Hammonds Model AC600-1P7 Injection Cart Manual

TABLE OF CONTENTS

Special Notice to Users	3
Installation and Preparation for Startup	3-4
Preparation for Calibration and Startup	4
Calibration and Startup	5-7
Additive Chart	8
Trouble Shooting the System	8-9
Preventive Maintenance	9-10
Preventive Maintenance Schedule	10
Desiccant Dryer Instructions	11

Attachments:

- AC600 Cart System Layout
- Hydraulic Schematic
- Model 600 Driver
- Gear Reducer (if equipped)
- Injector Pump
- Diaphragm Replacement (if equipped)
- Calibration Gauge Parts
- Calibration Gauge Instructions
- Drum Connection / Operation (if equipped)
- Installing a New Drum of Additive (if equipped)
- Tank Illustration
- Grounding Reel Instructions

Hammonds Model AC600-1P7 Injection Cart Manual

SPECIAL NOTICE TO USERS PLEASE READ CAREFULLY BEFORE OPERATING EQUIPMENT

This additive injector system is designed to give consistent dependable performance when operated and maintained according to manufacturer's recommendations. However, being a mechanical device, it is subject to failure from improper installation, wear, human error and operating environments beyond the control of the system. Because of this fact, it is the responsibility of the operator to make certain that:

- A. The system is installed properly.
- B. The system is being operated properly.
- C. The system is actually running during product transfer.
- D. The system is checked after the transfer operation to make certain the proper amount of additive was injected during the operation.

The performing of these checks by the operator eliminates the possibility of product not having the proper additive ratio as required. Therefore, since the manufacturer cannot be present during each transfer operation, the responsibility for checking the performance of the system is that of the operator. Should there be any questions whatsoever, the operator should consult the distributor from whom the unit was purchased.

Do Not Take Chances.....Do Not Guess.....Be Absolutely Certain That The System Is Installed And Working As It Should.

The user/operator carries the final responsibility to make certain the system is operating properly.

INSTALLATION AND PREPARATION FOR STARTUP

In most cases, the Hammonds fluid powered injector is shipped complete and ready to operate. The system should include appropriate fittings to suit your specific application. Flow direction is marked on additive pumps and check valves.

CAUTION

Do Not Attempt To Use This Device Without Understanding And Following Proper Safety Precautions Regarding System Grounding, Fire Safety, And Special Handling For Potentially Dangerous Additives.

Consult your Engineering Department for their specific instructions. Make certain all

personnel involved with this system are thoroughly familiar with safe operating practices.

If your system has been purchased "bare," consult your equipment distributor for help in selecting hoses, fittings and other related accessories. Selection of materials compatibility, location of unit within the system, effect of the unit on the system and injection point of the additive are also factors that should be discussed by factory authorized personnel.

If no factory-authorized distributor is available, consult the factory directly for assistance.

Hammonds Model AC600-1P7 Injection Cart Manual

POINT OF INJECTION OF ADDITIVE

Some additives may adversely affect other components in the product handling systems, for example seals in meters, valve seals, aluminum and filter elements to name a few. The Hammonds injector systems do an excellent job of mixing the additive in the product, and does not inject in large slugs. Because of this superior mixing and very small concentration of additive in any one point, many customers feel that this is not a problem. **SOME DO**, and therefore, should use their own judgment as to the effect of these additives.

Hammonds Technical Services, Inc. Can Only Advise You Of The Possible Hazards.

It is up to the owner to decide his preference as to location of the additive injection point. It can be placed at any point in the system. The model 600 comes with the injection point directly ahead of the fluid motor for good blending. It can be located elsewhere very easily. If the injection point is moved from the body of the injector, the 1/4" tapped hole must be plugged, the inlet check valve moved to the new location, and the injection tubing rerouted to the new location. An injection check valve must always be used regardless of location.

PREPARATION FOR CALIBRATION AND STARTUP

Before Attempting To Start The System Or Make Calibrations, Please Read The Following Information Carefully.

During startup and calibration, you will be bleeding the system of air and checking for possible leaks throughout the system. Provisions should be made for collection or clean-up of spilled fluid. Attempts should be made to minimize losses during these procedures. If the additive being handled is flammable, fire safety precautions should be taken.

A WORD ABOUT ADDITIVES

Most additives being used in fuels today have at least some degree of toxicity. Many are very dangerous. Extreme caution should be taken in handling additives. Remember, the additive is placed under pressure when being injected into the line. Be careful; wear protective clothing including eye protection. Be sure you have facilities to wash off any additive that may

come in contact with your skin. Read all additive manufacturers safety precautions and Material Safety Data Sheets, following them to the letter.

HERE IS WHAT IS NEEDED:

- Appropriate safety protection equipment.
 - Eye protection in the form of safety goggles.
 - A marked graduated glass bottle that is marked in either cc's or ounces. (At least 16 oz.)
 - A stop watch.
 - A means of determining the flow rate of the main system.
 - A small pocket calculator is helpful.
 - A clipboard is helpful with pad of paper.
- AT LEAST ONE AND PREFERABLY TWO HELPERS**

REMEMBER: Any plumbing system varies with temperature and fluid being pumped. The system also changes as parts of the pump wear.

Hammonds Model AC600-1P7 Injection Cart Manual

CALIBRATION AND STARTUP

IF YOUR INJECTOR SYSTEM IS EQUIPED WITH CALIBRATION GAUGES, FOLLOW THE INSTRUCTIONS FOR THEIR USE IN THE BACK OF THIS MANUAL.

PROPER ADDITIVE INJECTION RATIOS

Although volumetric calibration at atmospheric pressure will bring you within an acceptable range of additive injection, the only true evaluation for proper ratio is the ASTM D-5006 evaluation for fuel system ice inhibitor (FSII). Do not depend on volumetric calibration to ensure on-spec performance because line pressures can vary and additive injector parts wear over time. Contact Hammonds Fuel Additives, Inc. for supply of quality fuel system ice inhibitor and fuel testing procedures.

Please Follow These Steps In Their Given Order. Read Them Over Carefully Before Starting, Then Follow Them To The Letter. If There is Any Part Of The Procedure That Is Not Clear, Consult Your Local Distributor Or The Factory Directly.

1. Make certain the additive tank/drum is at least $\frac{1}{4}$ full of the proper additive.
2. Open the suction valve between the tank and the pump. This valve should be located at any point between the additive tank and the injector.
3. All systems are calibrated at the factory to customer specified requirements. So if adjustments are required, they should only

be minor. If this is the case, go directly to step 6.

4. If you are starting from scratch in the calibration and adjustment, loosen the stroke adjustment locking screws located on the bottom of the pump body directly under the stroke adjustment knob. This will allow the stroke adjustment to be moved.

5. Adjust the stroke adjustment knobs located on the pump face to approximately 50%. **CAUTION:** Do not turn these adjustments with excessive force. If they are difficult to adjust, simply rotate the main rotor shaft, by producing flow in main product line. Lock the stroke adjustment locking screws down firmly.

6. Set the calibration valve (3-way valve) in the "calibrate or bleed position." This is done by making certain that the handle on the valve is positioned so that additive will exit through the short open tube.

7. Make certain all product connections going to and from the system are in their proper, locked position to ensure safe, leak proof flow of product through the fluid motor. Double check the flow direction arrows located on the fluid motor housing, and check valves before and after the pump to ensure that the system is installed properly.

8. At this point, consider the information you will have to gather during the next few steps of the calibration process.

A. What will the flow rate through the unit be?

Hammonds Model AC600-1P7 Injection Cart Manual

B. What is the length of time that the calibration will cover?

C. What is the amount of additive in ounces or cc's that you will need to collect based on the duration of the calibration.

You Should Have the Answer To All Of These Questions Before Your First Trial Run.

9. Before starting the main product flow through the system, make certain everyone understands that you will run the system for, let's say, one (1) minute. Even shorter runs are fine, especially if you are running at high flow rates.

10. Place the measured graduate under the calibration tube. Put on your eye protection.

11. At the command of the time keeper, or that person watching the flow meter, start the main product pumps.

12. Give the system a few seconds to gather momentum and flow through the fluid motor. Notice if the additive injector system is turning. The bearing on the shaft under the stroke adjustment knob cover should be spinning.

13. If the pump is being started up for the first time, it will take a few seconds to prime itself and begin discharging fluid from the calibration tube. Is your eye protection on? If not, **PUT IT ON NOW!**

14. As soon as the pump begins discharging a clear, air free stream of fluid from the calibration tube, you are ready to begin your calibration. At this point, the system is primed.

***Hammonds recommends using the Pressure Simulating Calibration Device, an optional accessory item, to duplicate system pressure during calibration.**

15. You will now prepare to make your first actual calibration run. Empty your collected additive back into the tank, putting the bottle back under the calibration tube. Notice the setting on the main product meter, set your stop watch at zero.

16. When ready, start the system again. Stop it at the decided time interval or meter reading. Calculate the amount of product that traveled through the system. Measure the amount of additive gathered, and record the amount of elapsed time.

17. It will be at this time that you will have to calculate how much additive you should have collected for the amount of fuel that the system pumped. This, of course, depends upon the ratio that is required. The following example is the easiest way of explaining the procedure without getting too complicated. It is not the only way...use it if you like.

Example condition: Amount of product pumped: 500 gallons

Ratio of additive desired: 250 PPM (Parts per million)

It is assumed that the operator will know how much product is being pumped through the system in a given length of time. If, for example, you have a meter that registers the flow in gallons, you simply record the gallons at the beginning of the timed run, and then again at the end of the run. If you run for one (1) minute, you simply subtract the beginning number on the meter from the number registered after

Hammonds Model AC600-1P7 Injection Cart Manual

the run. This will give you the gallons per minute (GPM). Having to make this calculation is the only reason for timing the run. You can accomplish the same result by just watching the meter and stopping the system when you have totaled the desired amount of gallons through the system. In any case, you must know the amount of product passing through the system before calibration can begin.

First, change the gallons pumped into ounces by multiplying total gallons (in our example 500) by 128 (128 oz. to a gallon). The answer is 64,000 ounces.

Second, divide by 1,000,000. The answer is .06. Since you are dealing in 1/1,000,000 (one part per million) of the total for your ratio, you must find out what 1/1,000,000 of the 500 gallons is, .06 ounces is 1/1,000,000th (one part per million) of 500 gallons.

Third, multiply the .06 x 250 (for 250 PPM ratio). The answer is 15 ounces.

So, you should collect 15 ounces of additive for every 500 gallons of fuel pumped.

These are all large, round numbers. You may, for example, only be running at 100 GPM, not 500. Use the same procedure; just change the numbers to fit your application.

No two systems will ever perform exactly the same. For this reason, the procedures given for calibration are general in nature. Obviously, it is impossible to provide a graph or table that would be absolutely accurate in every case. With that in mind, all tables and graphs should be used as

general guidelines. Remember, the calculated, timed and measured output that you gather is absolute. Trust your figures and your calculations.

NORMAL OPERATION

Following initial start up and calibration, the system requires very little attention other than making certain that additive tank levels are maintained. Operators will quickly become accustomed to the performance of the system by observing the Calibration Gauge glass or Sight Flow Indicator. On-spec injection will cause a certain response in the indicators, and with some practice, operators will be able to observe the system at a glance. *This does not mean that system calibration should not be periodically checked!* However, during a busy workload, these visual checks will provide assurance to the operator that the system is functioning.

Assuming the system remains set up and operating at least intermittently, calibration is required perhaps every 1 – 3 months. Good record keeping of additive inventory and use levels compared to fuel handled can give a good indication that additive is on specification. Test such as the refractometer for FSII content should be the final test to verify additive injection ratios.

Hammonds Model AC600-1P7 Injection Cart Manual

SAMPLE ADDITIVE CHART

GALLONS	135 PPM	270 PPM	1000 PPM
100	1.7 OZ.	3.4 OZ.	12.8 OZ.
200	3.4 OZ.	6.9 OZ.	25.6 OZ.
400	6.9 OZ.	13.8 OZ.	51.2 OZ.
500	8.6 OZ.	17.2 OZ.	64.0 OZ.
700	12.0 OZ.	24.0 OZ.	89.6 OZ.
1000	17.2 OZ.	34.5 OZ.	128.0 OZ.

TROUBLESHOOTING THE SYSTEM

The following conditions are given as a means of troubleshooting the system. Each condition lists a number of possible causes. In most cases, trouble can be solved by the use of this section. Please read it carefully before attempting repairs or making changes in the system.

FLUID MOTOR IS NOT TURNING

- A. Insufficient flow to turn the motor. A minimum flow of about 20 GPM is needed to start the system.
- B. A rag or some other object is jammed in the line preventing the fluid motor from turning.
- C. A diverter valve is blocked downstream of the system, blocking the fuel flow through the system.
- D. A valve is closed upstream of the fluid motor starving the product flow.
- E. If the unit has been recently serviced internally, or it is new, the rotor might be installed backwards. Consult the factory before disassembly.

INJECTOR IS TURNING AND PUMP IS RUNNING, BUT WITH NO OUTPUT

- A. Pump is air-locked. In some cases where there is a very long line running from the injector head and the point of injection into the system, there is sufficient air volume to cause the pump to act as a compressor. It is not able to open the valves throughout the system and therefore, cannot pull a suction of fluid to the pump. Loosen the connection at the injection point check valve and allow it to remain open until the pump begins pumping. This is rare, but can happen in some cases of unusual installations.
- B. One or more of the suction or discharge check valves are not working. While the pump is running, tap on the side of the valves, one at a time. This will generally jar them loose. The poppet/seal is very small, and will sometimes become stuck. After the valve is loosened and has a supply of fluid, usually it will not stick again.
- C. The pump is not getting additive. Check the valve between the pump and the tank. Check all connections in the line between the pump and the tank.
- D. The vent on the tank is not open causing the pump to pull a vacuum. Open the vent. Check to see if the cap has been removed from the dryer cartridge, if so equipped.

Hammonds Model AC600-1P7 Injection Cart Manual

- E. The pump stroke is set at zero. Check to see if the locking screws have been left loose, allowing the adjustment knobs to rotate to zero percent (0%) of stroke.
- F. The additive tank/drum is empty...don't laugh, it happens.

THE INJECTOR IS OPERATING BUT WITH REDUCED OUTPUT

- A. Leaking suction line or trash in discharge check valve.
- B. Air leak in suction side of system.
- C. Defective tubing or piping on suction side.
- D. Leaks in threaded connections - suction side.

E. If so equipped, a relief valve on injector may be bleeding part of the output back to suction. Relief valve may not be working, or retaining nut may have vibrated loose causing valve to fail entirely, bleeding output back to suction.

F. Injector diaphragm may be pulled out in back causing injector to pump in forward portion of stroke only. This will not create a visible leak but will reduce output by 50%. It usually happens after many hours of operation.

G. Fluid motor vanes are badly worn. This would only be probable after a very high number of hours of operation.

PREVENTIVE MAINTENANCE

1. Make certain to use only clean, fresh additive that has been stored in a sealed container. Most additives are moisture sensitive. Some will form heavy crystals if allowed to accumulate moisture. These crystals will stop the pump in very short order, if not cause calibration to be changed due to clogging of the valves and other parts.
2. Check the additive filter screen at least every six months. More often if there is an indication of possible contamination.
3. Check the system for leaks at every use. This is an extremely important safety procedure, since some additives are flammable, caustic and corrosive.
4. Check for leaks from the seal that is located at the exit point of the injector output shaft in the side plate housing. This should be done at each operation. Leakage at this point usually indicates that

the mechanical seal inside the rotor housing is leaking. A leak here will be fuel, and is not only dangerous from a fire standpoint, but will quickly ruin the bearings on the rotor shaft, since all lubricant will be washed away.

5. Check the fittings for leakage around the Calibration Gauge or Sight Flow Indicator, if one is used on the pump. Check this fitting each time the filter is changed or cleaned. Make certain there are no leaks in the suction line. A very small leak will either change the operation of the pump or prevent it from operating all together.

6. Visually check around the pump head and make certain there is no leaking of additive around the fluid ends. If there is, check the tightness of the head bolts. (40 inch pounds each)

7. Check the grease around the eccentric drive bearing in the pump every 6 months. Use a good quality white lithium spray lubricant.

Hammonds Model AC600-1P7 Injection Cart Manual

8. It is recommended that the injector diaphragm or plunger o-ring be changed at least every 12 months. Every 6 months under extreme operating conditions. Doing so will prevent unexpected failures and unscheduled downtime.

Hammonds injectors are very dependable. If installed properly and sized appropriately to the application, they require very little maintenance. Remember; keep the additive clean, and the suction strainer clean. If you have problems with the pump working, it is usually in the suction side of

the system (between the injection pump and the additive tank). Suction lines and fittings are notorious for leaking just enough to prevent the system from working. Always check to ensure optimum suction conditions should problems occur.

Remember, a leak in the suction allows air from the outside to be introduced into the system. It does not always mean a visible leak of additive. If the pump loses its prime or output is erratic, chances are good that there are problems in the suction side. Otherwise, if it is working...leave it alone!!!!

PREVENTATIVE MAINTENANCE SCHEDULE

NOTE: It is important to read the previous pages on preventative maintenance. These intervals are general, and may vary according to individual applications and severity of service.

SERVICE FUNCTION	0-4 HRS DAILY	5-8 HRS DAILY	8+HRS DAILY
Check gear oil level (if equipped with worm gear reducer)	Monthly	Monthly	Monthly
Check additive filter screen	Monthly	Monthly	Monthly
Check system for additive/fuel leaks	Daily	Daily	Daily
Inspect diaphragms/plunger seals	12 Months	6 Months	3 Months
Replace diaphragms/plunger seals	12 Months	As needed	As needed
Check eccentric bearing grease	6 Months	3 Months	Monthly
Check stroke adjustment parts for looseness	Monthly	Monthly	Monthly
Replace stroke adjustment parts	24 Months	As needed	As needed
Disassemble and inspect turbine housing and internal parts	24 Months	12 Months	8 Months
Grease bearings	12 Months	6 Months	3 Months

Hammonds Model AC600-1P7 Injection Cart Manual

DESICCANT DRYER

Your Hammonds Additive Injector Cart includes 1 or more additive tanks or a drum. These tanks may come equipped with a desiccant dryer cartridge. These dryers come in several different sizes.

Most systems are equipped with the standard 3/4" cartridge. This unit is attached to the tank via a short length of black rubber hose. The cartridge has a housing constructed of a clear poly material and is filled with a blue colored desiccant crystal. All these units are shipped from the factory with a small yellow cap on the each end of the cartridge.

Some systems may come equipped with a large canister measuring approximately 2" diameter and 10" in length. These units perform the same function, just on a larger scale. Due to their greater capacity, they last longer between service. These units are sealed from the factory by a small, plastic plug which is located either on the bottom or one side of the canister.

The purpose of all desiccant dryers is simply to remove moisture from the air as the system breathes. All tanks or portable sources of additive supply must be vented to atmosphere in order for the injector to operate. If moisture in this venting air is not removed, some additives are either ruined or seriously damaged. Fuel system icing inhibitor (FSII), for example, is designed to seek out water in a fluid. So, when enough moisture is absorbed into the container, the FSII is diluted and at some point will be ruined. Biobor® JF, an anti-fungal material, will form crystals in the presence of moisture and not only perform unsatisfactorily as an additive, but will stop up pumps and lines as well.

The following instructions apply to all desiccant cartridges:

- A. Remove the caps or plugs when the system is placed into service.
- B. Observe the color of the desiccant. The original color is blue. As moisture is absorbed, the color will change to pink. When the cartridge is completely pink, it should either have its contents removed, dried and replaced, or the entire unit replaced.

C. NOTE: The contents can be removed from plastic container, placed on a pan and baked at 400°F in a conventional oven until the moisture has been removed. When the color blue returns, the cooled material may be reinstalled into plastic containers and is again ready for service.

- D. Color change and cartridge life is totally dependent on humidity. The more moist the air, the shorter the life. Keeping it dry is especially important if additive is not consumed rapidly. Check daily and service as needed.

Hammonds Model AC600-1P7 Injection Cart Manual

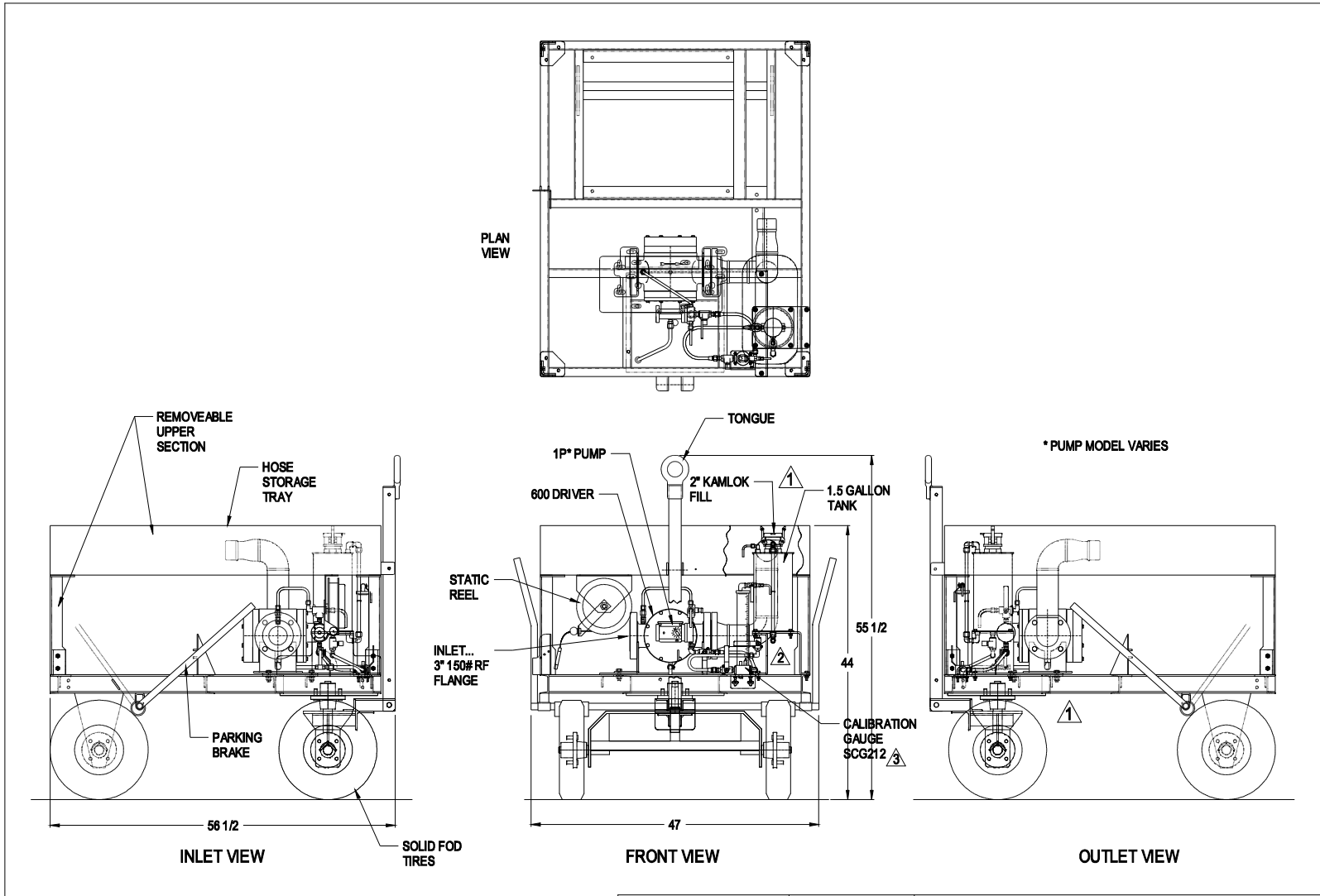

<table border="1" style="width: 100%; border-collapse: collapse;"> <tr> <td style="width: 15px;">3</td> <td>WAS SCG206</td> <td>12/20/16</td> <td>SS</td> <td>X</td> </tr> <tr> <td>2</td> <td>REV. TANK SUPPORT</td> <td>04/15/14</td> <td>SS</td> <td>X</td> </tr> <tr> <td>1</td> <td>UPDATED CART</td> <td>03/06/14</td> <td>SS</td> <td>X</td> </tr> <tr> <td>0</td> <td>INITIAL RELEASE</td> <td>05/29/13</td> <td>SS</td> <td>X</td> </tr> <tr> <td>NO.</td> <td>REVISION</td> <td>DATE</td> <td>BY</td> <td>APPVD</td> </tr> </table>		3	WAS SCG206	12/20/16	SS	X	2	REV. TANK SUPPORT	04/15/14	SS	X	1	UPDATED CART	03/06/14	SS	X	0	INITIAL RELEASE	05/29/13	SS	X	NO.	REVISION	DATE	BY	APPVD	<table border="1" style="width: 100%; border-collapse: collapse;"> <tr> <td style="width: 15px;">DRAWING</td> <td style="width: 15px;">LEVELS</td> <td style="width: 15px;">VIEW</td> </tr> <tr> <td>ACCART</td> <td>70-75, 125</td> <td>I</td> </tr> </table>		DRAWING	LEVELS	VIEW	ACCART	70-75, 125	I	<p style="font-size: small;">*TOLERANCES* ALL DIMENSIONS ARE IN INCHES UNLESS OTHERWISE SPECIFIED.</p> <p style="font-size: x-small;">*TOL. DECIMALS: .XXX= +/- .005 .XX= +/- .015 .X= +/- .030 FRAC.= +/- 1/16</p> <p style="font-size: x-small;">*TOL. ANGLES: +/- .5 DEGREES</p> <p style="font-size: x-small;">*CONCENTRICITY: .005 T.I.R.</p> <p style="font-size: x-small;">*REMOVE BURRS AND BREAK EDGES .005 MIN.</p>		<p style="font-size: small;">THIS PRINT IS CONFIDENTIAL AND IS THE PROPERTY OF HAMMONDS TECHNICAL SERVICES</p> <p style="font-size: x-small;">THIS PRINT SHALL NOT BE LOANED, COPIED OR REPRODUCED IN WHOLE OR IN PART NOR SHALL THE CONTENTS BE RELEASED IN ANY MANNER TO ANYONE UNLESS WRITTEN PERMISSION IS OBTAINED FROM HAMMONDS TECHNICAL SERVICES.</p>		<p style="text-align: center; font-weight: bold;">HAMMONDS TECHNICAL SERVICES, INC.</p> <table border="1" style="width: 100%; border-collapse: collapse;"> <tr> <td style="width: 15%;">SCALE</td> <td style="width: 15%;">NTS</td> <td style="width: 15%;">APPROVED</td> <td style="width: 15%;">PART NUMBER</td> <td style="width: 15%;">DRAWN BY</td> <td style="width: 15%;">SS</td> </tr> <tr> <td>DATE</td> <td>05/29/13</td> <td></td> <td></td> <td>REVISED</td> <td>12/20/16</td> </tr> </table>		SCALE	NTS	APPROVED	PART NUMBER	DRAWN BY	SS	DATE	05/29/13			REVISED	12/20/16
		3	WAS SCG206	12/20/16	SS	X																																														
2	REV. TANK SUPPORT	04/15/14	SS	X																																																
1	UPDATED CART	03/06/14	SS	X																																																
0	INITIAL RELEASE	05/29/13	SS	X																																																
NO.	REVISION	DATE	BY	APPVD																																																
DRAWING	LEVELS	VIEW																																																		
ACCART	70-75, 125	I																																																		
SCALE	NTS	APPROVED	PART NUMBER	DRAWN BY	SS																																															
DATE	05/29/13			REVISED	12/20/16																																															
						<p style="text-align: center; font-weight: bold;">DRAWING TITLE HAMMONDS AC600-1P* CART</p> <p style="text-align: center; font-weight: bold;">1.5 GAL & "LOW PROFILE"</p>		<p style="text-align: right; font-weight: bold;">DRAWING NUMBER 6881</p>																																												

Hammonds Model AC600-1P7 Injection Cart Manual

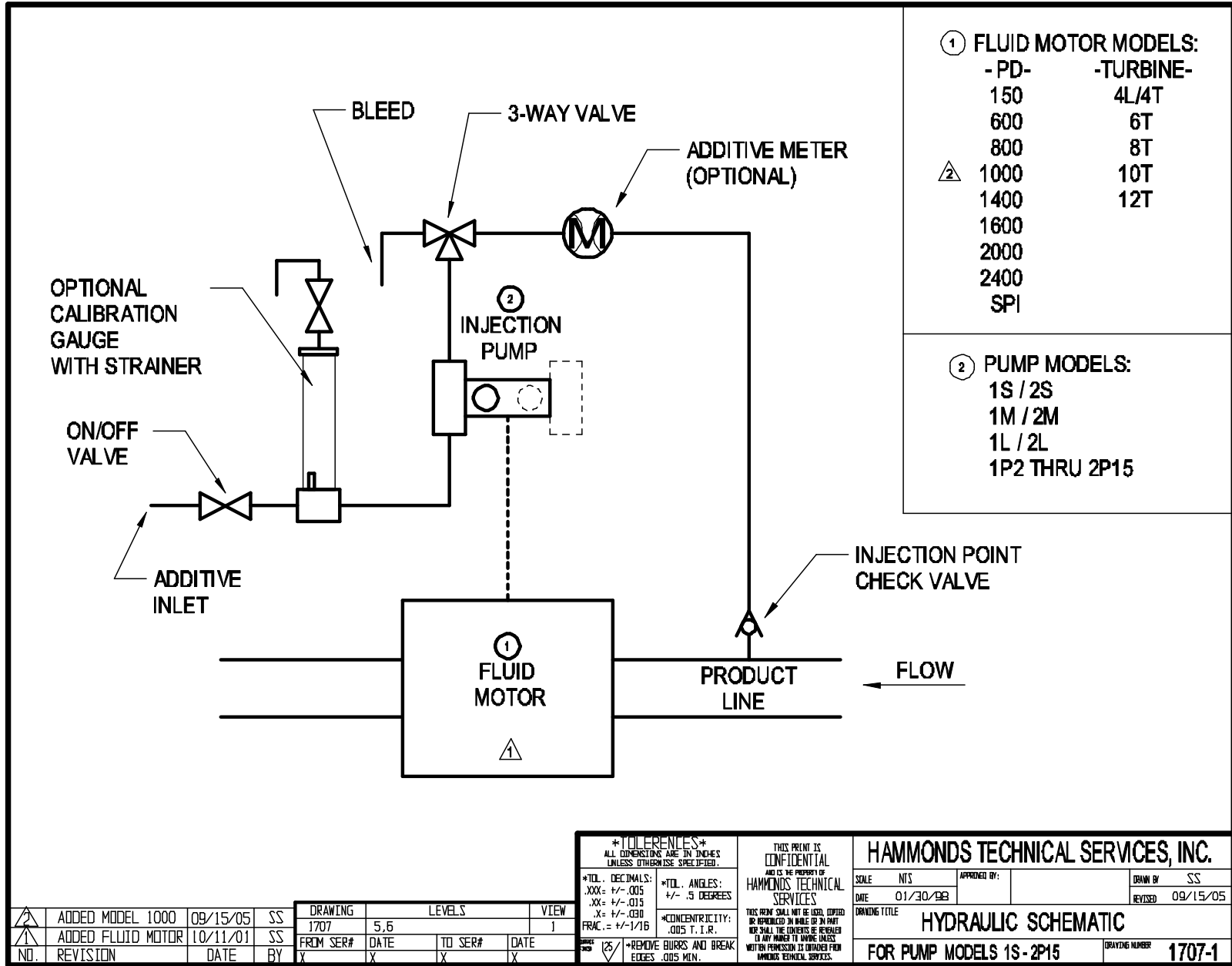

△	ADDED MODEL 1000	09/15/05	SS
△	ADDED FLUID MOTOR	10/11/01	SS
NO.	REVISION	DATE	BY

DRAWING	LEVELS	VIEW
1707	5,6	1
FROM SER#	DATE	TO SER#
X	X	X

TOLERANCES
ALL DIMENSIONS ARE IN INCHES UNLESS OTHERWISE SPECIFIED.

*TOL. DECIMALS:
.XXX = +/- .005
.XX = +/- .015
.X = +/- .030
FRAC. = +/- 1/16

*TOL. ANGLES:
+/- .5 DEGREES

*CONCENTRICITY:
.005 T. I. R.

*REMOVE BURRS AND BREAK EDGES .005 MIN.

THIS PRINT IS CONFIDENTIAL AND IS THE PROPERTY OF HAMMONDS TECHNICAL SERVICES

THIS PRINT SHALL NOT BE USED, COPIED OR REPRODUCED IN WHOLE OR IN PART OR SHALL THE CONTENTS BE REVEALED TO ANY NUMBER TO WHOME UNLESS WITH THE PERMISSION IS GRANTED FROM HAMMONDS TECHNICAL SERVICES.

HAMMONDS TECHNICAL SERVICES, INC.			
SCALE	NTS	APPROVED BY:	DRAWN BY SS
DATE	01/30/98		REVISED 09/15/05
DRAWING TITLE			
HYDRAULIC SCHEMATIC			
FOR PUMP MODELS 1S-2P15			DRAWING NUMBER 1707-1

Hammonds Model AC600-1P7 Injection Cart Manual

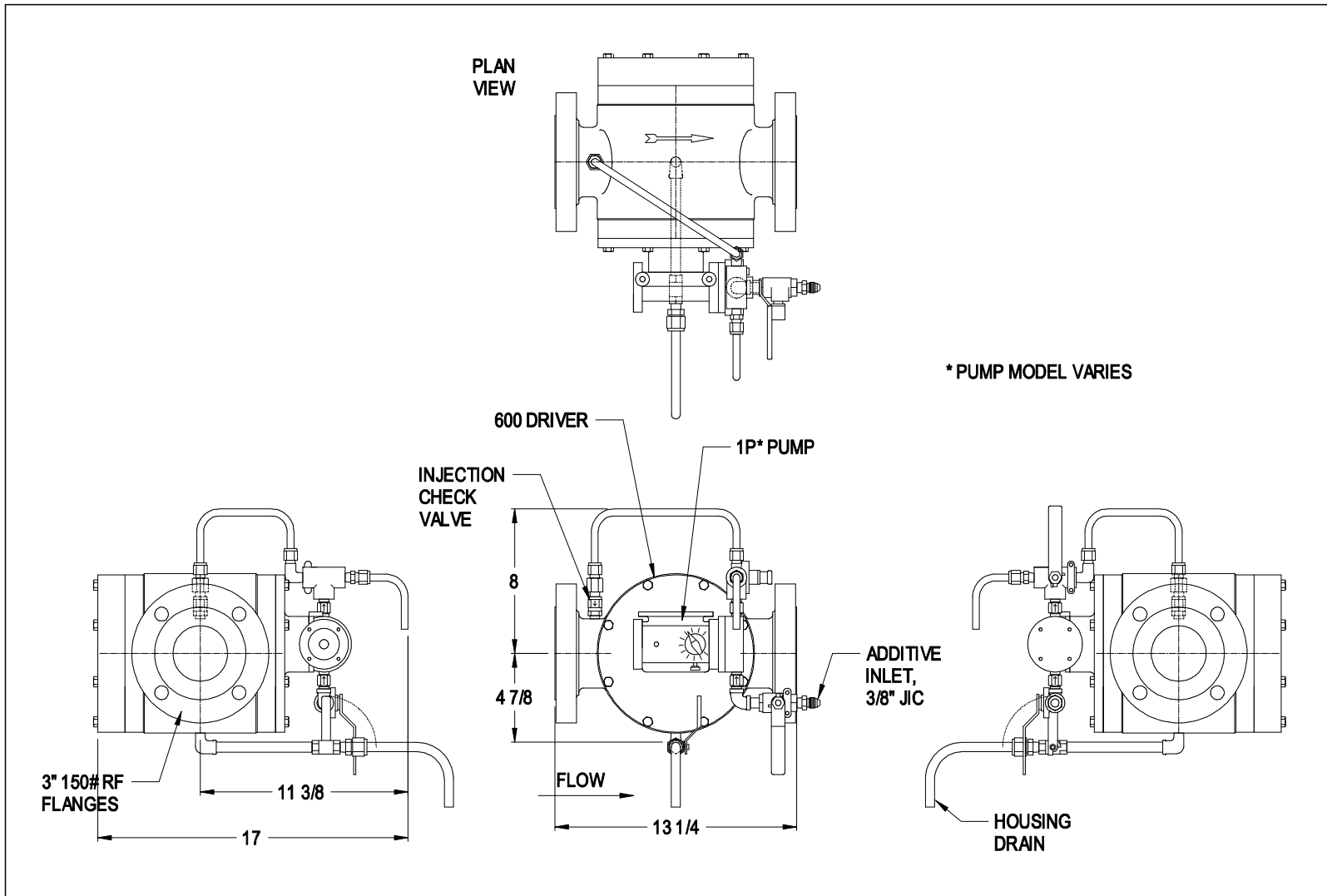

TOLERANCES ALL DIMENSIONS ARE IN INCHES UNLESS OTHERWISE SPECIFIED.				THIS PRINT IS CONFIDENTIAL AND IS THE PROPERTY OF HAMMONDS TECHNICAL SERVICES				HAMMONDS TECHNICAL SERVICES, INC.			
*TOL. DECIMALS: .XXX = +/- .005 .XX = +/- .015 .X = +/- .030 FRAC. = +/- 1/16		*TOL. ANGLES: +/- .5 DEGREES		*CONCENTRICITY: .005 T.I.R.		SCALE: NTS		APPROVED PART NUMBER		DRAWN BY: SS	
SURFACE FINISH: 125		*REMOVE BLURS AND BREAK EDGES .005 MIN.		THIS PRINT SHALL NOT BE USED, COPIED OR REPRODUCED IN WHOLE OR IN PART NOR SHALL THE CONTENTS BE REVEALED IN ANY MANNER TO ANYONE UNLESS WRITTEN PERMISSION IS OBTAINED FROM HAMMONDS TECHNICAL SERVICES.		DATE: 03/06/14		REVISED:		DRAWING NUMBER: 7017	
DRAWING ACCART LEVELS 142, 143 VIEW I				FROM SER# X DATE X TO SER# X DATE X				DRAWING TITLE: HAMMONDS MODEL 600-1P* FOR ACCART			
INITIAL RELEASE NO. REVISION		03/06/14 DATE		SS BY		X APPVD					

Hammonds Model AC600-1P7 Injection Cart Manual

ITEM	PART NO.	QTY.	DESCRIPTION
1	101045	1	SNAP RING
2	881157	1	PUMP DRIVE BEARING
3	881629	1	SPACER
4	881120	2	BEARING
5	881121	2	SNAP RING
6	881119	3	SNAP RING
7	882011	1	PUMP SIDE PLATE
8	212001	1	SHAFT
9	212002	2	KEY, 3/16" SQ. x 1"
10	141006	1	MECH. SEAL, VITON, STD
	141048	1	MECH. SEAL, BUNA (OPT)
	141009	1	MECH. SEAL, HP (OPT)
11	882012	2	WEAR RING
12	212097	6	VANE, TEFLON
13	212006	1	ROTOR
14	881910	2	O RING, VITON
	881154	2	O RING, BUNA-N (OPT)
15	212008	1	HOUSING, 3" VC.
	212250	1	HOUSING, 3" 150#
16	151005	1	PIPE PLUG, 1/4"
17	212272	1	BEARING, SHIELDED
18	212473	1	BACK PLATE, HD
19	881124	16	LOCKWASHER, 5/16"
20	881125	8	BOLT, 5/16" x 1"
21	881289	8	BOLT, 5/16" x 2 1/4"

2	ADDED BUNA-N OPT	12/10/14	SS	X	DRAWING	LEVELS	VIEW
3	ADDED HP SEAL OPT	01/15/14	SS	X	600DRVR	140, 151, 153-156, 158,	1
0	INITIAL RELEASE	02/18/08	SS	X	FROM SER#	DATE	TO SER#
NO.	REVISION	DATE	BY	APPVD	X	X	X

TOLERANCES
ALL DIMENSIONS ARE IN INCHES UNLESS OTHERWISE SPECIFIED.

*TOL. DECIMALS:
.XXX= +/- .005
.XX= +/- .015
.X= +/- .030
FRAC.= +/- 1/16

*TOL. ANGLES:
+/- .5 DEGREES

*CONCENTRICITY:
.005 T.I.R.

*REMOVE BURRS AND BREAK EDGES .005 MIN.

THIS PRINT IS CONFIDENTIAL AND IS THE PROPERTY OF HAMMONDS TECHNICAL SERVICES

HAMMONDS TECHNICAL SERVICES, INC.

SCALE: **NTS** APPROVED PART NUMBER: DRAWN BY: **SS**

DATE: **02/18/08** . REVISED: **12/10/14**

DRAWING TITLE: **MODEL 600 DRIVER**

EXPLODED VIEW

DRAWING NUMBER: **5833**

Hammonds Model AC600-1P7 Injection Cart Manual

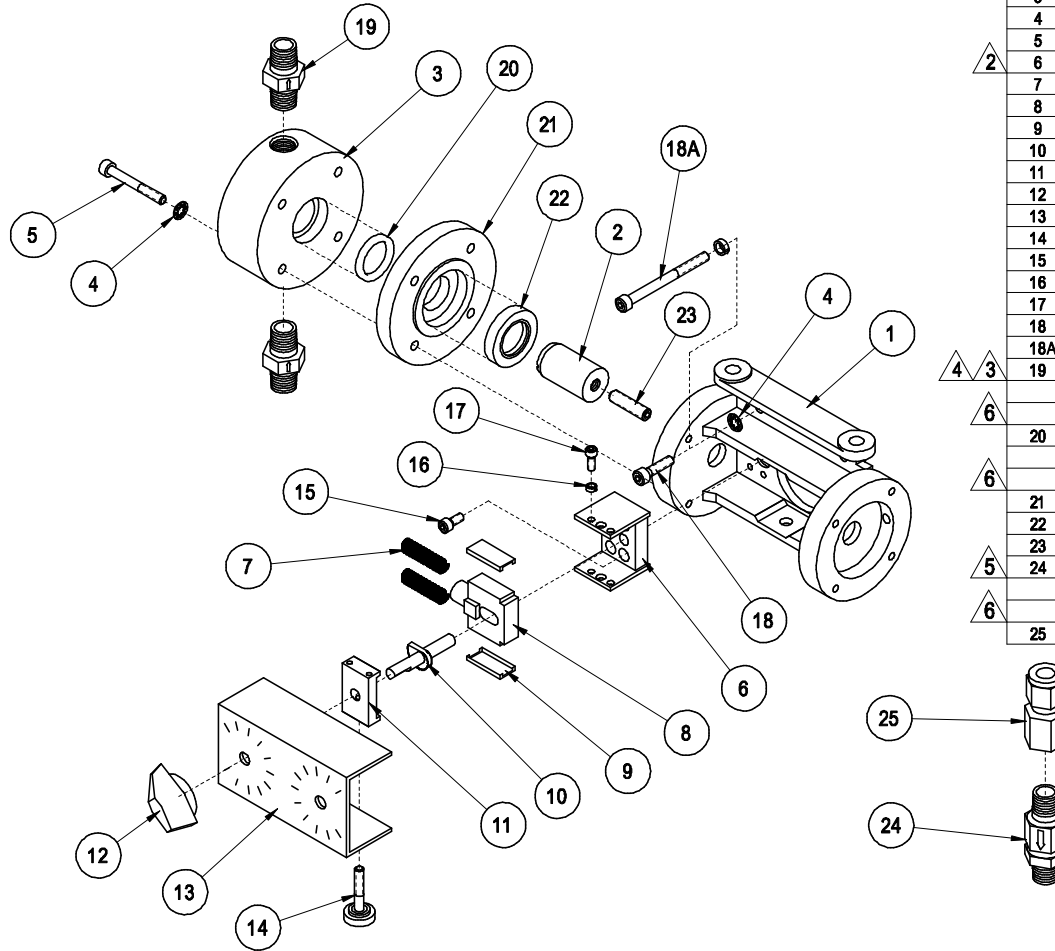

ITEM	PART NO.	QTY.	DESCRIPTION
1	101014	1	POWER FRAME
2	102192	1	PLUNGER, P7
3	102193	1	FLUID END, P7
4	882949	8	LOCK WASHER, #10 INT. TOOTH
5	881317	4	SCREW, 10-32 x 2"
6	101842	1	CROSSHEAD GUIDE
7	101007	2	RETURN SPRING
8	101006	1	CROSSHEAD
9	101152	2	SLIDE BEARING
10	101005	1	STROKE ADJUSTMENT CAM
11	101003	1	CAM GUIDE
12	101001	1	STROKE ADJUSTMENT KNOB
13	101002	1	POWER FRAME COVER
14	101004	1	LOCK SCREW
15	101009	4	SCREW, 8-32 x 3/8"
16	881086	4	LOCKWASHER, #6
17	101010	4	SCREW, 6-32 x 3/8"
18	881089	4	SCREW, 10-32 x 3/4"
18A	881680	4	SCREW, 10-32 x 2 1/4" (OPTION)
19	102463	2	CHECK VALVE, AFLAS
	102464	2	CHECK VALVE, VITON (OPTION)
	102642	2	CHECK VALVE, KALREZ (OPTION)
20	101490	1	O-RING, AFLAS
	101226	1	O-RING, VITON (OPTION)
	101754	1	O-RING, KALREZ (OPTION)
21	102194	1	SEAL HOUSING
22	881765	1	SEAL, LIP
23	881045	1	SETSCREW, 1/4-20 x 1"
24	882911	1	CHECK VALVE, 5 PSI, AFLAS, STD.
	101576	1	CHECK VALVE, 5 PSI, VITON, (OPT)
	102643	1	CHECK VALVE, 5 PSI, KALREZ, (OPT)
25	101088	1	3/8 x 1/4 FNPT TUBE ADAPT.

6	ADDED PART NOS.	01/21/14	SS
5	WAS #101671	03/15/04	SS
4	WAS #101933	03/15/04	SS
3	WAS #102263	09/03/02	SS
2	WAS #101008	08/99	SS
1	ADDED INJ CHK VLV	01/06/98	SS
NO.	REVISION	DATE	BY

DRAWING	LEVELS	VIEW
INJECTOR	10, 12, 14, 16, 18, 20, 24, 28, 30	I
	39-41, 89-93, 95-97, 99, 110, 111	
FROM SER#	DATE	TO SER#
X	X	X

TOLERANCES	
ALL DIMENSIONS ARE IN INCHES UNLESS OTHERWISE SPECIFIED.	
*TOL. DECIMALS:	*TOL. ANGLES:
.XXX = +/- .005	+/- .5 DEGREES
.XX = +/- .015	
.X = +/- .030	
FRAC. = +/- 1/16	
*CONCENTRICITY: .005 T. I. R.	
*REMOVE BURRS AND BREAK EDGES .005 MIN.	

THIS PRINT IS CONFIDENTIAL AND IS THE PROPERTY OF HAMMONDS TECHNICAL SERVICES

THIS PRINT SHALL NOT BE USED, COPIED OR REPRODUCED IN WHOLE OR IN PART WITHOUT THE WRITTEN PERMISSION OF HAMMONDS TECHNICAL SERVICES.

HAMMONDS TECHNICAL SERVICES, INC.			
SCALE	NTS	APPROVED PART NUMBER	DRAWN BY SS
DATE	05/11/93		REVISED 01/21/14
DRAWING TITLE			DRAWING NUMBER
HAMMONDS 1P7 PUMP ASSEMBLY			1911

Hammonds Model AC600-1P7 Injection Cart Manual

**INSTALL CAP HAND-TIGHT...
DO NOT OVER-TIGHTEN!**

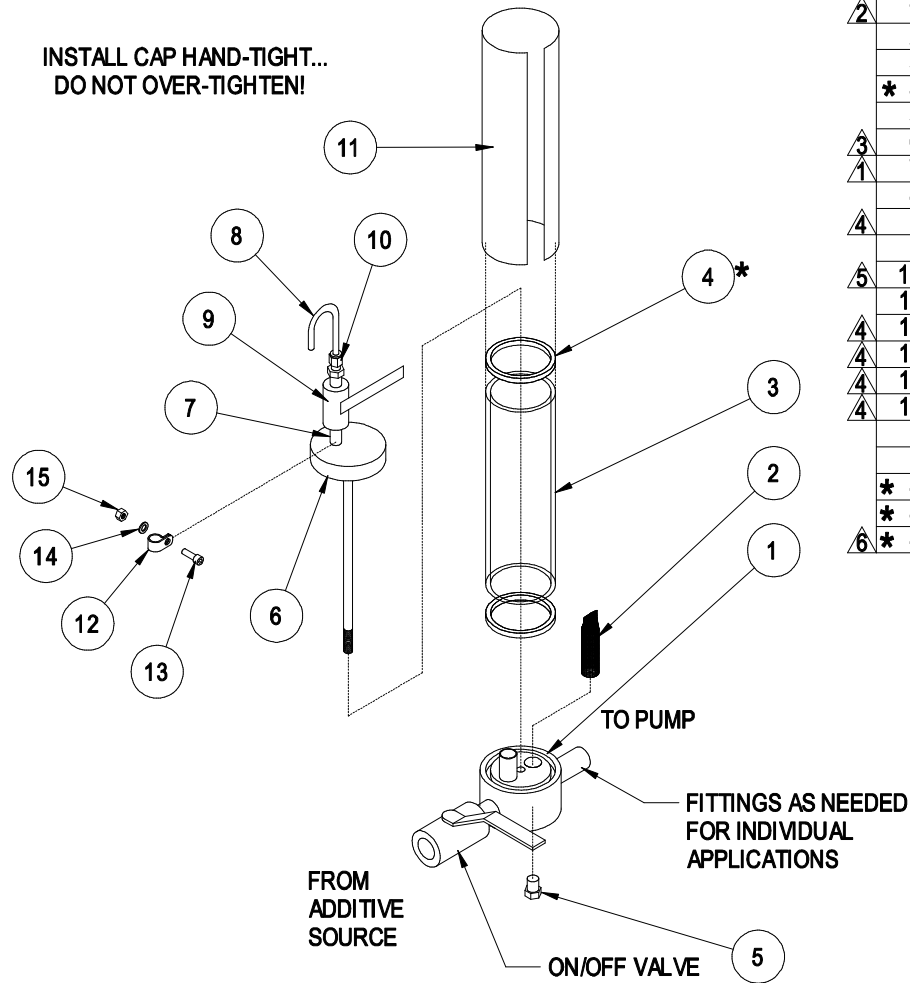

	ITEM	PART NO.	QTY.	DESCRIPTION
2	1	152075	1	BODY, STD.SIGHT FLOW
	2	152002	1	FILTER ELEMENT
	3	151015	1	GAUGE GLASS
	* 4	151002	2	GASKET, BUNA
	5	151005	1	PLUG
3	6	152079	1	CAP ASSEMBLY
1	7	101070	1	NIPPLE, 1/4" x 1 1/2"
	8	101059-01	1	VENT TUBE, 1/4"
4	9	102735	1	ON/OFF VALVE, STD. 1/4"
		101230	1	ON/OFF VALVE, MIL. 1/4", OPT.
5	10	101057	1	TUBE ADAPTER, 1/4"
	11	881950	1	GUARD, GAUGE GLASS
4	12	882562	1	STRAP, VINYL COATED
4	13	881292	1	1/4-20 x 3/4" SOC. HD. CAP SS
4	14	103028	1	1/4" FLAT WASHER SS
4	15	881881	1	1/4-20 LOCK NUT SS
				OPTIONAL
	* 4	151007	2	GASKET, VITON
	* 4	151023	2	GASKET, EPDM
6	* 4	151026	2	GASKET, KALREZ

6	ADDED KALREZ OPT.	01/18/17	SS
5	WAS #101071	02/14/14	SS
4	ADDED PARTS	06/2008	SS
3	WAS #152035	05/13/99	SS
2	WAS #152018	05/13/99	SS
1	WAS 1/8" NIPPLE	01/23/97	SS
NO.	REVISION	DATE	BY

DRAWING	LEVELS	VIEW
2489	1,2	1
FROM SER#	DATE	TO SER#
X	X	X

TOLERANCES	
ALL DIMENSIONS ARE IN INCHES UNLESS OTHERWISE SPECIFIED.	
*TOL. DECIMALS: .XXX= +/- .005 .XX= +/- .015 .X= +/- .030	*TOL. ANGLES: +/- .5 DEGREES *CONCENTRICITY: .005 T.I.R.
*REMOVE BURRS AND BREAK EDGES .005 MIN.	

THIS PRINT IS CONFIDENTIAL AND IS THE PROPERTY OF HAMMONDS TECHNICAL SERVICES

THIS PRINT SHALL NOT BE USED, COPIED OR REPRODUCED IN WHOLE OR IN PART NOR SHALL THE CONTENTS BE REVEALED IN ANY MANNER TO ANYONE UNLESS WRITTEN PERMISSION IS OBTAINED FROM HAMMONDS TECHNICAL SERVICES.

HAMMONDS TECHNICAL SERVICES, INC.

SCALE	NTS	APPROVED BY:	SCG212	DRAWN BY	SS
DATE	07/20/93	REVISED	01/18/17		
DRAWING TITLE					
SUCTION CALIBRATION GAUGE					
MAT' L:					DRAWING NUMBER
					2489

Hammonds Model AC600-1P7 Injection Cart Manual

HAMMONDS SUCTION CALIBRATION GAUGE

CALIBRATION INSTRUCTIONS

- 1) IN ORDER TO CALIBRATE, THE PUMP MUST BE PRIMED AND PURGED OF ALL AIR. THE 3-WAY VALVE MUST BE SET TO INJECT.
- 2) WITH SUPPLY VALVE OPEN, SLOWLY OPEN VENT VALVE. THIS WILL FILL CALIBRATION GAUGE. FILL TO ZERO MARK. DO NOT OVERFILL. ONCE FULL, CLOSE VENT VALVE.
- 3) MAKE NOTE OF ADDITIVE LEVEL IN CALIBRATION GAUGE AND MAIN PRODUCT METER READING. BEGIN CALIBRATION BY FIRST CLOSING THE SUPPLY VALVE AND THEN OPENING THE VENT VALVE. START THE PRODUCT FLOW (SET FOR A SHORT TRIAL RUN).
- 4) AT THE END OF THE RUN, RECORD THE AMOUNT OF ADDITIVE THAT WAS DRAWN FROM THE CALIBRATION GAUGE. RECORD THE AMOUNT OF FUEL PUMPED. CLOSE THE VENT VALVE. OPEN THE SUPPLY VALVE.
- 5) DIVIDE THE AMOUNT OF ADDITIVE USED BY THE VOLUME OF FUEL THAT WAS PUMPED GIVING YOU PPM.
- 6) INCREASE OR DECREASE PERCENTAGE OF STROKE ON DIAPHRAGM PUMP TO OBTAIN DESIRED INJECTION RATIO.

EXAMPLE: (METRIC)
 ADDITIVE INJECTED = 500 ML
 FUEL DELIVERED = 1785 LITERS

$$\frac{500}{1785} = .280$$

$$\frac{.280}{1000} = .000280 \text{ (280 MILLIONTHS)}$$

OR 280 PPM (PARTS PER MILLION)

EXAMPLE: (US)
 ADDITIVE INJECTED = 11.5 oz
 FUEL DELIVERED = 350 GALLONS

$$\frac{11.5}{350} = .0328$$

$$\frac{.0328}{128 \text{ oz/gal}} = .000256 \text{ (256 MILLIONTHS)}$$

OR 256 PPM (PARTS PER MILLION)

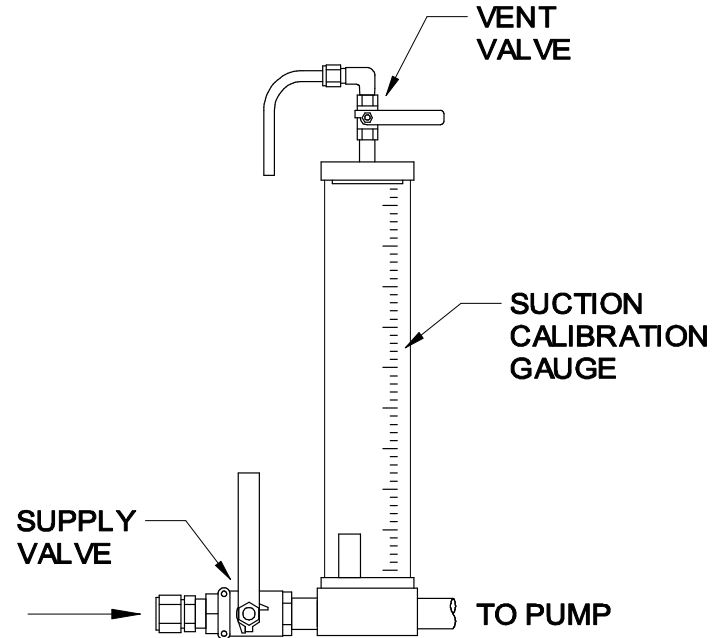

NO.	INITIAL RELEASE	04/07/93	SS	DRAWING	LEVELS	VIEW	
	REVISION			1891	1,2	1	
				FROM SER#	DATE	TO SER#	DATE
				X	X	X	X

TOLERANCES ALL DIMENSIONS ARE IN INCHES UNLESS OTHERWISE SPECIFIED.		THIS PRINT IS CONFIDENTIAL AND IS THE PROPERTY OF HAMMONDS TECHNICAL SERVICES		HAMMONDS TECHNICAL SERVICES, INC.	
*TOL. DECIMALS: .XXX= +/- .005 .XX= +/- .015 .X= +/- .030	*TOL. ANGLES: +/- .5 DEGREES *CONCENTRICITY: .005 T.I.R.	SCALE NTS	APPROVED BY:	DRAWN BY SS	
*REMOVE BURRS AND BREAK EDGES .005 MIN.		DATE 04/07/93		REVISED	
SURFACE FINISH 12/		DRAWING TITLE SUCTION CALIBRATION GAUGE			
		DRAWING NUMBER 1891			

Hammonds Model AC600-1P7 Injection Cart Manual

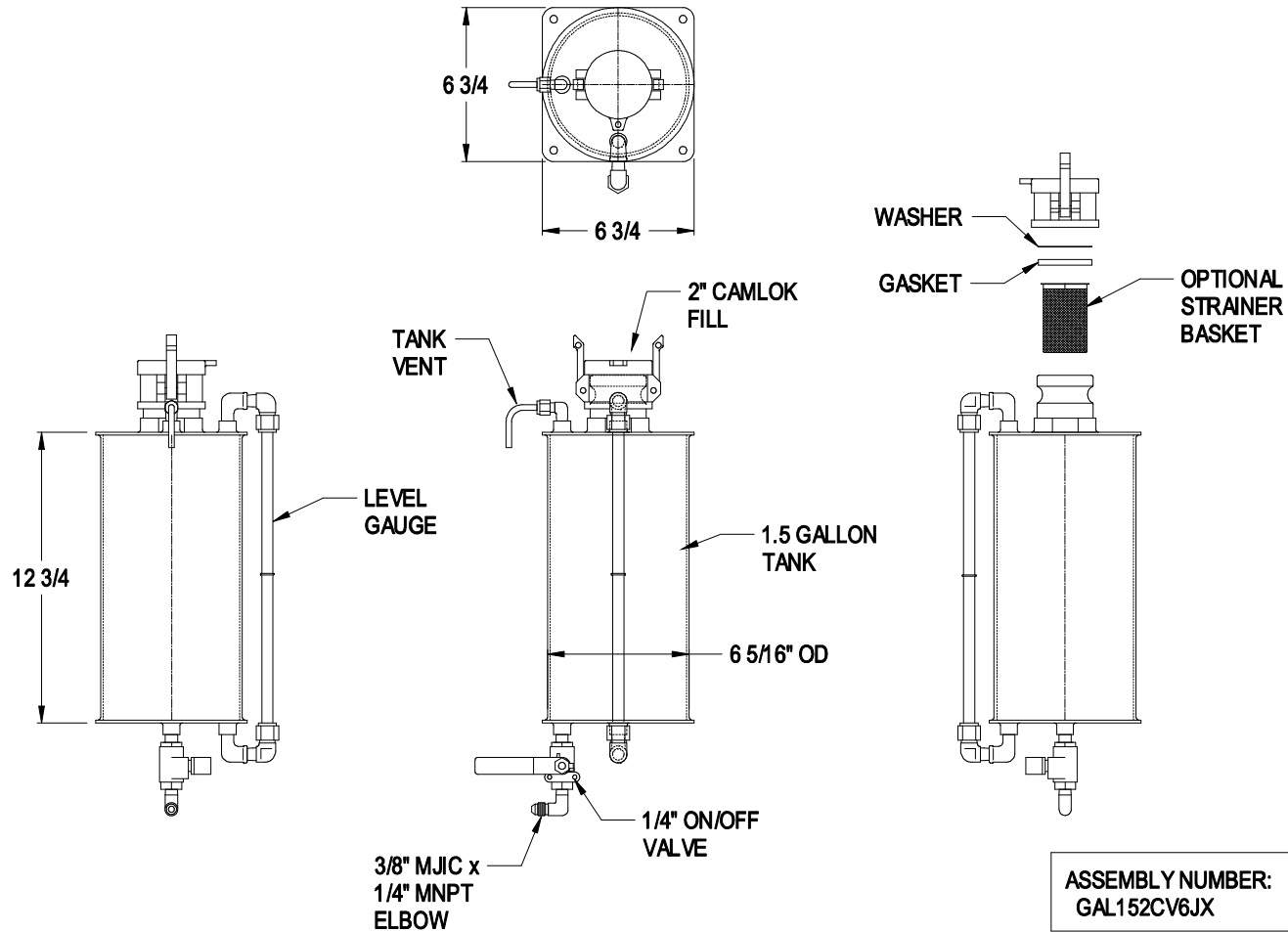

ASSEMBLY NUMBER:
GAL152CV6JX

<table border="1" style="width: 100%; border-collapse: collapse;"> <tr> <td style="width: 25%;">DRAWING</td> <td style="width: 25%;">LEVELS</td> <td style="width: 25%;">VIEW</td> <td style="width: 25%;"></td> </tr> <tr> <td>ACCART</td> <td>140, 141</td> <td>I</td> <td></td> </tr> </table>					DRAWING	LEVELS	VIEW		ACCART	140, 141	I		*TOLERANCES* ALL DIMENSIONS ARE IN INCHES UNLESS OTHERWISE SPECIFIED.		THIS PRINT IS CONFIDENTIAL AND IS THE PROPERTY OF HAMMONDS TECHNICAL SERVICES		HAMMONDS TECHNICAL SERVICES, INC.											
					DRAWING	LEVELS	VIEW																					
ACCART	140, 141	I																										
<table border="1" style="width: 100%; border-collapse: collapse;"> <tr> <td style="width: 25%;">NO.</td> <td style="width: 25%;">REVISION</td> <td style="width: 25%;">DATE</td> <td style="width: 25%;">BY</td> <td style="width: 25%;">APPVD</td> </tr> <tr> <td></td> <td></td> <td></td> <td></td> <td></td> </tr> </table>					NO.	REVISION	DATE	BY	APPVD						<table border="1" style="width: 100%; border-collapse: collapse;"> <tr> <td style="width: 25%;">FROM SER#</td> <td style="width: 25%;">DATE</td> <td style="width: 25%;">TO SER#</td> <td style="width: 25%;">DATE</td> </tr> <tr> <td>X</td> <td>X</td> <td>X</td> <td>X</td> </tr> </table>		FROM SER#	DATE	TO SER#	DATE	X	X	X	X	SCALE: NTS DATE: 03/05/14 APPROVED PART NUMBER: SEE NOTE DRAWING TITLE: 1.5 GAL TANK F/ACCART		DRAWN BY: SS REVISED: .	
NO.	REVISION	DATE	BY	APPVD																								
FROM SER#	DATE	TO SER#	DATE																									
X	X	X	X																									
					*TOL. DECIMALS: .XXX = +/- .005 .XX = +/- .015 .X = +/- .030 FRAC. = +/- 1/16		*TOL. ANGLES: +/- .5 DEGREES		THIS PRINT SHALL NOT BE USED, COPIED OR REPRODUCED IN WHOLE OR IN PART NOR SHALL THE CONTENTS BE REVEALED IN ANY MANNER TO ANYONE UNLESS WRITTEN PERMISSION IS OBTAINED FROM HAMMONDS TECHNICAL SERVICES.																			
					*CONCENTRICITY: .005 T.I.R.		*REMOVE BURRS AND BREAK EDGES .005 MIN.																					
					SURFACE FINISH: 125/		MAT'L: SS		DRAWING NUMBER: 7005																			