

**OPERATING INSTRUCTIONS
AND
MAINTENANCE MANUAL
FOR
HAMMONDS MODEL AC800-2L-1P7
FLUID POWERED
ADDITIVE INJECTOR CART**

Manufactured by:



HAMMONDS TECHNICAL SERVICES, INC.

6807 West Little York Rd.
Houston, Texas 77040

Phone: 281-999-2900

Fax: 713-896-9419

www.hammondscos.com

December 2023

Hammonds Model AC800-2L-1P7 Injection Cart Manual

TABLE OF CONTENTS

Special Notice to Users	3
Installation and Preparation for Startup	3-4
Preparation for Calibration and Startup	5
Calibration and Startup	5-8
Additive Chart	9
Trouble Shooting the System	9-10
Preventive Maintenance	10-11
Preventive Maintenance Schedule	12
Long Term Storage	12-13
Desiccant Dryer Instructions	14

Attachments:

- AC800 Cart System Layouts
- Model 800-2L-1P7 Injector Layouts
- Hydraulic Schematics
- Model 800 Driver
- Gear Reducer
- 2L Injector Pump
- Diaphragm Replacement Instructions
- 1P7 Injector Pump
- SCG412SS Suction Calibration Gauge
- Sight Flow Indicator
- SCG206 Suction Calibration Gauge
- Calibration Gauge Instructions
- Tank Assemblies
- Drum Connection / Operation
- Installing a New Drum of Additive
- Static Grounding Reel
- Fueling Nozzle

Hammonds Model AC800-2L-1P7 Injection Cart Manual

SPECIAL NOTICE TO USERS PLEASE READ CAREFULLY BEFORE OPERATING EQUIPMENT

This additive injector system is designed to give consistent dependable performance when operated and maintained according to manufacturer's recommendations. However, being a mechanical device, it is subject to failure from improper installation, wear, human error and operating environments beyond the control of the system. Because of this fact, it is the responsibility of the operator to make certain that:

1. The system is installed properly.
2. The system is being operated properly.
3. The system is actually running during product transfer.
4. The system is checked after the transfer operation to make certain the proper amount of additive was injected during the operation.

The performing of these checks by the operator eliminates the possibility of product not having the proper additive ratio as required. Therefore, since the manufacturer cannot be present during each transfer operation, the responsibility for checking the performance of the system is that of the operator. Should there be any questions whatsoever, the operator should consult the distributor from whom the unit was purchased.

DO NOT TAKE CHANCES....DO NOT GUESS....BE ABSOLUTELY CERTAIN THAT THE SYSTEM IS INSTALLED AND WORKING AS IT SHOULD.

The user/operator carries the final responsibility to make certain the system is operating properly.

INSTALLATION AND PREPARATION FOR STARTUP

In most cases, the Hammonds fluid powered injector is shipped complete and ready to operate. The system should include appropriate fittings to suit your specific application. Flow direction is marked on additive pumps and check valves.

CAUTION

DO NOT ATTEMPT TO USE THIS DEVICE WITHOUT UNDERSTANDING AND FOLLOWING PROPER SAFETY PRECAUTIONS REGARDING SYSTEM GROUNDING, FIRE SAFETY, AND SPECIAL HANDLING FOR POTENTIALLY DANGEROUS ADDITIVES.

Consult your Engineering Department for their specific instructions. Make certain all personnel involved with this system are thoroughly familiar with safe operating practices.

If your system has been purchased "bare," consult your equipment distributor for help in selecting hoses, fittings and other related accessories. Selection of materials compatibility, location of unit within the system, effect of the unit on the system and injection point of the additive are also factors that should be discussed by factory authorized personnel.

Hammonds Model AC800-2L-1P7 Injection Cart Manual

If no factory-authorized distributor is available, consult the factory directly for assistance.

POINT OF INJECTION OF ADDITIVE

Some additives may adversely affect other components in the product handling systems, for example seals in meters, valve seals, aluminum and filter elements to name a few. The Hammonds injector systems do an excellent job of mixing the additive in the product, and does not inject in large slugs. Because of this superior mixing and very small concentration of additive in any one point, many customers feel that this is not a problem. **SOME DO**, and therefore, should use their own

judgment as to the effect of these additives. **HAMMONDS TECHNICAL SERVICES, INC. CAN ONLY ADVISE YOU OF THE POSSIBLE HAZARDS.** It is up to the owner to decide his preference as to location of the additive injection point. It can be placed at any point in the system. The 800 comes with the injection point directly ahead of the fluid motor for good blending. It can be located elsewhere very easily. If the injection point is moved from the body of the injector, the 1/4" tapped hole must be plugged, the inlet check valve moved to the new location, and the injection tubing rerouted to the new location. An injection check valve must always be used regardless of location.

Hammonds Model AC800-2L-1P7 Injection Cart Manual

PREPARATION FOR CALIBRATION AND STARTUP

BEFORE ATTEMPTING TO START THE SYSTEM OR MAKE CALIBRATIONS, PLEASE READ THE FOLLOWING INFORMATION CAREFULLY.

During startup and calibration, you will be bleeding the system of air and checking for possible leaks throughout the system. Provisions should be made for collection or clean-up of spilled fluid. Attempts should be made to minimize losses during these procedures. If the additive being handled is flammable, fire safety precautions should be taken.

A WORD ABOUT ADDITIVES

Most additives being used in fuels today have at least some degree of toxicity. Many are very dangerous. Extreme caution should be taken in handling additives. Remember, the additive is placed under pressure when being injected into the line. Be careful; wear protective clothing including eye protection. Be sure you have facilities to wash off any additive that may come in contact with your skin. Read all

additive manufacturers safety precautions and Material Safety Data Sheets, following them to the letter.

HERE IS WHAT IS NEEDED:

- Appropriate safety protection equipment.
- Eye protection in the form of safety goggles.
- A marked graduated glass bottle that is marked in either cc's or ounces. (At least 16 oz.)
- A stop watch.
- A means of determining the flow rate of the main system.
- A small pocket calculator is helpful.
- A clipboard is helpful with pad of paper.
- **AT LEAST ONE AND PREFERABLY TWO HELPERS**

REMEMBER: Any plumbing system varies with temperature and fluid being pumped. The system also changes as parts of the pump wear.

CALIBRATION AND STARTUP

IF YOUR INJECTOR SYSTEM IS EQUIPED WITH CALIBRATION GAUGES, FOLLOW THE INSTRUCTIONS FOR THEIR USE IN THE BACK OF THIS MANUAL.

PROPER ADDITIVE INJECTION RATIOS

Although volumetric calibration at atmospheric pressure will bring you within an acceptable range of additive injection, the only true evaluation for

proper ratio is the ASTM D-5006 evaluation for fuel system ice inhibitor (FSII). Do not depend on volumetric calibration to ensure on-spec performance because line pressures can vary and additive injector parts wear over time. Contact Hammonds Fuel Additives, Inc. for supply of quality fuel system ice inhibitor and fuel testing procedures.

Please follow these steps in their given order. Read them over carefully before

Hammonds Model AC800-2L-1P7 Injection Cart Manual

starting. Follow them to the letter. If there is any part of the procedure that is not clear, consult your local distributor or the factory directly.

1. Make certain the additive tank/drum is at least $\frac{1}{4}$ full of the proper additive.
2. Open the suction valve between the tank and the pump. This valve should be located at any point between the additive tank and the injector.
3. All systems are calibrated at the factory to customer specified requirements. So if adjustments are required, they should only be minor. If this is the case, go directly to step 6.
4. If you are starting from scratch in the calibration and adjustment, loosen the stroke adjustment locking screws located on the bottom of the pump body directly under the stroke adjustment knob. This will allow the stroke adjustment to be moved.
5. Adjust the stroke adjustment knobs located on the pump face to approximately 50%. **CAUTION:** Do not turn these adjustments with excessive force. If they are difficult to adjust, simply rotate the main rotor shaft, by producing flow in main product line. Lock the stroke adjustment locking screws down firmly.
6. Set the calibration valve (3-way valve) in the "calibrate or bleed position." This is done by making certain that the handle on the valve

is positioned so that additive will exit through the short open tube.

7. Make certain all product connections going to and from the system are in their proper, locked position to ensure safe, leak proof flow of product through the fluid motor. Double check the flow direction arrows located on the fluid motor housing, and check valves before and after the pump to ensure that the system is installed properly.
8. At this point, consider the information you will have to gather during the next few steps of the calibration process.
 - What will the flow rate through the unit be?
 - What is the length of time that the calibration will cover?
 - What is the amount of additive in ounces or cc's that you will need to collect based on the duration of the calibration.

You should have the answer to all of these questions before your first trial run.

9. Before starting the main product flow through the system, make certain everyone understands that you will run the system for, let's say, one (1) minute. Even shorter runs are fine, especially if you are running at high flow rates.

Hammonds Model AC800-2L-1P7 Injection Cart Manual

10. Place the measured graduate under the calibration tube. Put on your eye protection.
11. At the command of the time keeper, or that person watching the flow meter, start the main product pumps.
12. Give the system a few seconds to gather momentum and flow through the fluid motor. Notice if the additive injector system is turning. The bearing on the shaft under the stroke adjustment knob cover should be spinning.
13. If the pump is being started up for the first time, it will take a few seconds to prime itself and begin discharging fluid from the calibration tube. Is your eye protection on? If not, **PUT IT ON NOW!**
14. As soon as the pump begins discharging a clear, air free stream of fluid from the calibration tube, you are ready to begin your calibration. At this point, the system is primed.
***Hammonds recommends using the Pressure Simulating Calibration Device, an optional accessory item, to duplicate system pressure during calibration.**
15. You will now prepare to make your first actual calibration run. Empty your collected additive back into the tank, putting the bottle back under the calibration tube. Notice the setting on the main product meter, set your stop watch at zero.
16. When ready, start the system again. Stop it at the decided time interval or meter reading. Calculate the amount of product that traveled through the system. Measure the amount of additive gathered, and record the amount of elapsed time.
17. It will be at this time that you will have to calculate how much additive you should have collected for the amount of fuel that the system pumped. This, of course, depends upon the ratio that is required. The following example is the easiest way of explaining the procedure without getting too complicated. It is not the only way...use it if you like.

Example condition:

- Amount of product pumped: 500 gallons
- Ratio of additive desired: 250 PPM (Parts per million)

It is assumed that the operator will know how much product is being pumped through the system in a given length of time. If, for example, you have a meter that registers the flow in gallons, you simply record the gallons at the beginning of the timed run, and then again at the end of the run. If you run for one (1) minute, you simply subtract the beginning number on the meter from the number registered after the run. This will give you the gallons per minute (GPM). Having to make this calculation is the only reason for timing the run. You can accomplish the same result by just watching the meter and stopping the system when you have totaled the desired amount of gallons through the system. In any case, you must know the amount of product passing through the system before calibration can begin.

- Change the gallons pumped into ounces by multiplying total gallons

Hammonds Model AC800-2L-1P7 Injection Cart Manual

(in our example 500) by 128 (128 oz. to a gallon). The answer is 64,000 ounces.

- Divide by 1,000,000. The answer is .06. Since you are dealing in 1/1,000,000 (one part per million) of the total for your ratio, you must find out what 1/1,000,000 of the 500 gallons is, .06 ounces is 1/1,000,000th (one part per million) of 500 gallons.
- Multiply the .06 x 250 (for 250 PPM ratio). **The answer is 15 ounces.**

You should collect 15 ounces of additive for every 500 gallons of fuel pumped.

These are all large, round numbers. You may, for example, only be running at 100 GPM, not 500. Use the same procedure; just change the numbers to fit your application.

No two systems will ever perform exactly the same. For this reason, the procedures given for calibration are general in nature. Obviously, it is impossible to provide a graph or table that would be absolutely accurate in every case. With that in mind, all tables and graphs should be used as general guidelines. Remember, the calculated, timed and measured output that you gather is absolute. Trust your figures and your calculations.

NORMAL OPERATION

Following initial start-up and calibration, the system requires very little attention other than making certain that additive tank levels are

maintained. Operators will quickly become accustomed to the performance of the system by observing the Calibration Gauge glass or Sight Flow Indicator. On-spec injection will cause a certain response in the indicators, and with some practice, operators will be able to observe the system at a glance. *This does not mean that system calibration should not be periodically checked!* However, during a busy workload, these visual checks will provide assurance to the operator that the system is functioning.

Assuming the system remains set up and operating at least intermittently, calibration is required perhaps every 1 – 3 months. Good record keeping of additive inventory and use levels compared to fuel handled can give a good indication that additive is on specification. Test such as the refractometer for FSII content should be the final test to verify additive injection ratios.

Hammonds Model AC800-2L-1P7 Injection Cart Manual

SAMPLE ADDITIVE CHART

GALLONS	135 PPM	270 PPM	1000 PPM
100	1.7 OZ.	3.4 OZ.	12.8 OZ.
200	3.4 OZ.	6.9 OZ.	25.6 OZ.
400	6.9 OZ.	13.8 OZ.	51.2 OZ.
500	8.6 OZ.	17.2 OZ.	64.0 OZ.
700	12.0 OZ.	24.0 OZ.	89.6 OZ.
1000	17.2 OZ.	34.5 OZ.	128.0 OZ.

TROUBLESHOOTING THE SYSTEM

The following conditions are given as a means of troubleshooting the system. Each condition lists a number of possible causes. In most cases, trouble can be solved by the use of this section. Please read it carefully before attempting repairs or making changes in the system.

FLUID MOTOR IS NOT TURNING

- Insufficient flow to turn the motor. A minimum flow of about 75 GPM is needed to start the system.
- A rag or some other object is jammed in the line preventing the fluid motor from turning.
- A diverter valve is blocked downstream of the system, blocking the fuel flow through the system.
- A valve is closed upstream of the fluid motor starving the product flow.
- If the unit has been recently serviced internally, or it is new, the rotor might be installed backwards. Consult the factory before disassembly.

INJECTOR IS TURNING AND PUMP IS RUNNING, BUT WITH NO OUTPUT

- Pump is air-locked. In some cases where there is a very long line running from the injector head and the point of injection into the system, there is sufficient air volume to cause the pump to act as a compressor. It is not able to open the valves throughout the system and therefore, cannot pull a suction of fluid to the pump. Loosen the connection at the injection point check valve and allow it to remain open until the pump begins pumping. This is rare, but can happen in some cases of unusual installations.
- One or more of the suction or discharge check valves are not working. While the pump is running, tap on the side of the valves, one at a time. This will generally jar them loose. The poppet/seal is very small, and will sometimes become stuck. After the valve is loosened and has a supply of fluid, usually it will not stick again.
- The pump is not getting additive. Check the valve between the pump

Hammonds Model AC800-2L-1P7 Injection Cart Manual

and the tank. Check all connections in the line between the pump and the tank.

- The vent on the tank is not open causing the pump to pull a vacuum. Open the vent. Check to see if the cap has been removed from the dryer cartridge, if so equipped.
- The pump stroke is set at zero. Check to see if the locking screws have been left loose, allowing the adjustment knobs to rotate to zero percent (0%) of stroke.
- The additive tank/drum is empty...don't laugh, it happens.

THE INJECTOR IS OPERATING BUT WITH REDUCED OUTPUT

- Leaking suction line or trash in discharge check valve.
- Air leak in suction side of system.

- Defective tubing or piping on suction side.
- Leaks in threaded connections - suction side.
- If so equipped, a relief valve on injector may be bleeding part of the output back to suction. Relief valve may not be working, or retaining nut may have vibrated loose causing valve to fail entirely, bleeding output back to suction.
- Injector diaphragm may be pulled out in back causing injector to pump in forward portion of stroke only. This will not create a visible leak but will reduce output by 50%. It usually happens after many hours of operation.
- Fluid motor vanes are badly worn. This would only be probable after a very high number of hours of operation.

PREVENTIVE MAINTENANCE

1. Make certain to use only clean, fresh additive that has been stored in a sealed container. Most additives are moisture sensitive. Some will form heavy crystals if allowed to accumulate moisture. These crystals will stop the pump in very short order, if not cause calibration to be changed due to clogging of the valves and other parts.
2. Check the additive filter screen at least every six months. More often if there is an indication of possible contamination.
3. Check the system for leaks at every use. This is an extremely important

safety procedure, since some additives are flammable, caustic and corrosive.

4. Check for leaks from the seal that is located at the exit point of the injector output shaft in the side plate housing. This should be done at each operation. Leakage at this point usually indicates that the mechanical seal inside the rotor housing is leaking. A leak here will be fuel, and is not only dangerous from a fire standpoint, but will quickly ruin the bearings on the rotor shaft, since all lubricant will be washed away.

Hammonds Model AC800-2L-1P7 Injection Cart Manual

5. Check the fittings for leakage around the Calibration Gauge or Sight Flow Indicator, if one is used on the pump. Check this fitting each time the filter is changed or cleaned. Make certain there are no leaks in the suction line. A very small leak will either change the operation of the pump or prevent it from operating all together.
6. Visually check around the pump head and make certain there is no leaking of additive around the fluid ends. If there is, check the tightness of the head bolts. (40 inch pounds each)
7. Check the grease around the eccentric drive bearing in the pump every 6 months. Use a good quality white lithium spray lubricant.
8. It is recommended that the injector diaphragm or plunger o-ring be changed at least every 12 months. Every 6 months under extreme operating conditions. Doing so will

prevent unexpected failures and unscheduled downtime.

Hammonds injectors are very dependable. When installed properly and sized appropriately to the application, they require very little maintenance. Remember; keep the additive clean, and the suction strainer clean. If you have problems with the pump working, it is usually in the suction side of the system (between the injection pump and the additive tank). Suction lines and fittings are notorious for leaking just enough to prevent the system from working. Always check to ensure optimum suction conditions should problems occur.

Remember, a leak in the suction allows air from the outside to be introduced into the system. It does not always mean a visible leak of additive. If the pump loses its prime or output is erratic, chances are good that there are problems in the suction side. Otherwise, if it is working...leave it alone!!!!

Hammonds Model AC800-2L-1P7 Injection Cart Manual

PREVENTATIVE MAINTENANCE SCHEDULE

NOTE: It is important to read the previous pages on preventative maintenance. These intervals are general, and may vary according to individual applications and severity of service.

SERVICE FUNCTION	0-4 HRS DAILY	5-8 HRS DAILY	8+HRS DAILY
Check additive filter screen	Monthly	Monthly	Monthly
Check system for additive/fuel leaks	Daily	Daily	Daily
Inspect diaphragms/plunger seals	12 Months	6 Months	3 Months
Replace diaphragms/plunger seals	12 Months	As needed	As needed
Check eccentric bearing grease	6 Months	3 Months	Monthly
Check stroke adjustment parts for looseness	Monthly	Monthly	Monthly
Replace stroke adjustment parts	24 Months	As needed	As needed
Disassemble and inspect turbine housing and internal parts	24 Months	12 Months	8 Months
Grease bearings	12 Months	6 Months	3 Months

LONG TERM STORAGE

Hammonds Fluid Powered Additive Injection Systems are designed with long life and dependability in mind. It is unavoidable in some instances or applications that these units may sit idle for extended periods of time. Other applications may remain in storage in factory new condition for an extended period before being installed. If the application should require long periods of idle time between usage or long periods of storage prior to installation or while being moved from one installation to another, additional precautions should be taken to ensure that the systems are stored properly.

As with any fluid handling system, fluid motors and additive pumps have elastomeric seals in them that, with regular use can provide an extremely long service life. Elastomeric seals that are regularly exposed to fuel or additive during normal use remain flexible and compliant for a very long time. Long term storage can have a negative effect on elastomeric seals such as o-rings and mechanical seal components simply due to inactivity because the seal component is not regularly lubricated by the fuel or additive. Some additional steps should be taken when possible to increase the service life of the injection system with minimal maintenance required during the storage period.

Hammonds Model AC800-2L-1P7 Injection Cart Manual

LONG TERM STORAGE OF INSTALLED SYSTEMS:

Definition: A system installed in its normal operating environment with use intervals exceeding 60 days between TYPICAL operations.

Storage limitation: Indefinite

It is recommended that if a system is to be installed but only used intermittently, that the following precautions be taken:

- Circulate fuel through the system on a monthly basis to keep mechanical seals lubricated and fuel fresh in the system.
- Keep additive levels in the additive tank(s) at a low level to ensure that the additive pumps are not run dry during storage.
- Ensure that any additive remaining in the additive tank(s) does not expire due to shelf life recommendations by the additive manufacturer. If the additive reaches its shelf life recommendation, drain the additive from the tank and replace with fresh additive.
- Ensure that all service ports and vents are closed.
- Ensure that desiccant dryers, if utilized on the additive tank vents, are kept in operational condition and are fully functional at all times.

LONG TERM STORAGE OF FACTORY NEW SYSTEMS OR SYSTEMS STORED IN A WAREHOUSE OR CRATED:

Definition: A factory new system that is being stored prior to initial installation or a system that has been removed from service for long term storage.

Storage limitations: Up to 24 months in uncontrolled environmental conditions. This timeframe can be extended up to 36 months if stored in climate controlled conditions.

Generally, mechanical seal assemblies can be stored satisfactorily for this period, provided manufacturers' installation and shut down procedures have been followed. Storage procedures include:

- Drain all product and flush fluid from the equipment and seal chamber prior to long term storage. Factory new equipment will be flushed and drained prior to shipment.
- Cover all equipment openings including pump suction, discharge connections, vent valve ports, etc.
- Make provisions to ensure that equipment is protected from the direct elements (rain, wind, excessive direct sun exposure).
- IF REMOVED FROM SERVICE FOR LONG TERM STORAGE:
 - Ensure that all additive is removed from additive tanks and pump systems.
 - Ensure that all service ports and vents are closed.

Hammonds Model AC800-2L-1P7 Injection Cart Manual

DESICCANT DRYER

Your Hammonds Additive Injector Cart includes 1 or more additive tanks or a drum. These tanks may come equipped with a desiccant dryer cartridge. These dryers come in several different sizes.

Most systems are equipped with the standard 3/4" cartridge. This unit is attached to the tank via a short length of black rubber hose. The cartridge has a housing constructed of a clear poly material and is filled with a blue colored desiccant crystal. All these units are shipped from the factory with a small yellow cap on the each end of the cartridge.

Some systems may come equipped with a large canister measuring approximately 2" diameter and 10" in length. These units perform the same function, just on a larger scale. Due to their greater capacity, they last longer between service intervals. These units are sealed from the factory by a small, plastic plug which is located either on the bottom or one side of the canister.

The purpose of all desiccant dryers is simply to remove moisture from the air as the system breathes. All tanks or portable sources of additive supply must be vented to atmosphere in order for the injector to operate. If moisture in this venting air is not removed, some additives are either ruined or seriously damaged. Fuel system icing inhibitor (FSII), for example, is designed to seek out water in a fluid. So, when enough moisture is absorbed into the container, the FSII is diluted and at some point will be ruined. Biobor® JF, an anti-fungal material, will form crystals in the presence of moisture and not only perform

unsatisfactorily as an additive, but will stop up pumps and lines as well.

The following instructions apply to all desiccant cartridges:

- A. Remove the caps or plugs when the system is placed into service.
- B. Observe the color of the desiccant. The original color is blue. As moisture is absorbed, the color will change to pink. When the cartridge is completely pink, it should either have its contents removed, dried and replaced, or the entire unit replaced.

C. NOTE: The contents can be removed from plastic container, placed on a pan and baked at 400°F in a conventional oven until the moisture has been removed. When the color blue returns, the cooled material may be reinstalled into plastic containers and is again ready for service.

- D. Color change and cartridge life is totally dependent on humidity. The more moist the air, the shorter the life. Keeping it dry is especially important if additive is not consumed rapidly. Check daily and service as needed.

Hammonds Model AC800-2L-1P7 Injection Cart Manual

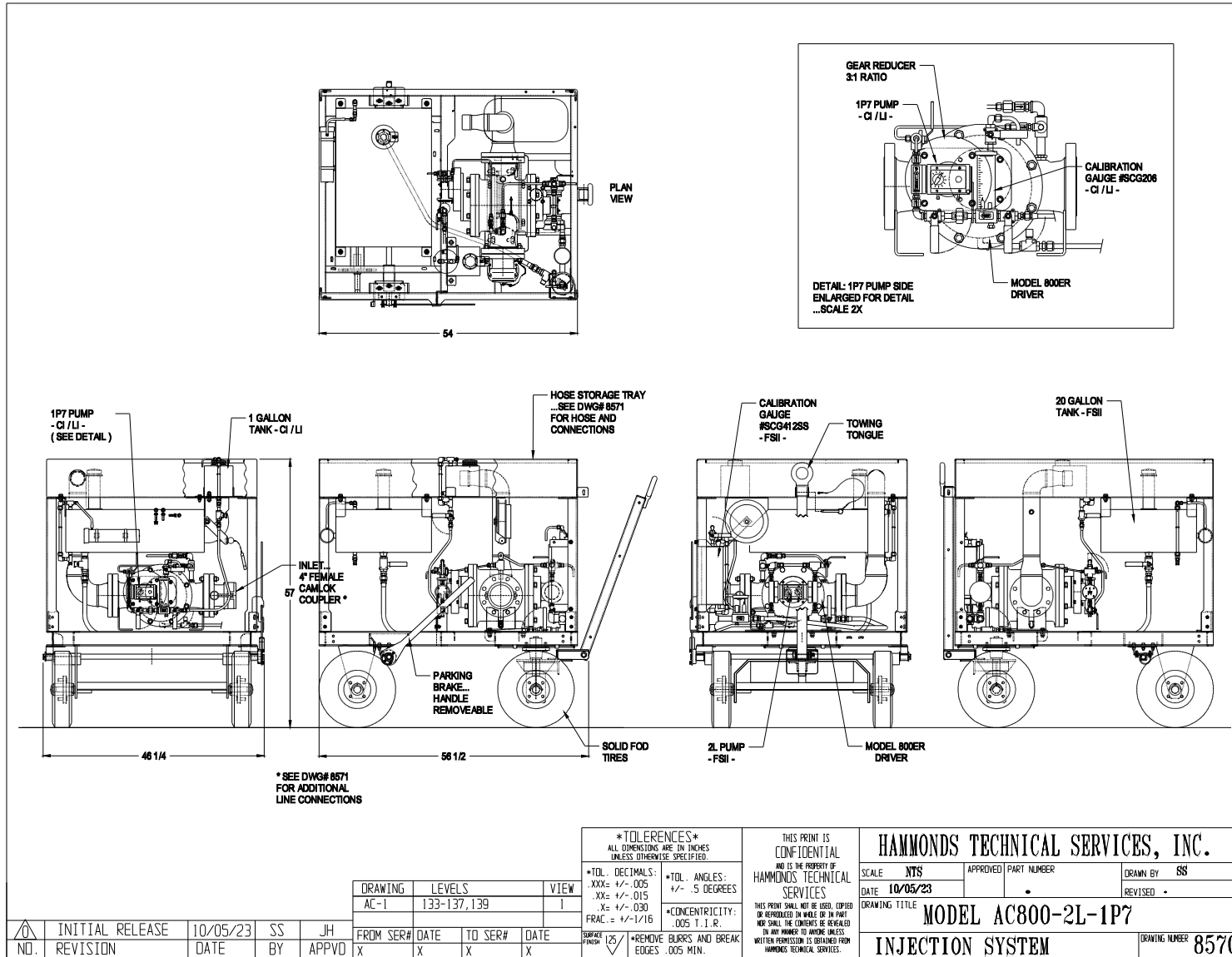

Hammonds Model AC800-2L-1P7 Injection Cart Manual

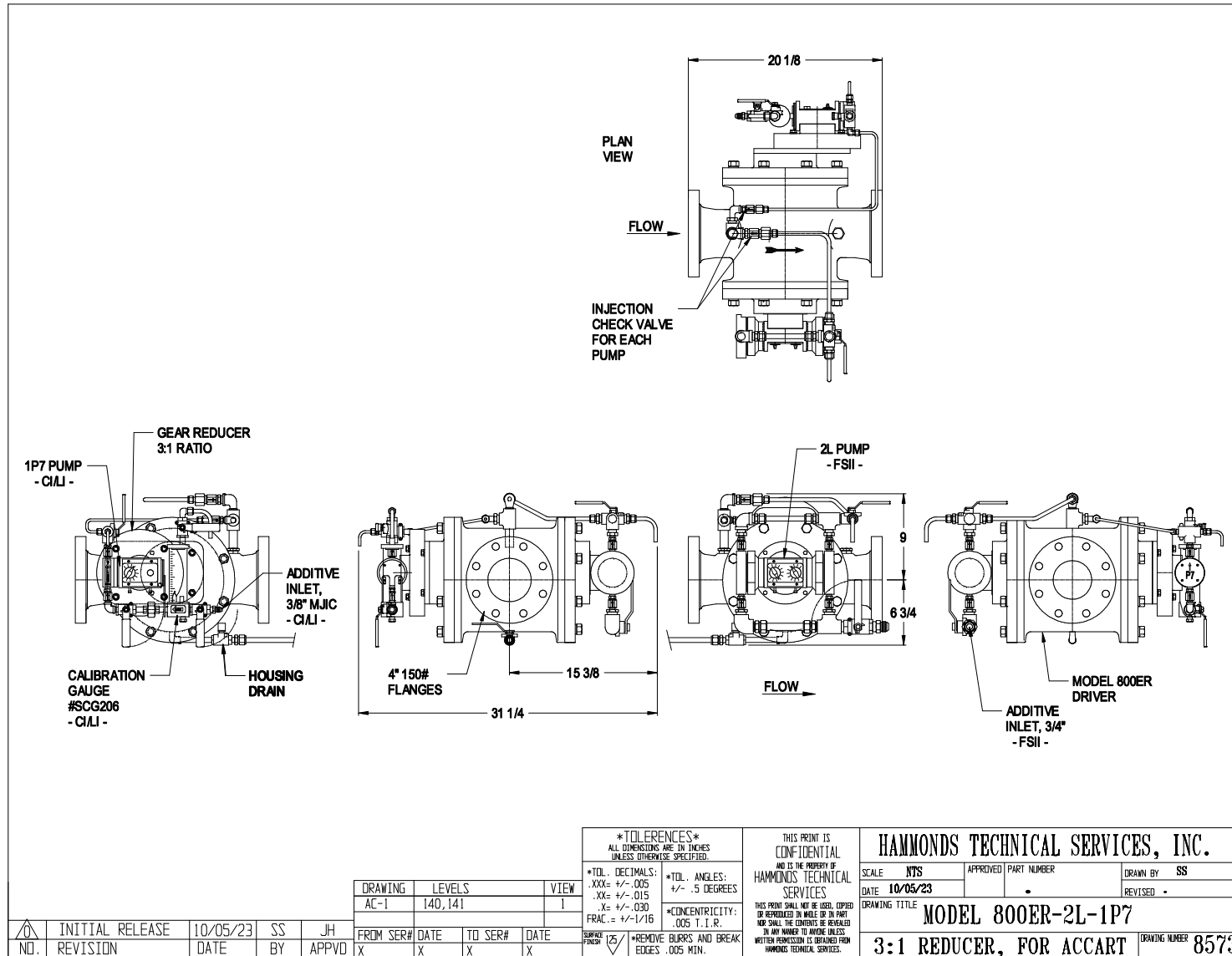

Hammonds Model AC800-2L-1P7 Injection Cart Manual

0	INITIAL RELEASE	10/06/23	SS	JH
NO.	REVISION	DATE	BY	APPVD

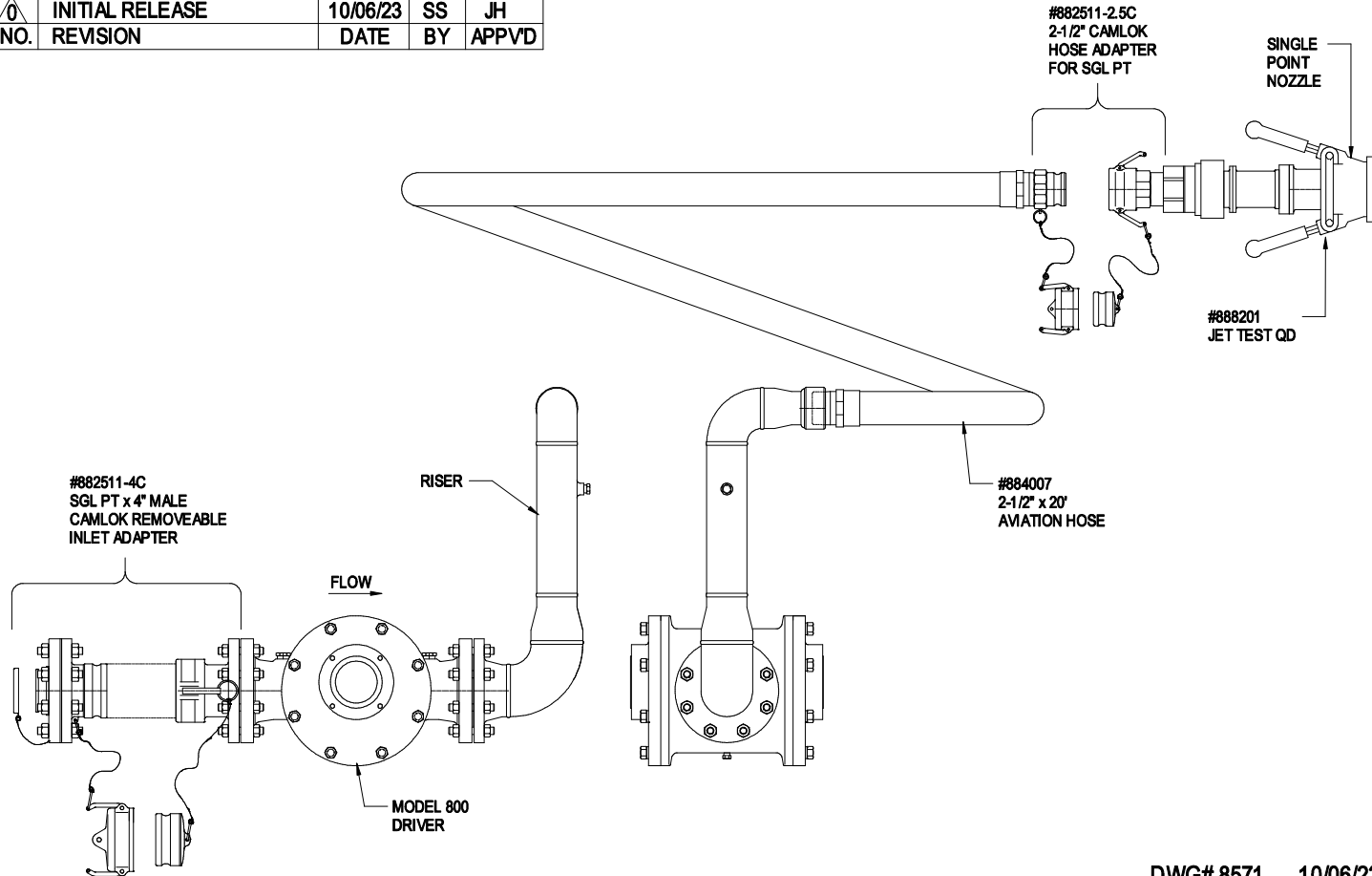

DWG# 8571 10/06/23
 ADDITIONAL LINE
 CONNECTIONS
 (AC-1 138)

Hammonds Model AC800-2L-1P7 Injection Cart Manual

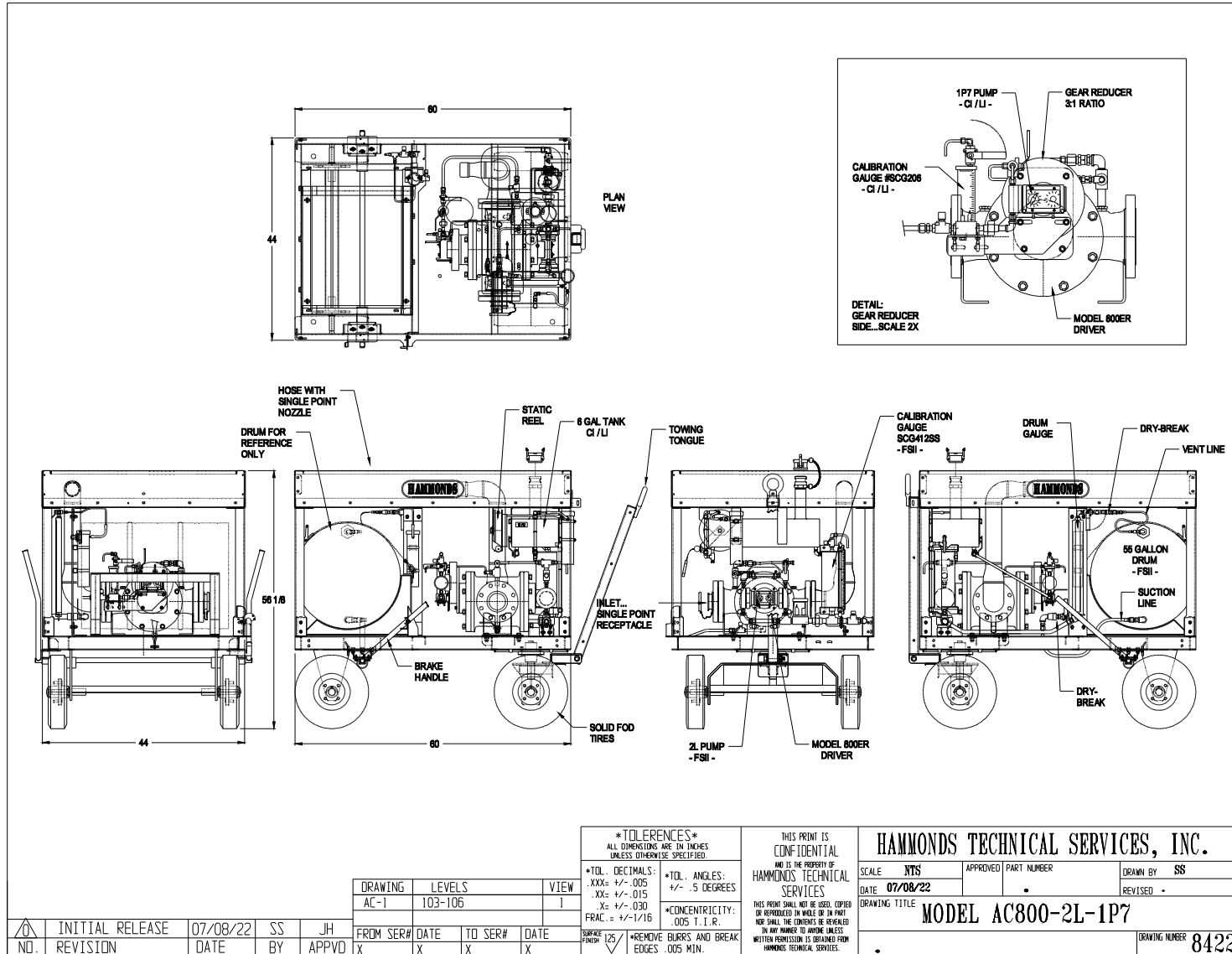

Hammonds Model AC800-2L-1P7 Injection Cart Manual

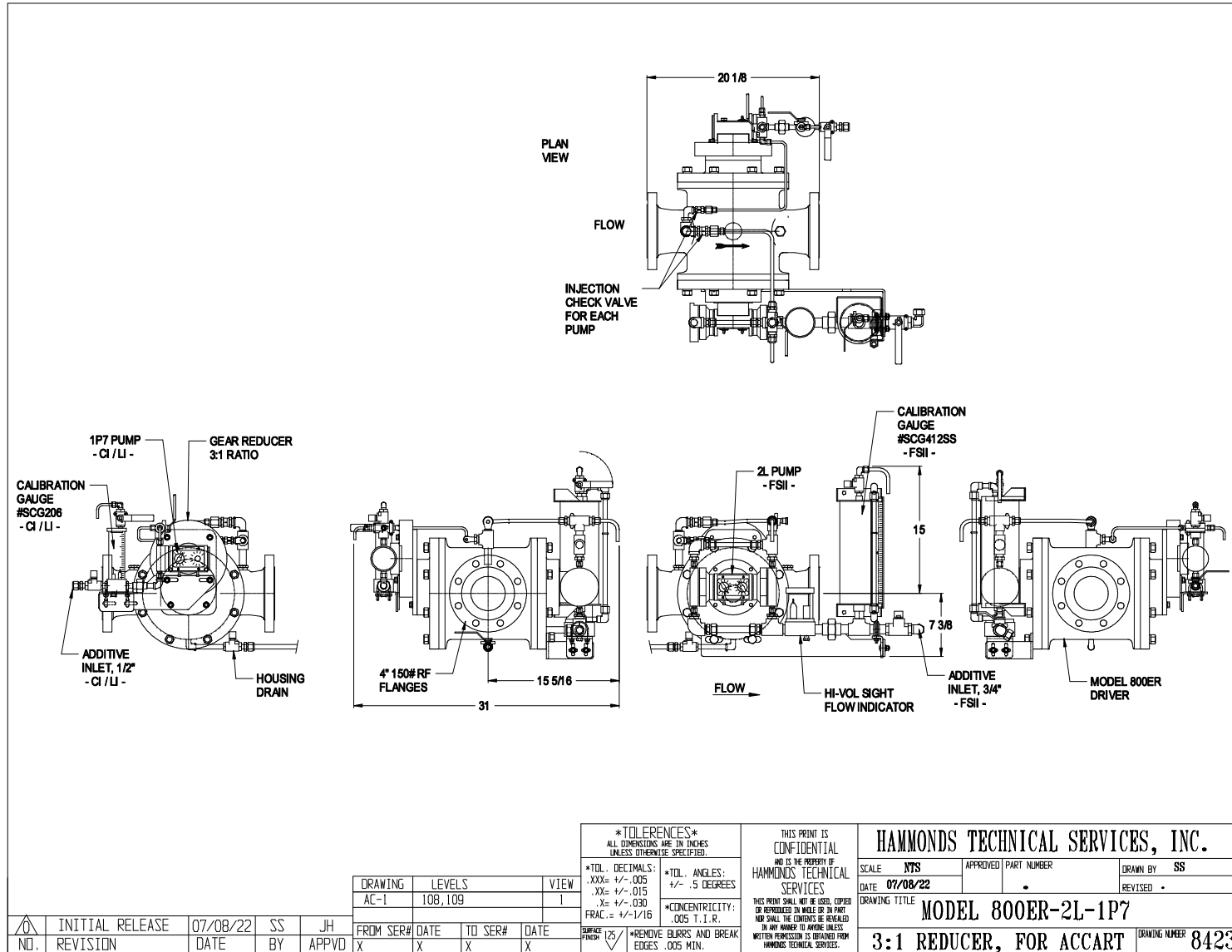

Hammonds Model AC800-2L-1P7 Injection Cart Manual

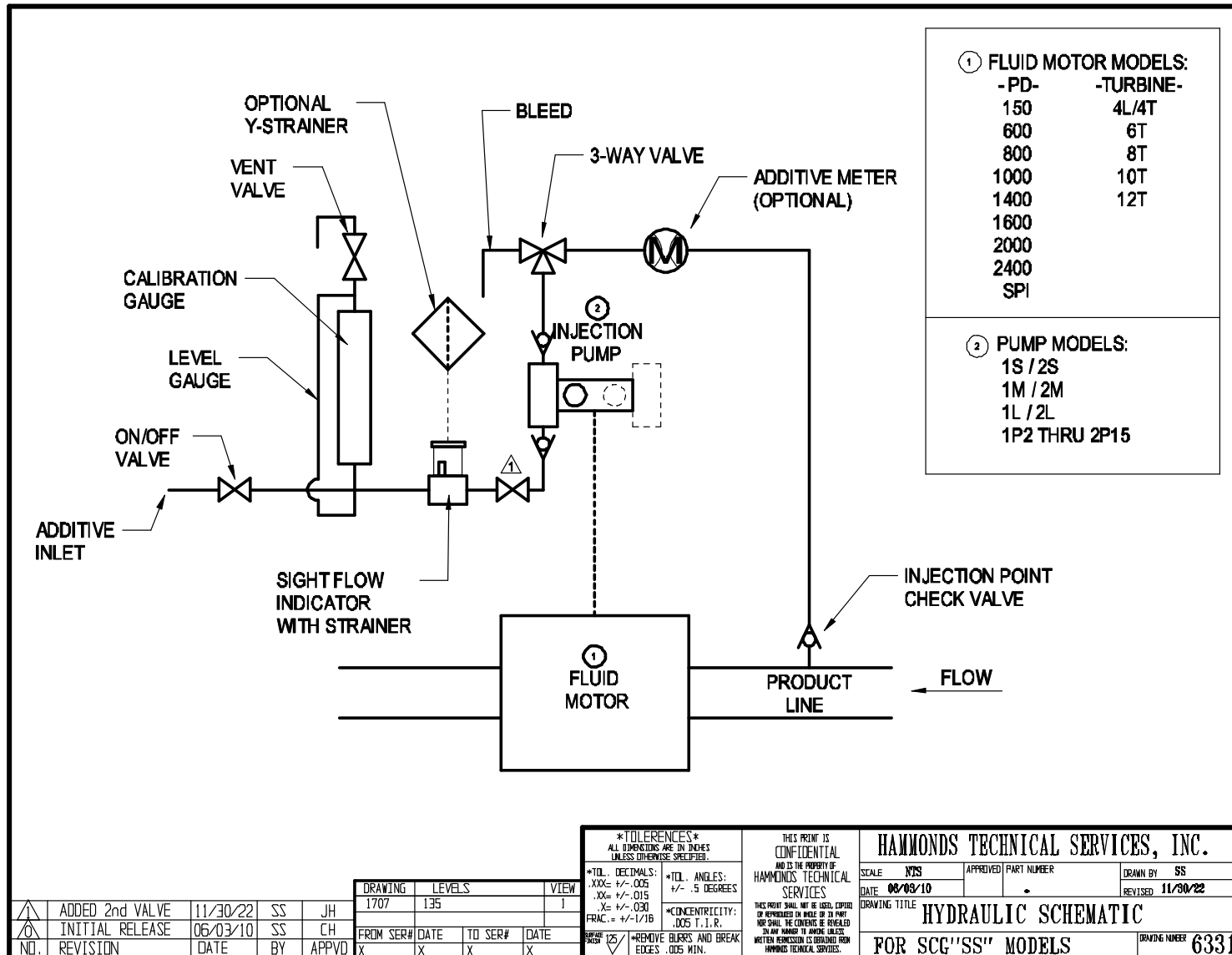

Hammonds Model AC800-2L-1P7 Injection Cart Manual

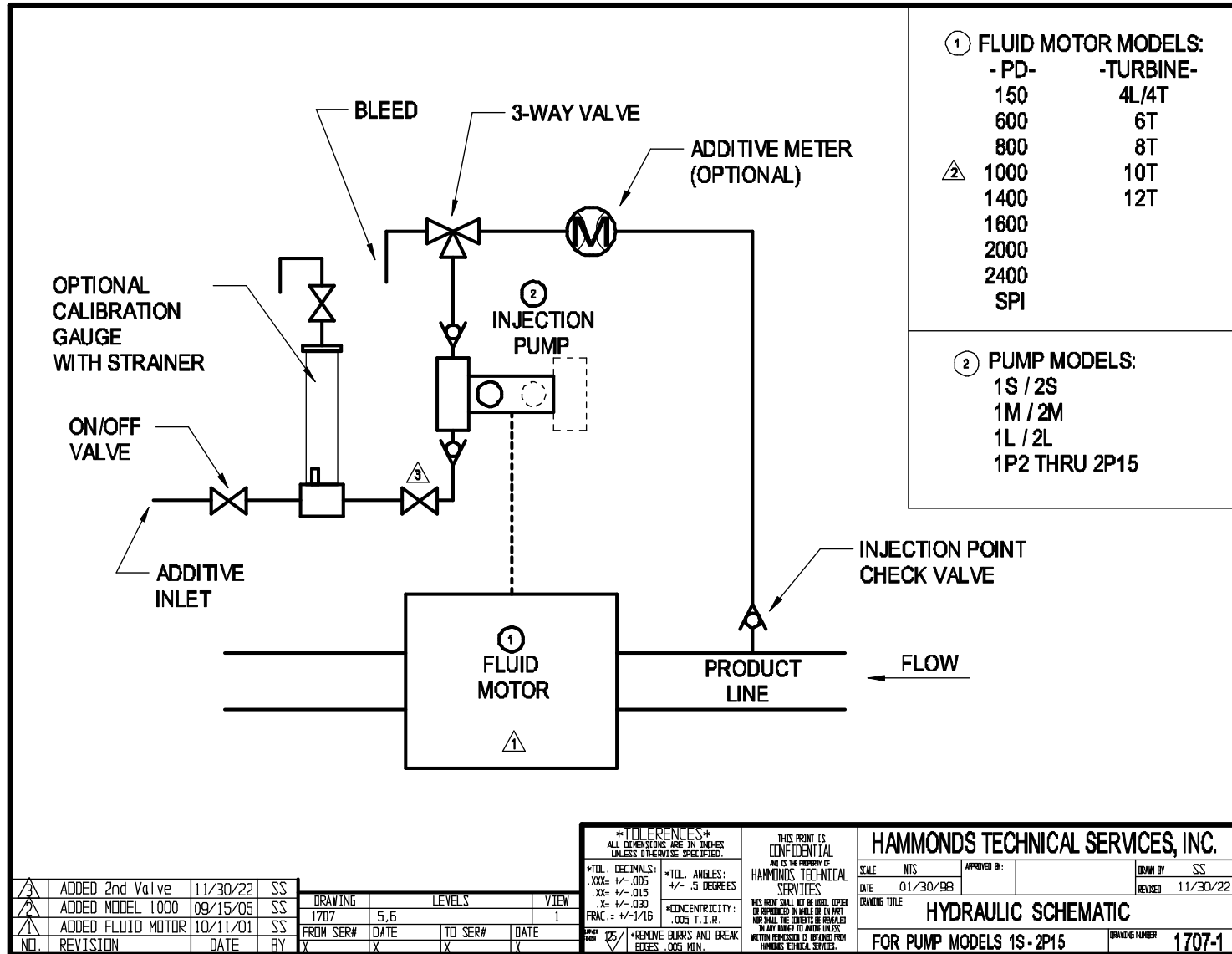

Hammonds Model AC800-2L-1P7 Injection Cart Manual

ITEM	PART NO.	QTY.	DESCRIPTION
1	184038	1	HOUSING, ALUMINUM
2	184186	1	ROTOR, 7 VANE
3	184081	1	SHAFT, ER (SINGLE ECC.)
4	184083	2	END PLATE
5	141036	2	MECHANICAL SEAL, STD.
	141023	2	MECHANICAL SEAL, HP (OPT)
6	103383	2	WAVE SPRING WASHER
7	881623	2	BEARING
8	184004	2	THRUST WASHER
9	103381	2	SNAP RING
10	103409	2	O-RING, VITON
11	881621	16	BOLT, 5/8-11 x 2"
	886319	16	BOLT, 5/8-11 x 2", SS
12	882076	16	LOCK WASHER, 5/8"
	886325	16	LOCK WASHER, 5/8", SS
13	184167	2	WEAR RING
14	184081-01	2	KEY, 1/4" SQ. x 1"
15	184011	7	VANE, TEFLON
16	151005	1	1/4" PIPE PLUG
17*	271249	1	3/4" PIPE PLUG
18*	271113	1	3/4 x 1/4 RED. BUSHING
19	184037	1	BEARING CAP
20	881882	1	BEARING
21	881999	1	SPACER
22	881157	1	H.D. DRIVE BEARING
23	101045	1	SNAP RING
24	101749	2	1/8" FILTER (OPTIONAL)
	101749-SS	2	1/8" FILTER, SS (OPTIONAL)
25	882215	2	PIN, DOWEL
26	882125	1	SHAFT COVER (OPT)
27	881083	4	3/8" LOCKWASHER (OPT)
	881711	4	3/8" LOCKWASHER, SS (OPT)
28	881084	4	3/8 x 1" HEX BOLT (OPT)
	881709	4	3/8 x 1" HEX BOLT, SS (OPT)

* OPTION..
IF ITEM #18 QTY IS 2, THEN ITEM #17 QTY IS 0

<table border="1" style="width: 100%; border-collapse: collapse;"> <tr><td>△</td><td>ADDED SS HARDWARE</td><td>10/03/22</td><td>SS</td><td>JH</td></tr> <tr><td>△</td><td>ADDED SHAFT COVER</td><td>07/26/16</td><td>SS</td><td>X</td></tr> <tr><td>△</td><td>ADDED OPTION NOTE</td><td>05/21/14</td><td>SS</td><td>X</td></tr> <tr><td>△</td><td>ADDED DOWEL PIN</td><td>12/28/11</td><td>SS</td><td>X</td></tr> <tr><td>△</td><td>INITIAL RELEASE</td><td>05/20/04</td><td>SS</td><td>X</td></tr> <tr><td>NO.</td><td>REVISION</td><td>DATE</td><td>BY</td><td>APPVD</td></tr> </table>	△	ADDED SS HARDWARE	10/03/22	SS	JH	△	ADDED SHAFT COVER	07/26/16	SS	X	△	ADDED OPTION NOTE	05/21/14	SS	X	△	ADDED DOWEL PIN	12/28/11	SS	X	△	INITIAL RELEASE	05/20/04	SS	X	NO.	REVISION	DATE	BY	APPVD		<table border="1" style="width: 100%; border-collapse: collapse;"> <tr><td>DRAWING</td><td>LEVELS</td><td>VIEW</td></tr> <tr><td>800DRVR</td><td>250,251</td><td>1</td></tr> </table>	DRAWING	LEVELS	VIEW	800DRVR	250,251	1	<table border="1" style="width: 100%; border-collapse: collapse;"> <tr><td>FROM SER#</td><td>DATE</td><td>TO SER#</td><td>DATE</td></tr> <tr><td>X</td><td>X</td><td>X</td><td>X</td></tr> </table>	FROM SER#	DATE	TO SER#	DATE	X	X	X	X	<p>*TOLERANCES* ALL DIMENSIONS ARE IN INCHES UNLESS OTHERWISE SPECIFIED.</p> <p>*TOL. DECIMALS: .XXX± +/- .005 .XX± +/- .015 .X± +/- .030 FRAC. ± +/- 1/16</p> <p>*TOL. ANGLES: +/- .5 DEGREES</p> <p>*CONCENTRICITY: .005 T.I.R.</p> <p>*REMOVE BURRS AND BREAK EDGES .005 MIN.</p>	<p>THIS PRINT IS CONFIDENTIAL AND IS THE PROPERTY OF HAMMONDS TECHNICAL SERVICES</p> <p>THIS PRINT SHALL NOT BE USED, COPIED OR REPRODUCED IN WHOLE OR IN PART UNLESS THE CONTENTS BE REVEALED IN WRITING PERMISSION IS OBTAINED FROM HAMMONDS TECHNICAL SERVICES.</p>	<p style="text-align: center;">HAMMONDS TECHNICAL SERVICES, INC.</p> <table border="1" style="width: 100%; border-collapse: collapse;"> <tr><td>SCALE</td><td>NTS</td><td>APPROVED</td><td>PART NUMBER</td><td>DRAWN BY</td><td>SS</td></tr> <tr><td>DATE</td><td>05/20/04</td><td></td><td>807ER</td><td>REVISED</td><td>10/03/22</td></tr> <tr><td colspan="6">DRAWING TITLE</td></tr> <tr><td colspan="6" style="text-align: center;">MODEL 800ER DRIVER (ALUM)</td></tr> <tr><td colspan="5">7 VANE ROTOR</td><td>DRAWING NUMBER</td><td>4864</td></tr> </table>	SCALE	NTS	APPROVED	PART NUMBER	DRAWN BY	SS	DATE	05/20/04		807ER	REVISED	10/03/22	DRAWING TITLE						MODEL 800ER DRIVER (ALUM)						7 VANE ROTOR					DRAWING NUMBER	4864
△	ADDED SS HARDWARE	10/03/22	SS	JH																																																																													
△	ADDED SHAFT COVER	07/26/16	SS	X																																																																													
△	ADDED OPTION NOTE	05/21/14	SS	X																																																																													
△	ADDED DOWEL PIN	12/28/11	SS	X																																																																													
△	INITIAL RELEASE	05/20/04	SS	X																																																																													
NO.	REVISION	DATE	BY	APPVD																																																																													
DRAWING	LEVELS	VIEW																																																																															
800DRVR	250,251	1																																																																															
FROM SER#	DATE	TO SER#	DATE																																																																														
X	X	X	X																																																																														
SCALE	NTS	APPROVED	PART NUMBER	DRAWN BY	SS																																																																												
DATE	05/20/04		807ER	REVISED	10/03/22																																																																												
DRAWING TITLE																																																																																	
MODEL 800ER DRIVER (ALUM)																																																																																	
7 VANE ROTOR					DRAWING NUMBER	4864																																																																											

Hammonds Model AC800-2L-1P7 Injection Cart Manual

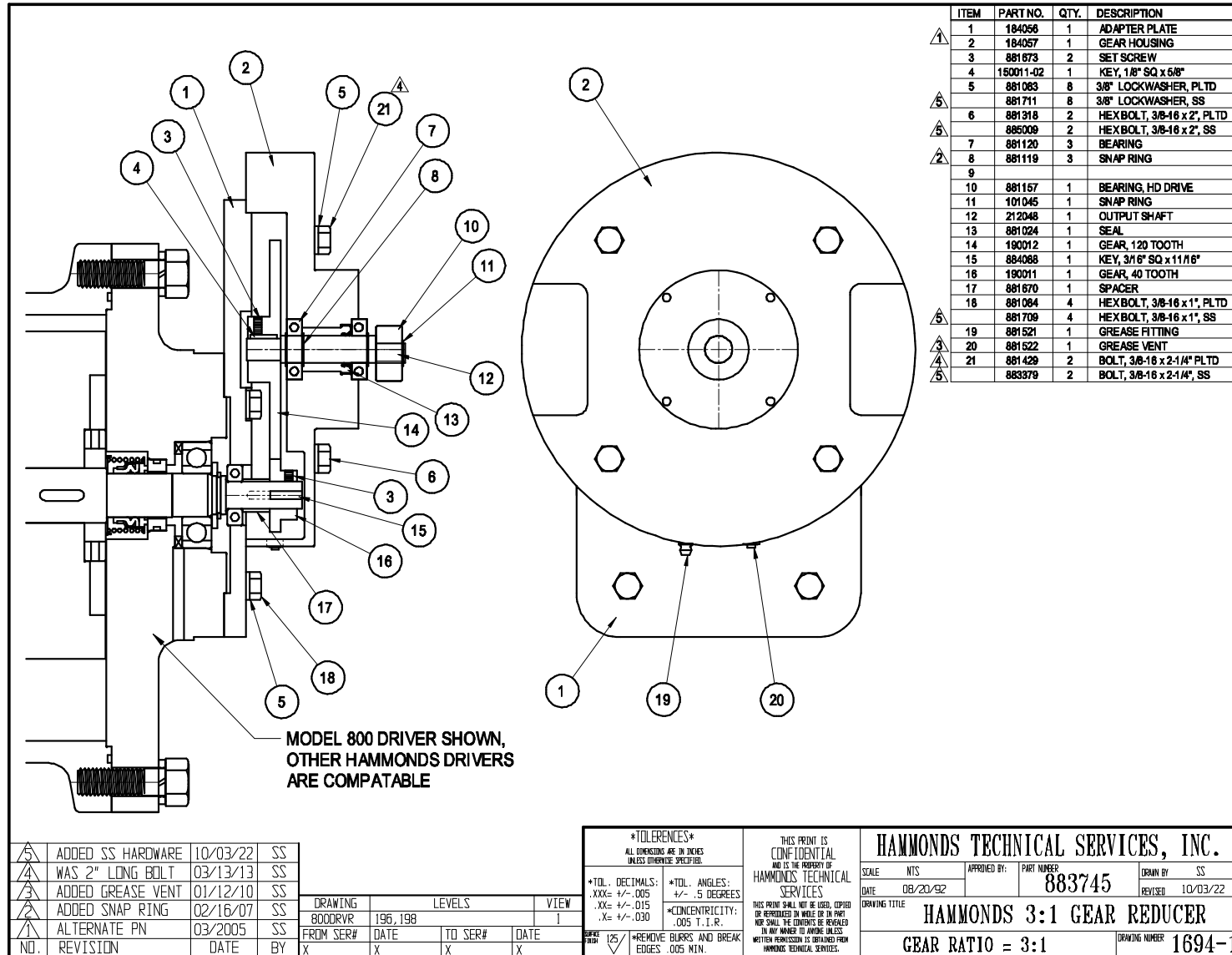

Hammonds Model AC800-2L-1P7 Injection Cart Manual

1

NOTE: MARK STROKE SETTING BEFORE REMOVING ANY PART

1 REMOVE LOCK SCREW

2 REMOVE ADJUSTMENT KNOB

3 REMOVE STROKE INDICATOR PLATE AND CAM GUIDE / COVER

4 REMOVE SCREWS HOLDING FLUID END. REMOVE FLUID END.

FLUID END

2

5 PRESS DIAL KNOB BACK ON AND ROTATE COUNTER CLOCKWISE UNTIL DIAPHRAGM HAS CLEARED SURFACE OF ADAPTER RING AND CROSSHEAD HAS CLEARED DRIVE BEARING.

6 REMOVE SNAP RING

7 SLIDE DRIVE BEARING OFF

8 UNSCREW OLD DIAPHRAGM

ADAPTER RING

CROSSHEAD

3

9 WITH DIAL SET IN SAME COUNTER CLOCKWISE (FULL OUT) POSITION, INSTALL NEW DIAPHRAGM, THREADING INTO CROSSHEAD ALL THE WAY. DO NOT OVER-TIGHTEN!

4

11 REINSTALL SCREWS, TAKING EACH ONE DOWN BY HAND UNTIL IT STOPS. TIGHTEN SCREWS TO 40 IN. LBS. * IN THE ORDER SHOWN BELOW. TORQUE EACH SCREW IN THE PATTERN, THEN REPEAT THE TORQUE SEQUENCE ONLY ONCE!

5

NOTE: AFTER THIS PROCEDURE IS COMPLETE, YOU MUST RECALIBRATE THE INJECTOR TO YOUR SPECIFICATIONS.

10 ROTATE DIAL FULLY IN OPPOSITE DIRECTION (CLOCKWISE) BRINGING DIAPHRAGM AT REST AGAINST ADAPTER RING.

12 ROTATE DIAL COUNTER CLOCKWISE ENOUGH TO INSTALL DRIVE BEARING. INSTALL SNAP RING.

13 REMOVE DIAL KNOB. REINSTALL CAM GUIDE / COVER AND STROKE INDICATOR PLATE. REINSTALL ADJUSTMENT KNOB AND POSITION IT ON ORIGINAL % SETTING. INSTALL LOCK SCREW, LOCK DIAL IN PLACE.

WARNING!
FAILURE TO FOLLOW THIS PROCEDURE WILL RESULT IN POOR PUMP PERFORMANCE WITH DIAPHRAGM DEFORMATION AND PREMATURE FAILURE.

FOR TECHNICAL ASSISTANCE CALL HAMMONDS TECH. SVS. (281) 999-2900

DRAWING	LEVELS	VIEW
1461	5, 6	1

HAMMONDS TECHNICAL SERVICES, INC.

SCALE NTS	APPROVED	PART NUMBER	DRAWN BY SS
DATE 10/03/1997			REVISED -
DRAWING TITLE "L" DIAPHRAGM REPLACEMENT			
HEAVY DUTY PUMP SERIES			DRAWING NUMBER 1461-1

Hammonds Model AC800-2L-1P7 Injection Cart Manual

26	882352	2	LOCK WASHER, 5/16" SS (OPTION)
27	883863	2	SCREW, 5/16-18 x 1 1/4" SS (OPTION)
27A	882351	2	SCREW, 5/16-18 x 2 3/4" SS (OPTION)
28	102480	2	O-RING (OPTION)
29	102747A	1	DUST CAP (OPTION)
30			
31	102746	1	DUST PLUG (OPTION)

ITEM	PART NO.	QTY.	DESCRIPTION
1	102757	1	POWER FRAME, HD ALUM.
2	881045	1	SETSCREW, 1/4-20 x 1 (PART OF #3)
3	102192	1	PLUNGER, P7
4	881765	1	SEAL, LIP
5	101749	1	1/8" FILTER (OPTION)
6	102194	1	SEAL HOUSING
6A	102474	1	SEAL HOUSING, VENTED (OPTION)
7	101490	1	O-RING, AFLAS
	101226	1	O-RING, VITON (OPTION)
	101754	1	O-RING, KALREZ (OPTION)
8	102193	1	FLUID END, P7
9	882949	12	LOCK WASHER, #10 INTERNAL
10	881317	4	SCREW, #10-32 x 2"
11	104311	2	CHECK VALVE, 1PSI, AFLAS
	104310	2	CHECK VALVE, 1PSI, VITON (OPT)
12	101007	2	RETURN SPRING
13	101006	1	CROSSHEAD
14	101152	2	SLIDE BEARING
15	101005	1	STROKE ADJUSTMENT CAM
16	102758	1	PUMP FRAME COVER, HD ALUM
17	101670	1	STROKE INDICATOR
18	101037	2	SCREW, #10-32 x 1 1/2"
19	881126	4	SCREW, #10-32 x 1 1/2"
19A	881126	4	SCREW, #10-32 x 1 1/2" (OPTION)
20	101001	1	STROKE ADJUSTMENT KNOB
21	101749	1	1/8" FILTER (OPTION)
22	881301	4	SCREW, #10-32 x 1"
22A	883170	4	SCREW, #10-32 x 2 1/2" (OPT)
23	101038	4	LOCK WASHER, #10 H.C.
24	104315	1	CHECK VALVE, 5 PSI, AFLAS
	104314	1	CHECK VALVE, 5 PSI, VITON (OPT)
25	101088	1	3/8 x 1/4 FNPT TUBE ADAPT.

NEW CHECK VALVES	04/19/23	SS	X	DRAWING	LEVELS
ADDED STD DUST CAP	09/30/16	SS	X	INJECTOR	40, 90-93, 95-97, 129, 139-141
INITIAL RELEASE	02/16/07	SS	X	FROM SER#	DATE TO SER# DATE
NO. REVISION				X	X X X

TOLERANCES
ALL DIMENSIONS ARE IN INCHES UNLESS OTHERWISE SPECIFIED.

*TOL. DECIMALS:
.XXX= +/- .005
.XX= +/- .015
.X= +/- .030
FRAC. = +/- 1/16

*TOL. ANGLES:
+/- .5 DEGREES

*CONCENTRICITY:
.005 T. I. R.

*REMOVE BURRS AND BREAK EDGES .005 MIN.

THIS PRINT IS CONFIDENTIAL AND IS THE PROPERTY OF HAMMONDS TECHNICAL SERVICES

THIS PRINT SHALL NOT BE USED, COPIED OR REPRODUCED IN WHOLE OR IN PART, NOR SHALL THE CONTENTS BE REVEALED IN ANY MANNER TO ANYONE UNLESS WRITTEN PERMISSION IS OBTAINED FROM HAMMONDS TECHNICAL SERVICES.

HAMMONDS TECHNICAL SERVICES, INC.			
SCALE: NTS	APPROVED: PART NUMBER	DRAWN BY: SS	
DATE: 02/16/07		REVISED: 04/19/23	
DRAWING TITLE: HAMMONDS 1P7 PUMP			
HEAVY DUTY			DRAWING NUMBER: 5550

Hammonds Model AC800-2L-1P7 Injection Cart Manual

ITEM	PART NO.	QTY.	DESCRIPTION
1	102469-01	1	RESERVOIR
2	271093	1	NIPPLE, 3/4" x 2"
3	271131	1	TEE, 3/4"
4	101069	2	PIPE NIPPLE, 1/4" x CL.
5	101021	2	ELBOW, 1/4" FNPT
6	271353	2	PIPE NIPPLE, 1/4" x 2-1/2"
7	101561	2	TUBE ADAPT, 1/2" x 1/4" ELBOW
8	101379	2	1/2" TEFLON TUBE
9	101685	2	1/2" INSERT
10	101337	1	O-RING
11	882333	1	STRIP GAUGE
12	401952	3	DRIVE SCREW, #6
13	101230	1	ON/OFF VALVE, 1/4"
14	101068	1	TUBE ELBOW/MNPT, 3/8" x 1/4"
15	881198-05	1	VENT TUBE, 3/8"
16		1	SIGHT FLOW INDICATOR (OPT)
17		1	Y-STRAINER (OPT)
18	101070	1	PIPE NIPPLE, 1/4" x 1-1/2"

10.0.0.0.0.0		*10.0.0.0.0.0*		*10.0.0.0.0.0*	
NO.	REVISION	DATE	BY	NO.	REVISION
1		10/19/23	SS	1	
2		09/21/14	SS	2	
3		08/23/12	SS	3	

10.0.0.0.0.0		*10.0.0.0.0.0*		*10.0.0.0.0.0*	
NO.	REVISION	DATE	BY	NO.	REVISION
1		10/19/23	SS	1	
2		09/21/14	SS	2	
3		08/23/12	SS	3	

10.0.0.0.0.0		*10.0.0.0.0.0*		*10.0.0.0.0.0*	
NO.	REVISION	DATE	BY	NO.	REVISION
1		10/19/23	SS	1	
2		09/21/14	SS	2	
3		08/23/12	SS	3	

10.0.0.0.0.0		*10.0.0.0.0.0*		*10.0.0.0.0.0*	
NO.	REVISION	DATE	BY	NO.	REVISION
1		10/19/23	SS	1	
2		09/21/14	SS	2	
3		08/23/12	SS	3	

10.0.0.0.0.0		*10.0.0.0.0.0*		*10.0.0.0.0.0*	
NO.	REVISION	DATE	BY	NO.	REVISION
1		10/19/23	SS	1	
2		09/21/14	SS	2	
3		08/23/12	SS	3	

10.0.0.0.0.0		*10.0.0.0.0.0*		*10.0.0.0.0.0*	
NO.	REVISION	DATE	BY	NO.	REVISION
1		10/19/23	SS	1	
2		09/21/14	SS	2	
3		08/23/12	SS	3	

10.0.0.0.0.0		*10.0.0.0.0.0*		*10.0.0.0.0.0*	
NO.	REVISION	DATE	BY	NO.	REVISION
1		10/19/23	SS	1	
2		09/21/14	SS	2	
3		08/23/12	SS	3	

10.0.0.0.0.0		*10.0.0.0.0.0*		*10.0.0.0.0.0*	
NO.	REVISION	DATE	BY	NO.	REVISION
1		10/19/23	SS	1	
2		09/21/14	SS	2	
3		08/23/12	SS	3	

10.0.0.0.0.0		*10.0.0.0.0.0*		*10.0.0.0.0.0*	
NO.	REVISION	DATE	BY	NO.	REVISION
1		10/19/23	SS	1	
2		09/21/14	SS	2	
3		08/23/12	SS	3	

10.0.0.0.0.0		*10.0.0.0.0.0*		*10.0.0.0.0.0*	
NO.	REVISION	DATE	BY	NO.	REVISION
1		10/19/23	SS	1	
2		09/21/14	SS	2	
3		08/23/12	SS	3	

10.0.0.0.0.0		*10.0.0.0.0.0*		*10.0.0.0.0.0*	
NO.	REVISION	DATE	BY	NO.	REVISION
1		10/19/23	SS	1	
2		09/21/14	SS	2	
3		08/23/12	SS	3	

10.0.0.0.0.0		*10.0.0.0.0.0*		*10.0.0.0.0.0*	
NO.	REVISION	DATE	BY	NO.	REVISION
1		10/19/23	SS	1	
2		09/21/14	SS	2	
3		08/23/12	SS	3	

10.0.0.0.0.0		*10.0.0.0.0.0*		*10.0.0.0.0.0*	
NO.	REVISION	DATE	BY	NO.	REVISION
1		10/19/23	SS	1	
2		09/21/14	SS	2	
3		08/23/12	SS	3	

10.0.0.0.0.0		*10.0.0.0.0.0*		*10.0.0.0.0.0*	
NO.	REVISION	DATE	BY	NO.	REVISION
1		10/19/23	SS	1	
2		09/21/14	SS	2	
3		08/23/12	SS	3	

10.0.0.0.0.0		*10.0.0.0.0.0*		*10.0.0.0.0.0*	
NO.	REVISION	DATE	BY	NO.	REVISION
1		10/19/23	SS	1	
2		09/21/14	SS	2	
3		08/23/12	SS	3	

10.0.0.0.0.0		*10.0.0.0.0.0*		*10.0.0.0.0.0*	
NO.	REVISION	DATE	BY	NO.	REVISION
1		10/19/23	SS	1	
2		09/21/14	SS	2	
3		08/23/12	SS	3	

10.0.0.0.0.0		*10.0.0.0.0.0*		*10.0.0.0.0.0*	
NO.	REVISION	DATE	BY	NO.	REVISION
1		10/19/23	SS	1	
2		09/21/14	SS	2	
3		08/23/12	SS	3	

10.0.0.0.0.0		*10.0.0.0.0.0*		*10.0.0.0.0.0*	
NO.	REVISION	DATE	BY	NO.	REVISION
1		10/19/23	SS	1	
2		09/21/14	SS	2	
3		08/23/12	SS	3	

10.0.0.0.0.0		*10.0.0.0.0.0*		*10.0.0.0.0.0*	
NO.	REVISION	DATE	BY	NO.	REVISION
1		10/19/23	SS	1	
2		09/21/14	SS	2	
3		08/23/12	SS	3	

10.0.0.0.0.0		*10.0.0.0.0.0*		*10.0.0.0.0.0*	
NO.	REVISION	DATE	BY	NO.	REVISION
1		10/19/23	SS	1	
2		09/21/14	SS	2	
3		08/23/12	SS	3	

10.0.0.0.0.0		*10.0.0.0.0.0*		*10.0.0.0.0.0*	
NO.	REVISION	DATE	BY	NO.	REVISION
1		10/19/23	SS	1	
2		09/21/14	SS	2	
3		08/23/12	SS	3	

10.0.0.0.0.0		*10.0.0.0.0.0*		*10.0.0.0.0.0*	
NO.	REVISION	DATE	BY	NO.	REVISION
1		10/19/23	SS	1	
2		09/21/14	SS	2	
3		08/23/12	SS	3	

10.0.0.0.0.0		*10.0.0.0.0.0*		*10.0.0.0.0.0*	
NO.	REVISION	DATE	BY	NO.	REVISION
1		10/19/23	SS	1	
2		09/21/14	SS	2	
3		08/23/12	SS	3	

10.0.0.0.0.0		*10.0.0.0.0.0*		*10.0.0.0.0.0*	
NO.	REVISION	DATE	BY	NO.	REVISION
1		10/19/23	SS	1	
2		09/21/14	SS	2	
3		08/23/12	SS	3	

10.0.0.0.0.0		*10.0.0.0.0.0*		*10.0.0.0.0.0*	
NO.	REVISION	DATE	BY	NO.	REVISION
1		10/19/23	SS	1	
2		09/21/14	SS	2	
3		08/23/12	SS	3	

10.0.0.0.0.0		*10.0.0.0.0.0*		*10.0.0.0.0.0*	
NO.	REVISION	DATE	BY	NO.	REVISION
1		10/19/23	SS	1	
2		09/21/14	SS	2	
3		08/23/12	SS	3	

10.0.0.0.0.0		*10.0.0.0.0.0*		*10.0.0.0.0.0*	
NO.	REVISION	DATE	BY	NO.	REVISION
1		10/19/23	SS	1	
2		09/21/14	SS	2	
3		08/23/12	SS	3	

10.0.0.0.0.0		*10.0.0.0.0.0*		*10.0.0.0.0.0*	
NO.	REVISION	DATE	BY	NO.	REVISION
1		10/19/23	SS	1	
2		09/21/14	SS	2	
3		08/23/12	SS	3	

10.0.0.0.0.0		*10.0.0.0.0.0*		*10.0.0.0.0.0*	
NO.	REVISION	DATE	BY	NO.	REVISION
1		10/19/23	SS	1	
2		09/21/14	SS	2	
3		08/23/12	SS	3	

10.0.0.0.0.0		*10.0.0.0.0.0*		*10.0.0.0.0.0*	
NO.	REVISION	DATE	BY	NO.	REVISION
1		10/19/23	SS	1	
2		09/21/14	SS	2	
3		08/23/12	SS	3	

10.0.0.0.0.0		*10.0.0.0.0.0*		*10.0.0.0.0.0*	
NO.	REVISION	DATE	BY	NO.	REVISION
1		10/19/23	SS	1	
2		09/21/14	SS	2	
3		08/23/12	SS	3	

10.0.0.0.0.0		*10.0.0.0.0.0*		*10.0.0.0.0.0*	
NO.	REVISION	DATE	BY	NO.	REVISION
1		10/19/23	SS	1	
2		09/21/14	SS	2	
3		08/23/12	SS	3	

10.0.0.0.0.0		*10.0.0.0.0.0*		*10.0.0.0.0.0*	
NO.	REVISION	DATE	BY	NO.	REVISION
1		10/19/23	SS	1	
2		09/21/14	SS	2	
3		08/23/12	SS	3	

10.0.0.0.0.0		*10.0.0.0.0.0*		*10.0.0.0.0.0*	
NO.	REVISION	DATE	BY	NO.	REVISION
1		10/19/23	SS	1	
2		09/21/14	SS	2	
3		08/23/12	SS	3	

10.0.0.0.0.0		*10.0.0.0.0.0*		*10.0.0.0.0.0*	
NO.	REVISION	DATE	BY	NO.	REVISION
1		10/19/23	SS	1	
2		09/21/14	SS	2	
3		08/23/12	SS	3	

Hammonds Model AC800-2L-1P7 Injection Cart Manual

HAMMONDS SUCTION CALIBRATION GAUGE

CALIBRATION INSTRUCTIONS

- 1) IN ORDER TO CALIBRATE, THE PUMP MUST BE PRIMED AND PURGED OF ALL AIR. THE 3-WAY VALVE MUST BE SET TO INJECT.
- 2) WITH SUPPLY VALVE OPEN, SLOWLY OPEN VENT VALVE. THIS WILL FILL CALIBRATION GAUGE. DO NOT OVERFILL. ONCE FULL, CLOSE VENT VALVE.
- 3) MAKE NOTE OF ADDITIVE LEVEL IN CALIBRATION GAUGE AND MAIN PRODUCT METER READING. BEGIN CALIBRATION BY FIRST CLOSING THE SUPPLY VALVE AND THEN OPENING THE VENT VALVE. START THE PRODUCT FLOW (SET FOR A SHORT TRIAL RUN).
- 4) AT THE END OF THE RUN, RECORD THE AMOUNT OF ADDITIVE THAT WAS DRAWN FROM THE CALIBRATION GAUGE. RECORD THE AMOUNT OF FUEL PUMPED. CLOSE THE VENT VALVE. OPEN THE SUPPLY VALVE.
- 5) DIVIDE THE AMOUNT OF ADDITIVE USED BY THE VOLUME OF FUEL THAT WAS PUMPED GIVING YOU PPM.
- 6) INCREASE OR DECREASE PERCENTAGE OF STROKE ON DIAPHRAGM PUMP TO OBTAIN DESIRED INJECTION RATIO.

EXAMPLE: (METRIC)
ADDITIVE INJECTED = 500 ML
FUEL DELIVERED = 1785 LITERS

$$\frac{500}{1785} = .280$$

$$\frac{.280}{1000} = .000280 \text{ (280 MILLIONTHS)}$$

OR 280 PPM (PARTS PER MILLION)

EXAMPLE: (US)
ADDITIVE INJECTED = 11.5 oz
FUEL DELIVERED = 350 GALLONS

$$\frac{11.5}{350} = .0328$$

$$\frac{.0328}{128 \text{ oz/gal}} = .000256 \text{ (256 MILLIONTHS)}$$

OR 256 PPM (PARTS PER MILLION)

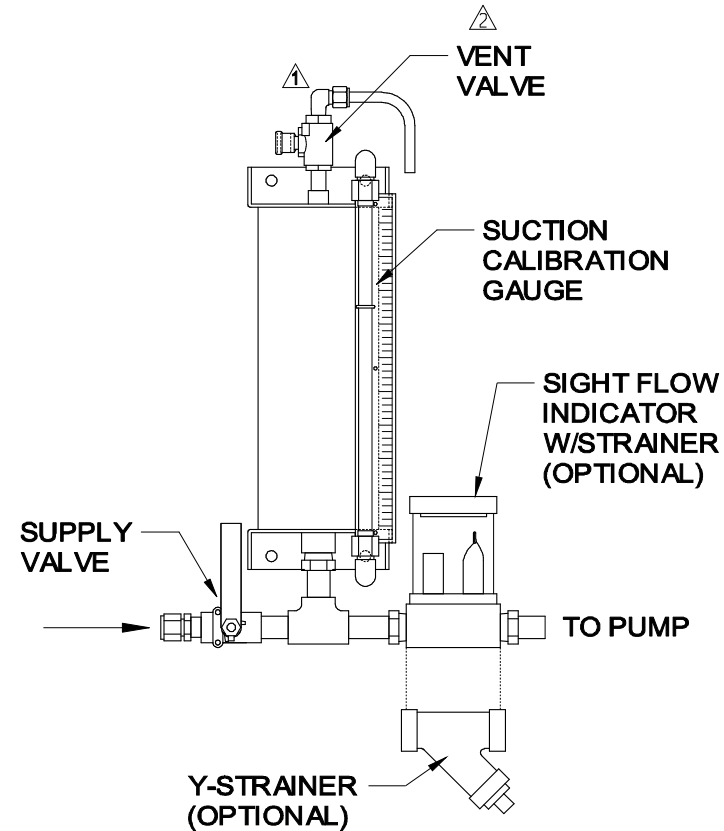

NO.	REVISION	DATE	BY	APPVD	FROM SER#	DATE	TO SER#	DATE
1	WAS ECONOMY VALVE	08/10/21	SS	JH				
2	WAS 1/4" VENT	03/21/14	SS	X				
3	INITIAL RELEASE	12/20/07	SS	X				
					X	X	X	X

TOLERANCES ALL DIMENSIONS ARE IN INCHES UNLESS OTHERWISE SPECIFIED.	
*TOL. DECIMALS: .XXX= +/- .005 .XX= +/- .015 .X= +/- .030 FRAC. = +/- 1/16	*TOL. ANGLES: +/- .5 DEGREES *CONCENTRICITY: .005 T. I. R. *REMOVE BURRS AND BREAK EDGES .005 MIN.

THIS PRINT IS
CONFIDENTIAL
AND IS THE PROPERTY OF
HAMMONDS TECHNICAL
SERVICES
THIS PRINT SHALL NOT BE USED, COPIED
OR REPRODUCED IN WHOLE OR IN PART
AND SHALL BE RETURNED TO AND/OR
DESTROYED BY THE USER UNLESS
WRITTEN PERMISSION IS OBTAINED FROM
HAMMONDS TECHNICAL SERVICES.

HAMMONDS TECHNICAL SERVICES, INC.			
SCALE	NTS	APPROVED	PART NUMBER
DATE	12/20/07		
DRAWING TITLE		DRAWING NUMBER	
SUCTION CALIBRATION GAUGE		1891A	
SCG412SS & SCG612SS			

Hammonds Model AC800-2L-1P7 Injection Cart Manual

ITEM	PART NO.	QTY.	DESCRIPTION
1	152081	1	CAP
2	152080	1	BODY
3	151010	2	GASKET, NEOPRENE
4	151009	1	GLASS
5	152025	1	FILTER ELEMENT
6	151005	1	PIPE PLUG, 1/4"
OPTIONAL:			
3	151013	2	GASKET, VITON
3	151025	2	GASKET, BUNA-N
7	102787	1	1/4" CHK VLV, 5 PSI, AFLAS

<table border="1" style="width: 100%; border-collapse: collapse;"> <tr> <td>NO.</td> <td>REVISION</td> <td>DATE</td> <td>BY</td> <td>APPVD</td> </tr> <tr> <td></td> <td></td> <td></td> <td></td> <td></td> </tr> </table>	NO.	REVISION	DATE	BY	APPVD						<table border="1" style="width: 100%; border-collapse: collapse;"> <tr> <td>DESIGNED</td> <td>SS</td> <td>JH</td> </tr> <tr> <td>DRAWING</td> <td>1349</td> <td>1</td> </tr> <tr> <td>LEVELS</td> <td>1,2</td> <td></td> </tr> <tr> <td>VIEW</td> <td></td> <td>1</td> </tr> <tr> <td>FROM SER#</td> <td>DATE</td> <td>TO SER#</td> <td>DATE</td> </tr> <tr> <td>X</td> <td>X</td> <td>X</td> <td>X</td> </tr> </table>	DESIGNED	SS	JH	DRAWING	1349	1	LEVELS	1,2		VIEW		1	FROM SER#	DATE	TO SER#	DATE	X	X	X	X	<p>*TOLERANCES* ALL DIMENSIONS ARE IN INCHES UNLESS OTHERWISE SPECIFIED.</p> <p>*TOL. DECIMALS: .XX= +/- .005 .XX= +/- .015 .X= +/- .030 FRAC. = 1/16</p> <p>*TOL. ANGLES: 1/2 = 5 DEGREES</p> <p>*CONCENTRICITY: .005 T.I.R.</p> <p>*REMOVE BURRS AND BREAK EDGES .005 MIN.</p>	<p>THIS PRINT IS CONFIDENTIAL AND IS THE PROPERTY OF HAMMONDS TECHNICAL SERVICES.</p> <p>THIS PRINT SHALL NOT BE USED, COPIED OR REPRODUCED IN WHOLE OR IN PART. NO. SHALL. THE CONTENTS BE REVEALED IN ANY MANNER TO ANYONE WITHOUT WRITTEN PERMISSION IS OBTAINED FROM HAMMONDS TECHNICAL SERVICES.</p>	<p style="text-align: center;">HAMMONDS TECHNICAL SERVICES, INC.</p> <table border="1" style="width: 100%; border-collapse: collapse;"> <tr> <td>SCALE</td> <td>NYS</td> <td>APPROVED / PART NUMBER</td> <td>DRAWN BY</td> </tr> <tr> <td>DATE</td> <td>10/21/91</td> <td>152020</td> <td>SS</td> </tr> <tr> <td>DRAWING TITLE</td> <td colspan="3">HI-VOL SIGHT FLOW INDICATOR</td> </tr> <tr> <td></td> <td></td> <td></td> <td>REVISED 01/21/23</td> </tr> <tr> <td></td> <td></td> <td></td> <td>DRAWING NUMBER 1349</td> </tr> </table>	SCALE	NYS	APPROVED / PART NUMBER	DRAWN BY	DATE	10/21/91	152020	SS	DRAWING TITLE	HI-VOL SIGHT FLOW INDICATOR						REVISED 01/21/23				DRAWING NUMBER 1349
NO.	REVISION	DATE	BY	APPVD																																																		
DESIGNED	SS	JH																																																				
DRAWING	1349	1																																																				
LEVELS	1,2																																																					
VIEW		1																																																				
FROM SER#	DATE	TO SER#	DATE																																																			
X	X	X	X																																																			
SCALE	NYS	APPROVED / PART NUMBER	DRAWN BY																																																			
DATE	10/21/91	152020	SS																																																			
DRAWING TITLE	HI-VOL SIGHT FLOW INDICATOR																																																					
			REVISED 01/21/23																																																			
			DRAWING NUMBER 1349																																																			

Hammonds Model AC800-2L-1P7 Injection Cart Manual

PARTS INCLUDED IN KITS ARE IDENTIFIED WITH → NOTE: OPTIONAL O-RING ELASTOMERS ARE AVAILABLE.

INSTALL CAP HAND-TIGHT... DO NOT OVER-TIGHTEN!

NOTE: ADAPTER FITTINGS VARY PER APPLICATION... SEE YOUR ASSEMBLY ILLUSTRATION

IMPORTANT! NOTE DIRECTION OF FLOW

VALVE DETAIL SCALE: 2X

ITEM	PART NO.	QTY.	DESCRIPTION
△ 1	152075	1	BODY, STD.SIGHT FLOW
△ 2	152002	1	FILTER ELEMENT
→ 3	151018	1	GAUGE GLASS
→ 4	151002	2	GASKET, BUNA (OPT)
→	151007	2	GASKET, VITON (OPT)
→	151027	2	GASKET, NEOPR (OPT)
→	151026	2	GASKET, KALREZ (OPT)
△ 151020	2	GASKET, AFLAS (OPT)	
△ 151036	2	GASKET, TEF ENCAPSULATED	
△ 5	151005	1	PLUG
△ 6	152069	1	CAP ASSEMBLY
△ 7	101070	1	NIPPLE, 1/4" x 1-1/2"
△ 8	101059-04	1	VENT TUBE, 1/4"
→	881139-05	1	VENT TUBE, 3/8"...(OPT)
△△ 9	101230	1	ON/OFF VALVE, 1/4"
△ 10	101095	1	TUBE ADAPTER, 1/4"
→	101068	1	TUBE ADAPTER, 3/8"...(OPT)
△ 11	152070	1	GUARD, GAUGE GLASS
△△ 12	104315	1	1/4" CH VLV, 5 PSI, AFLAS (OPT)
→	104314	1	1/4" CH VLV, 5 PSI, VITON (OPT)
→	104319	1	1/4" CH VLV, 5 PSI, KALREZ (OPT)
13	881422	2	5/16-18 x 1" HX HD BOLT, SS
14	881417	2	5/16" LOCK WASHER, SS
15	104042	2	5/16" FLAT WASHER, SS

△	OPTIONAL VENTS	06/13/23	SS
△	NEW CHECK VALVES	06/09/23	SS
△	REMY'D #102735 VLV	07/13/21	SS
△	ADD TEF ENCAPSUL	07/13/21	SS
△	ADDED AFLAS OPT	09/04/20	SS
△	ADDED KIT INFO	04/30/18	SS
△	ADDED FLUSH VALVE	02/15/17	SS
△	ADDED KALREZ OPT	01/18/17	SS
△	ADDED NEOPR. OPT	09/27/11	SS
△	ADDED OPT VALVE	03/04/10	SS
△	WAS #152035	05/13/99	SS
△	WAS #152018	05/13/99	SS
△	WAS 1/8" NIPPLE	01/23/97	SS
NO.	REVISION	DATE	BY

DRAWING	LEVELS	VIEW	
2489	5,6	1	
FROM SER#	DATE	TO SER#	DATE
X	X	X	X

TOLERANCES ALL DIMENSIONS ARE IN INCHES UNLESS OTHERWISE SPECIFIED.		THIS PRINT IS CONFIDENTIAL AND IS THE PROPERTY OF HAMMONDS TECHNICAL SERVICES													
*TOL. DECIMALS: .XXX= +/- .005 .XX= +/- .015 .X= +/- .030	*TOL. ANGLES: +/- .5 DEGREES	THIS PRINT SHALL NOT BE USED, COPIED OR REPRODUCED IN WHOLE OR IN PART NOR SHALL THE CONTENTS BE REVEALED IN ANY MANNER TO WHOMEVER WRITTEN PERMISSION IS OBTAINED FROM HAMMONDS TECHNICAL SERVICES.													
*REMOVE BURRS AND BREAK EDGES .005 MIN.		<table border="1" style="width: 100%; border-collapse: collapse;"> <tr> <td colspan="2" style="text-align: center;">HAMMONDS TECHNICAL SERVICES, INC.</td> </tr> <tr> <td>SCALE: NTS</td> <td>APPROVED BY: SCG206</td> </tr> <tr> <td>DATE: 07/20/93</td> <td>DRAWN BY: SS</td> </tr> <tr> <td colspan="2" style="text-align: center;">DRAWING TITLE: SUCTION CALIBRATION GAUGE</td> </tr> <tr> <td colspan="2" style="text-align: center;">MAT'L:</td> </tr> <tr> <td colspan="2" style="text-align: right;">DRAWING NUMBER: 3067</td> </tr> </table>		HAMMONDS TECHNICAL SERVICES, INC.		SCALE: NTS	APPROVED BY: SCG206	DATE: 07/20/93	DRAWN BY: SS	DRAWING TITLE: SUCTION CALIBRATION GAUGE		MAT'L:		DRAWING NUMBER: 3067	
HAMMONDS TECHNICAL SERVICES, INC.															
SCALE: NTS	APPROVED BY: SCG206														
DATE: 07/20/93	DRAWN BY: SS														
DRAWING TITLE: SUCTION CALIBRATION GAUGE															
MAT'L:															
DRAWING NUMBER: 3067															

Hammonds Model AC800-2L-1P7 Injection Cart Manual

HAMMONDS SUCTION CALIBRATION GAUGE

CALIBRATION INSTRUCTIONS

- 1) IN ORDER TO CALIBRATE, THE PUMP MUST BE PRIMED AND PURGED OF ALL AIR. THE 3-WAY VALVE MUST BE SET TO INJECT.
- 2) WITH SUPPLY VALVE OPEN, SLOWLY OPEN VENT VALVE. THIS WILL FILL CALIBRATION GAUGE. FILL TO ZERO MARK. DO NOT OVERFILL. ONCE FULL, CLOSE VENT VALVE.
- 3) MAKE NOTE OF ADDITIVE LEVEL IN CALIBRATION GAUGE AND MAIN PRODUCT METER READING. BEGIN CALIBRATION BY FIRST CLOSING THE SUPPLY VALVE AND THEN OPENING THE VENT VALVE. START THE PRODUCT FLOW (SET FOR A SHORT TRIAL RUN).
- 4) AT THE END OF THE RUN, RECORD THE AMOUNT OF ADDITIVE THAT WAS DRAWN FROM THE CALIBRATION GAUGE. RECORD THE AMOUNT OF FUEL PUMPED. CLOSE THE VENT VALVE. OPEN THE SUPPLY VALVE.
- 5) DIVIDE THE AMOUNT OF ADDITIVE USED BY THE VOLUME OF FUEL THAT WAS PUMPED GIVING YOU PPM.
- 6) INCREASE OR DECREASE PERCENTAGE OF STROKE ON DIAPHRAGM PUMP TO OBTAIN DESIRED INJECTION RATIO.

EXAMPLE: (METRIC)
 ADDITIVE INJECTED = 500 ML
 FUEL DELIVERED = 1785 LITERS

$$\frac{500}{1785} = .280$$

$$\frac{.280}{1000} = .000280 \text{ (280 MILLIONTHS)}$$

OR 280 PPM (PARTS PER MILLION)

EXAMPLE: (US)
 ADDITIVE INJECTED = 11.5 oz
 FUEL DELIVERED = 350 GALLONS

$$\frac{11.5}{350} = .0328$$

$$\frac{.0328}{128 \text{ oz/gal}} = .000256 \text{ (256 MILLIONTHS)}$$

OR 256 PPM (PARTS PER MILLION)

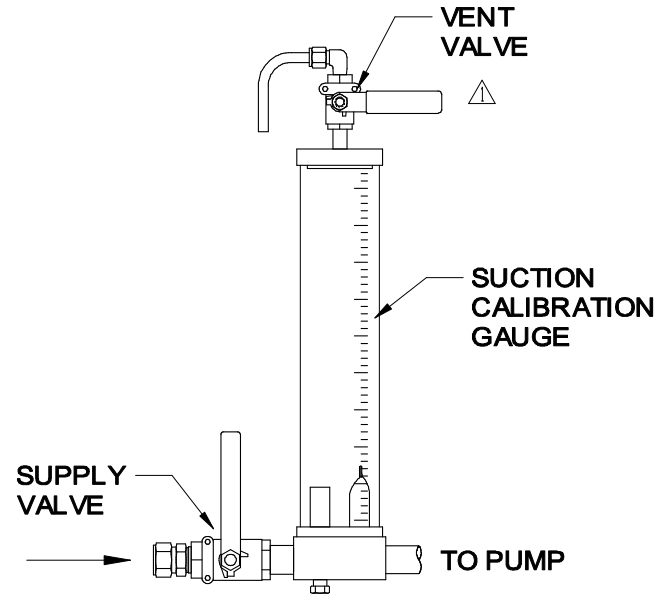

TOLERANCES ALL DIMENSIONS ARE IN INCHES UNLESS OTHERWISE SPECIFIED.		THIS PRINT IS CONFIDENTIAL AND IS THE PROPERTY OF HAMMONDS TECHNICAL SERVICES		HAMMONDS TECHNICAL SERVICES, INC.	
*TOL. DECIMALS: .XXX± +/- .005 .XX± +/- .015 .X± +/- .030		*TOL. ANGLES: +/- .5 DEGREES		SCALE: NTS DATE: 04/07/93	APPROVED BY: DRAWN BY: SS REVISED: 07/13/21
*CONCENTRICITY: .005 T.I.R.		THIS PRINT SHALL NOT BE USED, COPIED OR REPRODUCED IN WHOLE OR IN PART AND SHALL BE RETURNED TO THE ORIGINAL OWNER IN ANY MANNER TO WHOMEVER WRITTEN PERMISSION IS OBTAINED FROM HAMMONDS TECHNICAL SERVICES.		DRAWING TITLE: SUCTION CALIBRATION GAUGE	
SURF FINISH: 125/ *REMOVE BURRS AND BREAK EDGES .005 MIN.				DRAWING NUMBER: 1891	
WAS ECONOMY VALVE 07/13/21 SS	DRAWING LEVELS VIEW 1891 1,2 1	FROM SER# DATE TO SER# DATE X X X X			
INITIAL RELEASE 04/07/93 SS					
NO. REVISION DATE BY					

Hammonds Model AC800-2L-1P7 Injection Cart Manual

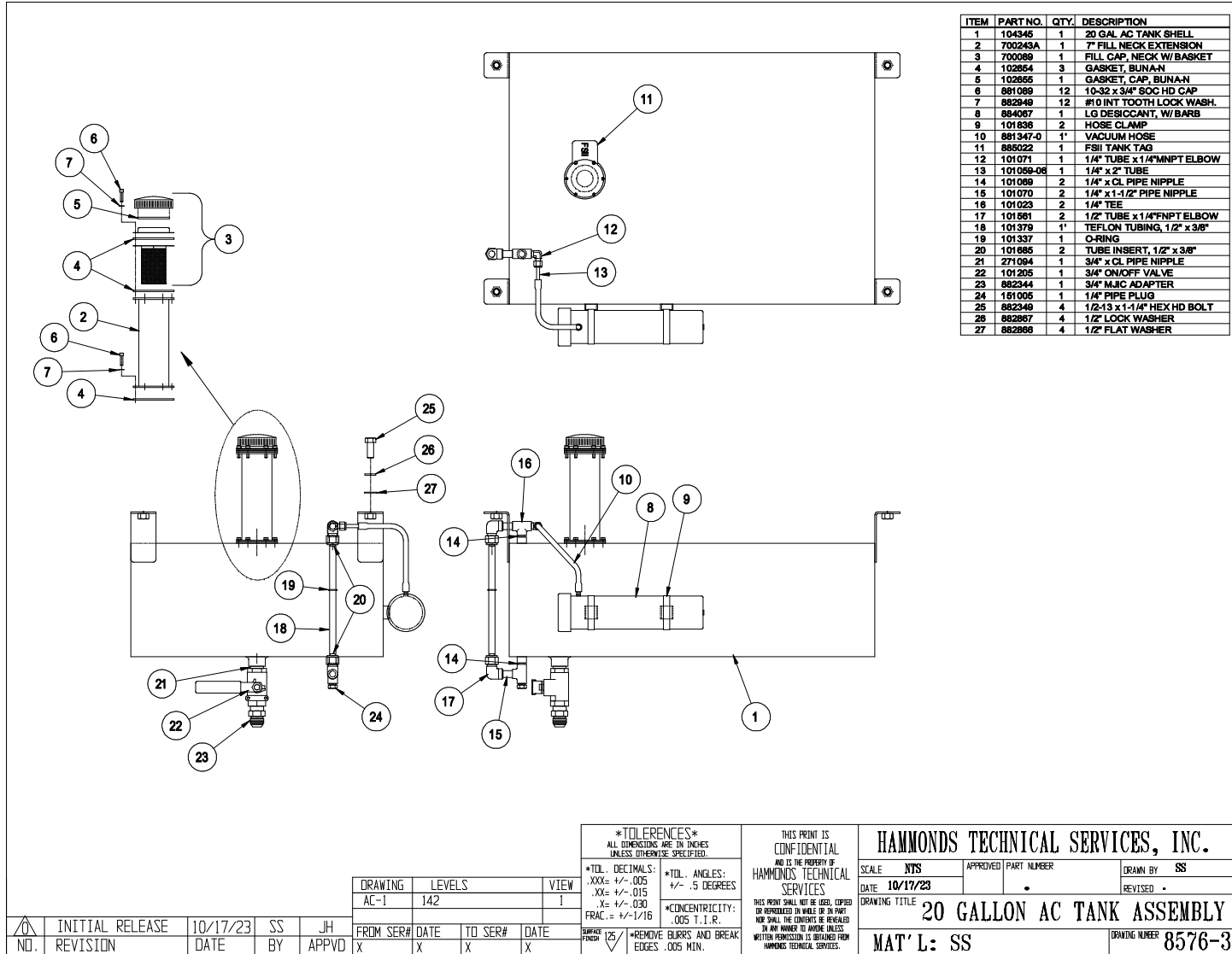

TOLERANCES ALL DIMENSIONS ARE IN INCHES UNLESS OTHERWISE SPECIFIED.		THIS PRINT IS CONFIDENTIAL AND IS THE PROPERTY OF HAMMONDS TECHNICAL SERVICES		HAMMONDS TECHNICAL SERVICES, INC.	
*TOL. DECIMALS:	*TOL. ANGLES:	SCALE	APPROVED	PART NUMBER	DRAWN BY
.XX = +/- .005	+/- .5 DEGREES	NTS			SS
.XX = +/- .015		DATE	10/17/23		REVISED
.X = +/- .030	*CONCENTRICITY:	DRAWING TITLE 20 GALLON AC TANK ASSEMBLY			
FRAC. = +/- 1/16	.005 T.I.R.	MAT'L: SS			
*REMOVE BURRS AND BREAK EDGES .005 MIN.		THIS PRINT SHALL NOT BE USED, COPIED OR REPRODUCED IN WHOLE OR IN PART WITHOUT THE CONSENT OF THE ISSUER. IN ANY MANNER TO AVOID UNLESS WITH THE PERMISSION IS OBTAINED FROM HAMMONDS TECHNICAL SERVICES.		DRAWING NUMBER 8576-3	

NO.	REVISION	DATE	BY	APPVD	FROM SER#	DATE	TO SER#	DATE
	INITIAL RELEASE	10/17/23	SS	JH				

DRAWING	LEVELS	VIEW
AC-1	142	1

Hammonds Model AC800-2L-1P7 Injection Cart Manual

ITEM	PART NO.	QTY.	DESCRIPTION
1	104347	1	1 GAL AC TANK SHELL
2	700089	1	FILL CAP, NECK W/ BASKET
3	102460	2	GASKET, VITON
4	102482	1	GASKET, VITON
5	881089	6	10-32 x 3/4" SOC HD CAP
6	882949	6	#10 INT TOOTH LOCK WASH.
7	101071	1	1/4" TUBE x 1/4"MNPT ELBOW
8		1	1/4" VENT TUBE (101059)
9	101069	2	1/4" x CL PIPE NIPPLE
10	101070	3	1/4" x 1-1/2" PIPE NIPPLE
11	101023	2	1/4" TEE
12	101561	2	1/2" TUBE x 1/4"FNPT ELBOW
13	101379	1'	TEFLON TUBING, 1/2" x 3/8"
14	101337	1	O-RING
15	101685	2	TUBE INSERT, 1/2" x 3/8"
16	151005	1	1/4" PIPE PLUG
17	101230	1	1/4" ON/OFF VALVE
18	882339	1	3/8" MJIC x 1/4"MNPT ADAPT
19	882362	1	CI TANK TAG
20	883233	3	3/8-16 x 1-1/4" HEX HD BOLT
21	882840	6	3/8" FLAT WASHER
22	881711	3	3/8" LOCK WASHER
23	881710	3	3/8-16 HEX NUT

NO.	REVISION	DATE	BY	APPVO	
△	INITIAL RELEASE	10/17/23	SS	JH	

TOLERANCES ALL DIMENSIONS ARE IN INCHES UNLESS OTHERWISE SPECIFIED. *TOL. DECIMALS: .XXX= +/- .005 .XX= +/- .015 .X= +/- .030 FRAC. = +/- 1/16 *TOL. ANGLES: +/- .5 DEGREES *CONCENTRICITY: .005 T. I. R. SURFACE FINISH: $\sqrt{25}$ *REMOVE BURRS AND BREAK EDGES .005 MIN.	THIS PRINT IS CONFIDENTIAL AND IS THE PROPERTY OF HAMMONDS TECHNICAL SERVICES THIS PRINT SHALL NOT BE USED, COPIED OR REPRODUCED IN WHOLE OR IN PART NOR SHALL THE CONTENTS BE REVEALED IN ANY MANNER TO ANYONE UNLESS WRITTEN PERMISSION IS OBTAINED FROM HAMMONDS TECHNICAL SERVICES.	HAMMONDS TECHNICAL SERVICES, INC. SCALE: N7S DATE: 10/17/23 DRAWING TITLE: 1 GALLON AC TANK ASSEMBLY MAT'L: SS
---	--	--

DRAWING: AC-1 LEVELS: 143 VIEW: I	FROM SER# DATE TO SER# DATE	APPROVED: [Signature] PART NUMBER: [Blank] DRAWN BY: SS REVISED: [Blank]	DRAWING NUMBER: 8578-3
---	--------------------------------------	---	----------------------------------

Hammonds Model AC800-2L-1P7 Injection Cart Manual

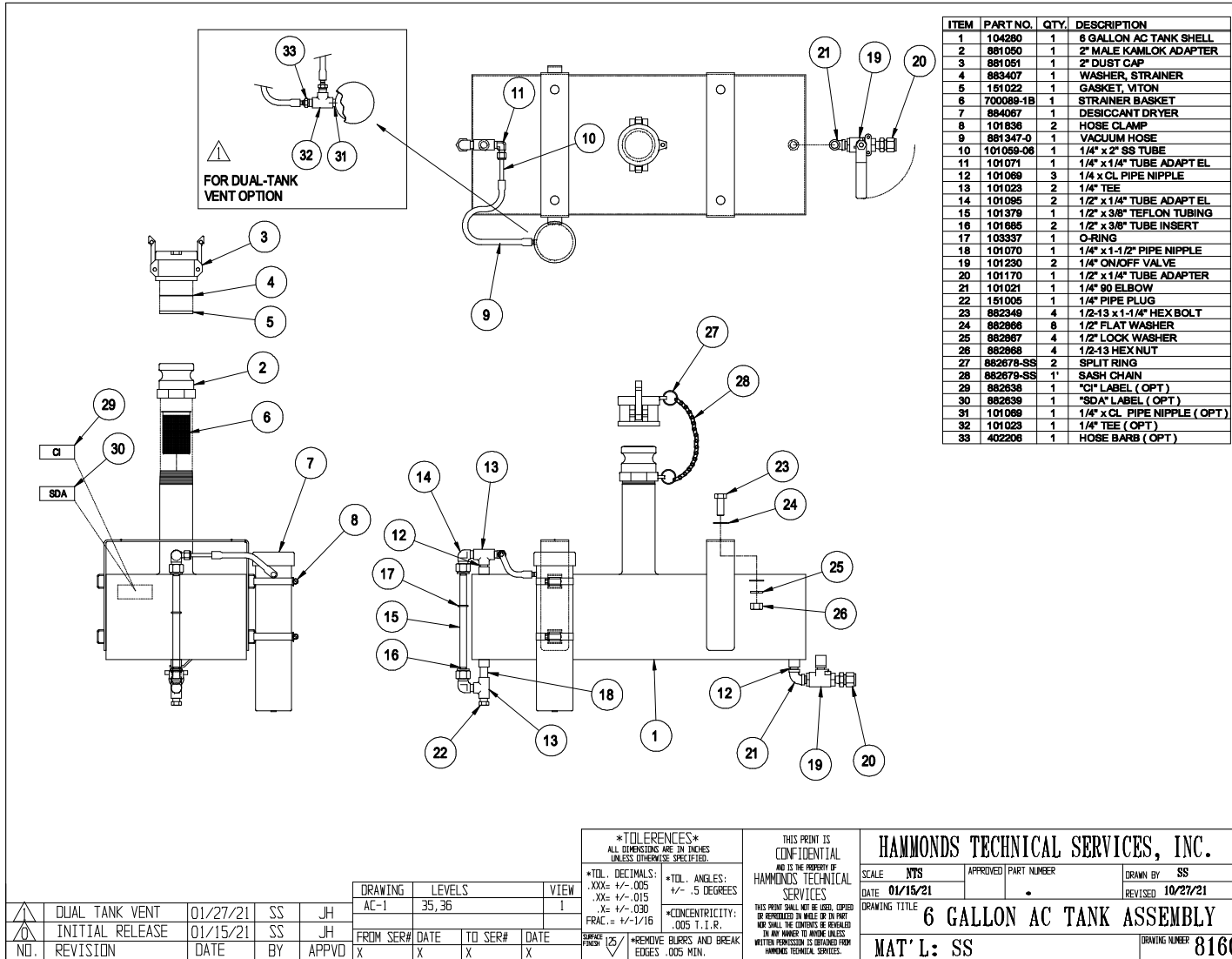

<p>*TOLERANCES* ALL DIMENSIONS ARE IN INCHES UNLESS OTHERWISE SPECIFIED.</p>		<p>THIS PRINT IS CONFIDENTIAL AND IS THE PROPERTY OF HAMMONDS TECHNICAL SERVICES</p>		<p>HAMMONDS TECHNICAL SERVICES, INC.</p>	
<p>*TOL. DECIMALS: .XXx +/- .005 .XXx +/- .015 .Xx +/- .030 FRAC. = +/- 1/16</p>		<p>*TOL. ANGLES: +/- .5 DEGREES</p>		<p>SCALE: NTS APPROVED PART NUMBER DATE: 01/15/21 .</p>	
<p>*CONCENTRICITY: .005 T.I.R.</p>		<p>*REMOVE BURRS AND BREAK EDGES .005 MIN.</p>		<p>DRAWN BY: SS REVISED: 10/27/21</p>	
<p>NO. REVISION</p>		<p>DUAL TANK VENT INITIAL RELEASE REVISION</p>		<p>DATE: 01/27/21 01/15/21</p>	
<p>BY: JH APPVD: X</p>		<p>LEVELS: AC-1 35,36</p>		<p>DRAWING TITLE: 6 GALLON AC TANK ASSEMBLY</p>	
<p>FROM SER# DATE TO SER# DATE</p>		<p>VIEW: 1</p>		<p>DRAWING NUMBER: 8160</p>	
<p>DATE: X DATE: X DATE: X</p>		<p>SURFACE FINISH: 25</p>		<p>MAT'L: SS</p>	

Hammonds Model AC800-2L-1P7 Injection Cart Manual

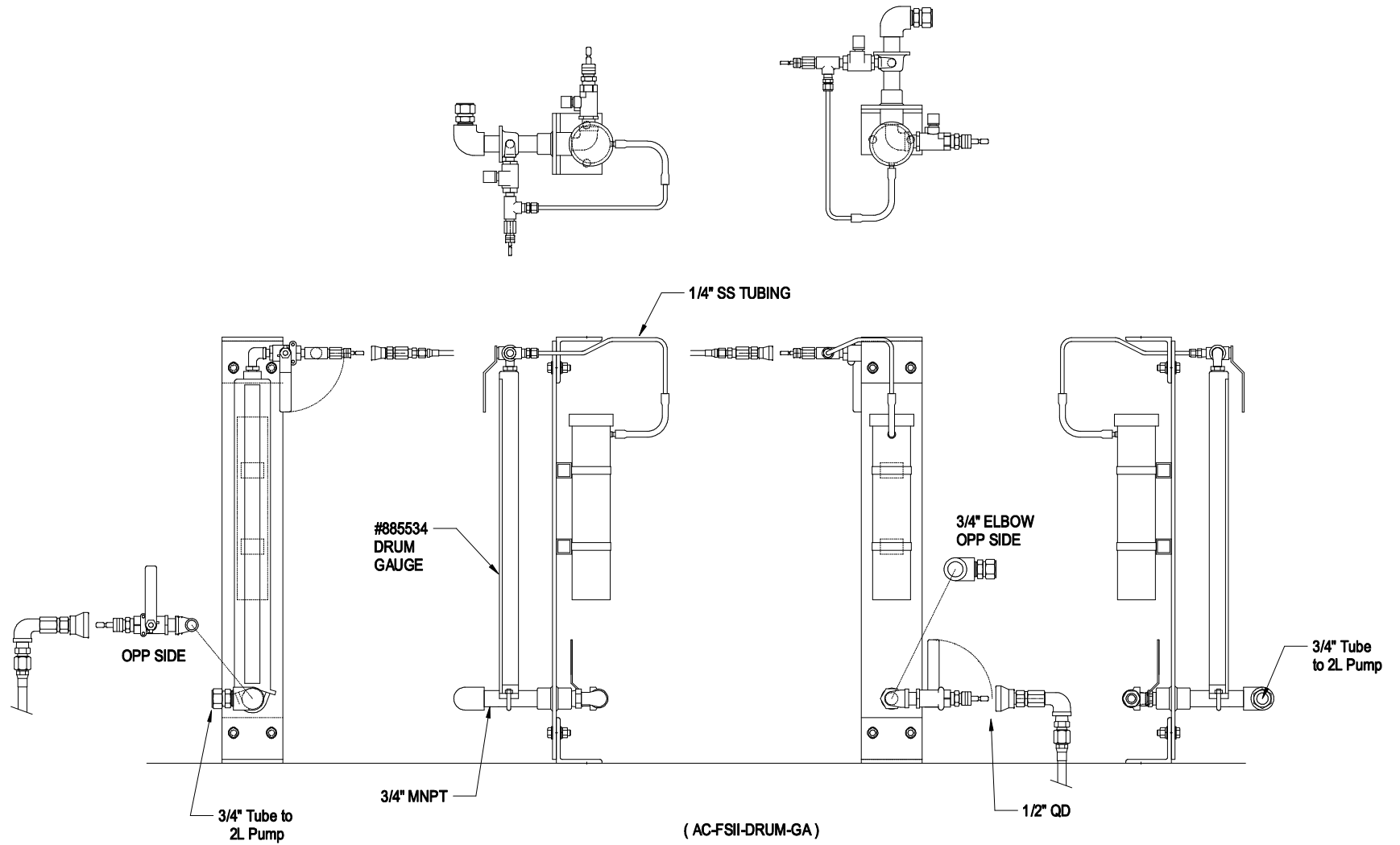

(AC-FSII-DRUM-GA)

DWG# 8130 10/21/20
 DRUM GAUGE, ACCART, FSII
 (AC-1 29)

Hammonds Model AC800-2L-1P7 Injection Cart Manual

INSTALLING A NEW DRUM OF ADDITIVE

1. Set the brakes on the cart.
2. Remove hoses from the cart at the quick disconnects. **DO NOT TAKE ANY OF THE FITTINGS LOOSE FROM THE HOSES!**
3. While the drum is on the ground and standing upright, install the hoses in the proper bung hole size. The hose with the large 2" fitting is the vent hose. The hose with the smaller 3/4" fitting is the fluid hose. Install the hoses with the 90 deg. elbows as shown below.

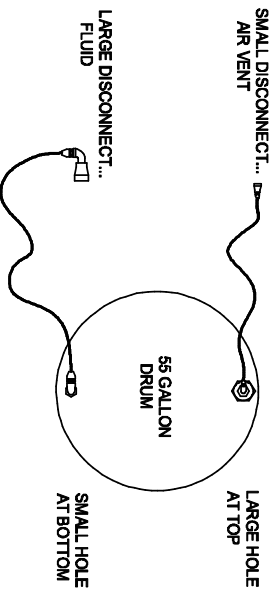

4. Tie the hoses loosely together so they won't be damaged while the drum is being handled. Don't crimp them, just make certain they don't hang loose and become mashed or crimped during drum installation.
5. Lay the drum over on its side. **GET SOME HELP. BE CAREFUL, DON'T DROP THE DRUM ON YOUR FOOT OR A HOSE.**
6. Using a forklift and some help, position the drum in the rack with the hoses on the left side as you face the rear of the cart. The hoses should be on the same side as the level gauge when installed. **BE CAREFUL NOT TO DAMAGE THE HOSES WHEN INSTALLING THE DRUM INTO THE CART. THE CLEARANCE IS CLOSE.**
7. Position the drum with the large bung hole at the top at 12:00 o'clock, and the small bung hole at the bottom at 6:00 o'clock. The elbows going into the drum should be turned toward the sight level gauge as the drawing shows.
8. Connect the quick disconnects into their position. The small one at the top on the air vent, and the large one at the bottom on the fluid side. The disconnects are self closing, so do not close or open any valves in the suction line leading to the injector.
9. Using the ratchet and nylon strap, lock down the drum securely.

The system is now ready for use.

Hammonds Model AC800-2L-1P7 Injection Cart Manual

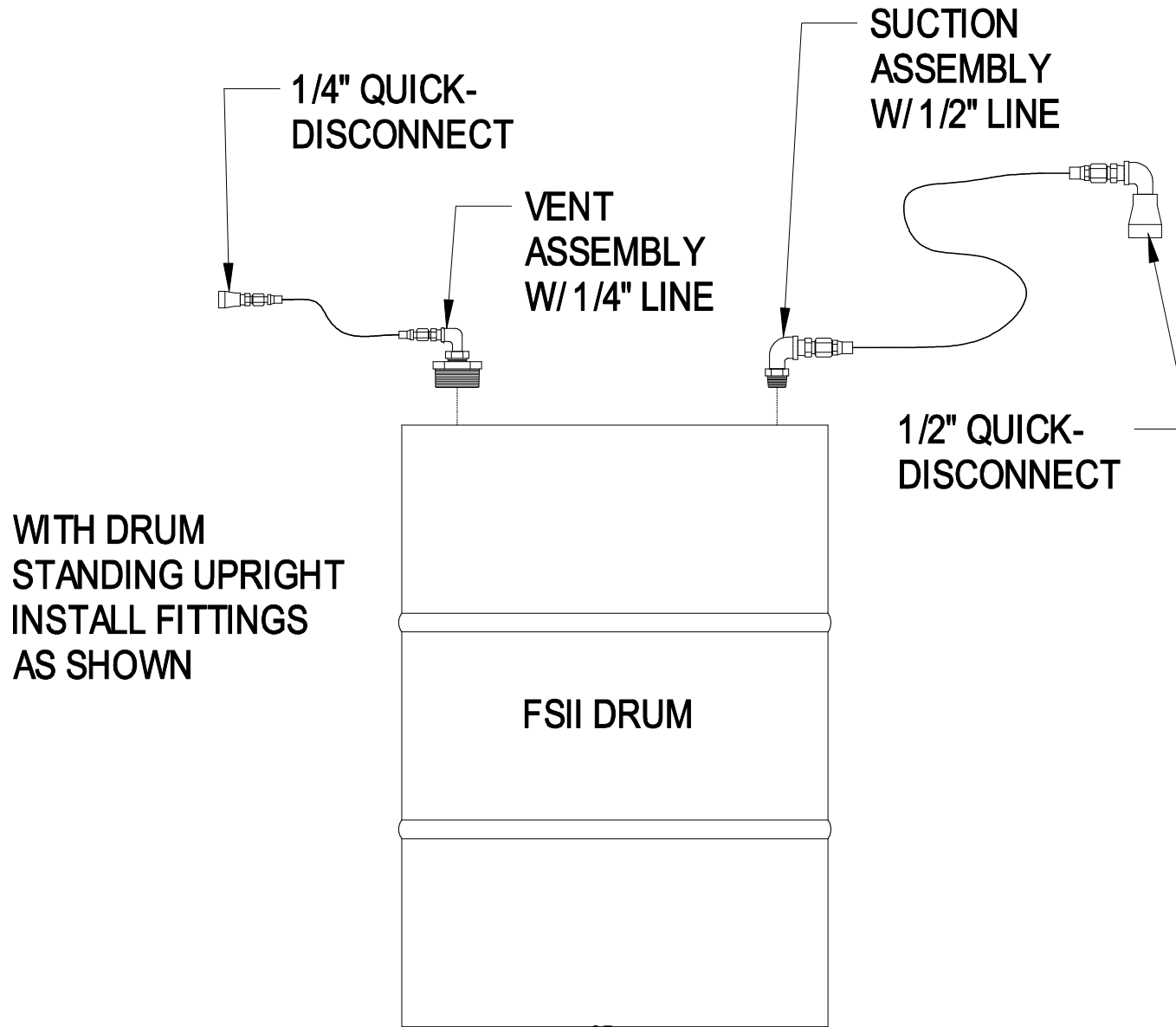

Hammonds Model AC800-2L-1P7 Injection Cart Manual

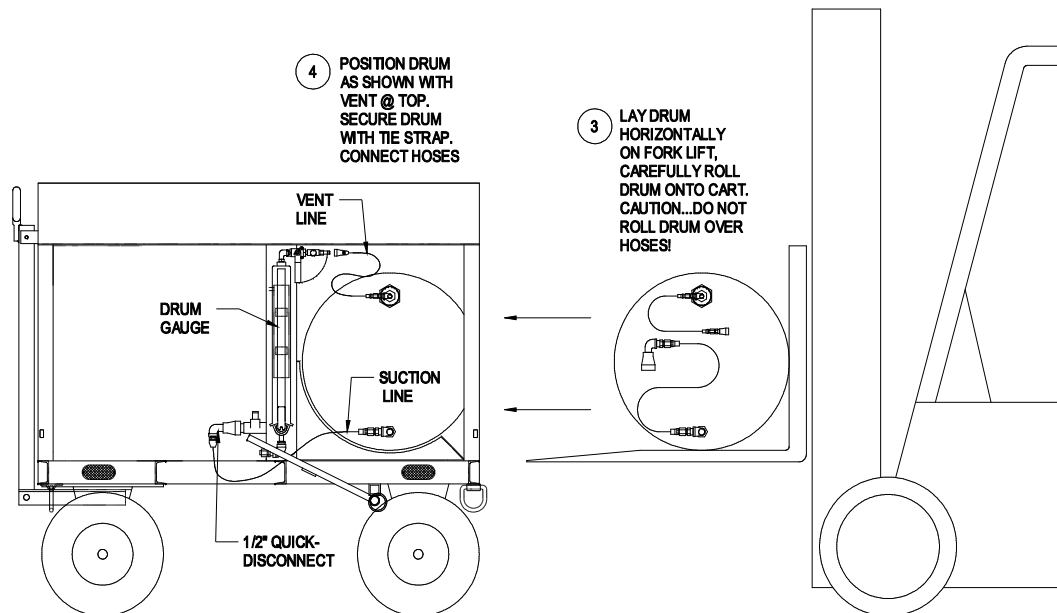
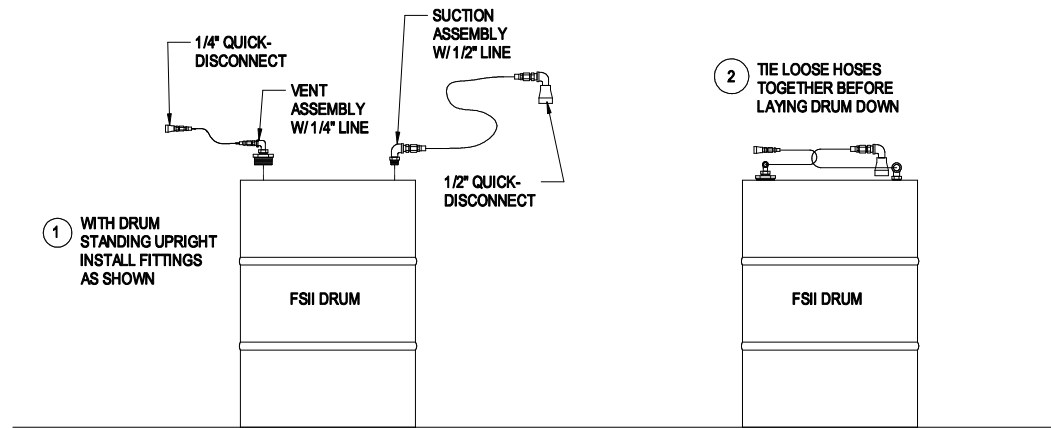

INSTALLING A NEW DRUM OF ADDITIVE