

**OPERATING INSTRUCTIONS
AND
MAINTENANCE MANUAL
FOR**

**HAMMONDS MODEL PHC1-OWN (600-1*)
(*PUMP MODELS VARY)**

PORTABLE HAND CART

Manufactured by:



HAMMONDS TECHNICAL SERVICES, INC.

6807 West Little York Rd.
Houston, Texas 77040

Phone: 281-999-2900

Fax: 281-847-1857

www.hammondscos.com

October 2018

Hammonds Model PHC1 600-1 Portable Hand Cart Manual

TABLE OF CONTENTS

Special Notice to Users	3
Installation and Preparation for Startup	3-4
Preparation for Calibration and Startup	4
Calibration and Startup	5-7
Additive Chart	8
Trouble Shooting the System	8-9
Preventive Maintenance	9-10
Preventive Maintenance Schedule	10
Desiccant Dryer Instructions	11

Attachments:

- PHC1-OWN 600-1 Hand Cart Layout
- Model 600 Driver
- 1S Injector Pump
- Diaphragm Replacement
- Plunger Pumps, P2 thru P10
- 5SF, 5 Gallon Siphon Tube Assembly
- 5SF Base Assembly

Hammonds Model PHC1 600-1 Portable Hand Cart Manual

SPECIAL NOTICE TO USERS PLEASE READ CAREFULLY BEFORE OPERATING EQUIPMENT

This additive injector system is designed to give consistent dependable performance when operated and maintained according to manufacturer's recommendations. However, being a mechanical device, it is subject to failure from improper installation, wear, human error and operating environments beyond the control of the system. Because of this fact, it is the responsibility of the operator to make certain that:

- A. The system is installed properly.
- B. The system is being operated properly.
- C. The system is actually running during product transfer.
- D. The system is checked after the transfer operation to make certain the proper amount of additive was injected during the operation.

The performing of these checks by the operator eliminates the possibility of product not having the proper additive ratio as required. Therefore, since the manufacturer cannot be present during each transfer operation, the responsibility for checking the performance of the system is that of the operator. Should there be any questions whatsoever, the operator should consult the distributor from whom the unit was purchased.

Do Not Take Chances.....Do Not Guess.....Be Absolutely Certain That The System Is Installed And Working As It Should.

The user/operator carries the final responsibility to make certain the system is operating properly.

INSTALLATION AND PREPARATION FOR STARTUP

In most cases, the Hammonds fluid powered injector is shipped complete and ready to operate. The system should include appropriate fittings to suit your specific application. Flow direction is marked on additive pumps and check valves.

FLOW CONSIDERATIONS

The Hammonds Model 600 requires a minimum of 20 and up to 200 GPM to deliver consistent ratios. This does not mean that the system cannot be used in cases where startup and shutdown fall under the 20 GPM minimum. However, these installations require calibration to compensate for the lower flow rates during

these periods of operation. Check with the factory if you have any questions in the area of performance.

MATERIALS OF CONSTRUCTION

The standard material in a Hammonds Model 600 fluid driver is anodized cast aluminum housing. Optional material is carbon steel.

CAUTION

Do Not Attempt To Use This Device Without Understanding And Following Proper Safety Precautions Regarding System Grounding, Fire Safety, And Special Handling For Potentially Dangerous Additives.

Hammonds Model PHC1 600-1 Portable Hand Cart Manual

Consult your Engineering Department for their specific instructions. Make certain all personnel involved with this system are thoroughly familiar with safe operating practices.

If your system has been purchased "bare," consult your equipment distributor for help in selecting hoses, fittings and other related accessories. Selection of materials

compatibility, location of unit within the system, effect of the unit on the system and injection point of the additive are also factors that should be discussed by factory authorized personnel.

If no factory-authorized distributor is available, consult the factory directly for assistance.

PREPARATION FOR CALIBRATION AND STARTUP

Before Attempting To Start The System Or Make Calibrations, Please Read The Following Information Carefully.

During startup and calibration, you will be bleeding the system of air and checking for possible leaks throughout the system. Provisions should be made for collection or clean-up of spilled fluid. Attempts should be made to minimize losses during these procedures. If the additive being handled is flammable, fire safety precautions should be taken.

A WORD ABOUT ADDITIVES

Most additives being used in fuels today have at least some degree of toxicity. Many are very dangerous. Extreme caution should be taken in handling additives. Remember, the additive is placed under pressure when being injected into the line. Be careful; wear protective clothing including eye protection. Be sure you have facilities to wash off any additive that may

come in contact with your skin. Read all additive manufacturers safety precautions and Material Safety Data Sheets, following them to the letter.

HERE IS WHAT IS NEEDED:

- Appropriate safety protection equipment.
 - Eye protection in the form of safety goggles.
 - A marked graduated glass bottle that is marked in either cc's or ounces. (At least 16 oz.)
 - A stop watch.
 - A means of determining the flow rate of the main system.
 - A small pocket calculator is helpful.
 - A clipboard is helpful with pad of paper.
- AT LEAST ONE AND PREFERABLY TWO HELPERS**

REMEMBER: Any plumbing system varies with temperature and fluid being pumped. The system also changes as parts of the pump wear.

Hammonds Model PHC1 600-1 Portable Hand Cart Manual

CALIBRATION AND STARTUP

IF YOUR INJECTOR SYSTEM IS EQUIPED WITH CALIBRATION GAUGES, FOLLOW THE INSTRUCTIONS FOR THEIR USE IN THE BACK OF THIS MANUAL.

PROPER ADDITIVE INJECTION RATIOS

Although volumetric calibration at atmospheric pressure will bring you within an acceptable range of additive injection, the only true evaluation for proper ratio is the ASTM D-5006 evaluation for fuel system ice inhibitor (FSII). Do not depend on volumetric calibration to ensure on-spec performance because line pressures can vary and additive injector parts wear over time. Contact Hammonds Fuel Additives, Inc. for supply of quality fuel system ice inhibitor and fuel testing procedures.

Please Follow These Steps In Their Given Order. Read Them Over Carefully Before Starting, Then Follow Them To The Letter. If There is Any Part Of The Procedure That Is Not Clear, Consult Your Local Distributor Or The Factory Directly.

1. The system must be grounded. Your system may be equipped with a ground clamp or bayonet plug for static grounding purposes. If using the bayonet plug, there is a grounding receiver lug located on the upper cross member on the cart.
2. Make certain the additive pail is at least $\frac{1}{4}$ full of the proper additive.
3. With the suction valve closed on the 5SF at the pail, connect the hose from the pump to the 5SF with the quick disconnect.

Make certain that the coupling is fully connected.

4. Open the valve on the 5SF and at the inlet to the pump.
5. Remove the rubber cap from the desiccant dryer hanging from the 5SF.
6. All systems are calibrated at the factory to customer specified requirements. So if adjustments are required, they should only be minor. If this is the case, go directly to step 8.
7. If you are starting from scratch in the calibration and adjustment, loosen the stroke adjustment locking screws located on the bottom of the pump body directly under the stroke adjustment knob. This will allow the stroke adjustment to be moved.
8. Adjust the stroke adjustment knobs located on the pump face to approximately 50%. **CAUTION:** Do not turn these adjustments with excessive force. If they are difficult to adjust, simply rotate the main rotor shaft, by producing flow in main product line. Lock the stroke adjustment locking screws down firmly.
9. Set the calibration valve (3-way valve) in the "calibrate or bleed position." This is done by making certain that the handle on the valve is positioned so that additive will exit through the short open tube.
10. Make certain all product connections going to and from the system are in their proper, locked position to ensure safe, leak proof flow of product through the fluid motor. Double check the flow direction arrows located on the fluid motor housing, and check valves before and after

Hammonds Model PHC1 600-1 Portable Hand Cart Manual

the pump to ensure that the system is installed properly.

11. At this point, consider the information you will have to gather during the next few steps of the calibration process.

A. What will the flow rate through the unit be?

B. What is the length of time that the calibration will cover?

C. What is the amount of additive in ounces or cc's that you will need to collect based on the duration of the calibration.

You Should Have the Answer To All Of These Questions Before Your First Trial Run.

12. Before starting the main product flow through the system, make certain everyone understands that you will run the system for, let's say, one (1) minute. Even shorter runs are fine, especially if you are running at high flow rates.

10. Place the measured graduate under the calibration tube. Put on your eye protection.

11. At the command of the time keeper, or that person watching the flow meter, start the main product pumps.

12. Give the system a few seconds to gather momentum and flow through the fluid motor. Notice if the additive injector system is turning. The bearing on the shaft under the stroke adjustment knob cover should be spinning.

13. If the pump is being started up for the first time, it will take a few seconds to prime itself and begin discharging fluid from the

calibration tube. Is your eye protection on? If not, **PUT IT ON NOW!**

14. As soon as the pump begins discharging a clear, air free stream of fluid from the calibration tube, you are ready to begin your calibration. At this point, the system is primed. ***Hammonds recommends using the Pressure Simulating Calibration Device, an optional accessory item, to duplicate system pressure during calibration.**

15. You will now prepare to make your first actual calibration run. Empty your collected additive back into the tank, putting the bottle back under the calibration tube. Notice the setting on the main product meter, set your stop watch at zero.

16. When ready, start the system again. Stop it at the decided time interval or meter reading. Calculate the amount of product that traveled through the system. Measure the amount of additive gathered, and record the amount of elapsed time.

17. It will be at this time that you will have to calculate how much additive you should have collected for the amount of fuel that the system pumped. This, of course, depends upon the ratio that is required. The following example is the easiest way of explaining the procedure without getting too complicated. It is not the only way...use it if you like.

Example condition: Amount of product pumped: 500 gallons

Ratio of additive desired: 250 PPM (Parts per million)

It is assumed that the operator will know how much product is being pumped through the system in a given length of

Hammonds Model PHC1 600-1 Portable Hand Cart Manual

time. If, for example, you have a meter that registers the flow in gallons, you simply record the gallons at the beginning of the timed run, and then again at the end of the run. If you run for one (1) minute, you simply subtract the beginning number on the meter from the number registered after the run. This will give you the gallons per minute (GPM). Having to make this calculation is the only reason for timing the run. You can accomplish the same result by just watching the meter and stopping the system when you have totaled the desired amount of gallons through the system. In any case, you must know the amount of product passing through the system before calibration can begin.

First, change the gallons pumped into ounces by multiplying total gallons (in our example 500) by 128 (128 oz. to a gallon). The answer is 64,000 ounces.

Second, divide by 1,000,000. The answer is .064. Since you are dealing in 1/1,000,000 (one part per million) of the total for your ratio, you must find out what 1/1,000,000 of the 500 gallons is, .064 ounces is 1/1,000,000th (one part per million) of 500 gallons.

Third, multiply the .064 x 250 (for 250 PPM ratio). The answer is 16 ounces.

So, you should collect 16 ounces of additive for every 500 gallons of fuel pumped.

These are all large, round numbers. You may, for example, only be running at 100 GPM, not 500. Use the same procedure; just change the numbers to fit your application.

No two systems will ever perform exactly the same. For this reason, the procedures

given for calibration are general in nature. Obviously, it is impossible to provide a graph or table that would be absolutely accurate in every case. With that in mind, all tables and graphs should be used as general guidelines. Remember, the calculated, timed and measured output that you gather is absolute. Trust your figures and your calculations.

NORMAL OPERATION

Following initial start up and calibration, the system requires very little attention other than making certain that additive tank levels are maintained. Operators will quickly become accustomed to the performance of the system by observing the Calibration Gauge glass or Sight Flow Indicator. On-spec injection will cause a certain response in the indicators, and with some practice, operators will be able to observe the system at a glance. *This does not mean that system calibration should not be periodically checked!* However, during a busy workload, these visual checks will provide assurance to the operator that the system is functioning.

Assuming the system remains set up and operating at least intermittently, calibration is required perhaps every 1 – 3 months. Good record keeping of additive inventory and use levels compared to fuel handled can give a good indication that additive is on specification. Test such as the refractometer for FSII content should be the final test to verify additive injection ratios.

Hammonds Model PHC1 600-1 Portable Hand Cart Manual

SAMPLE ADDITIVE CHART

GALLONS	135 PPM	270 PPM	1000 PPM
100	1.7 OZ.	3.4 OZ.	12.8 OZ.
200	3.4 OZ.	6.9 OZ.	25.6 OZ.
400	6.9 OZ.	13.8 OZ.	51.2 OZ.
500	8.6 OZ.	17.2 OZ.	64.0 OZ.
700	12.0 OZ.	24.0 OZ.	89.6 OZ.
1000	17.2 OZ.	34.5 OZ.	128.0 OZ.

TROUBLESHOOTING THE SYSTEM

The following conditions are given as a means of troubleshooting the system. Each condition lists a number of possible causes. In most cases, trouble can be solved by the use of this section. Please read it carefully before attempting repairs or making changes in the system.

FLUID MOTOR IS NOT TURNING

- A. Insufficient flow to turn the motor. A minimum flow of about 20 GPM is needed to start the system.
- B. A rag or some other object is jammed in the line preventing the fluid motor from turning.
- C. A diverter valve is blocked downstream of the system, blocking the fuel flow through the system.
- D. A valve is closed upstream of the fluid motor starving the product flow.
- E. If the unit has been recently serviced internally, or it is new, the rotor might be installed backwards. Consult the factory before disassembly.

INJECTOR IS TURNING AND PUMP IS RUNNING, BUT WITH NO OUTPUT

- A. Pump is air-locked. In some cases where there is a very long line running from the injector head and the point of injection into the system, there is sufficient air volume to cause the pump to act as a compressor. It is not able to open the valves throughout the system and therefore, cannot pull a suction of fluid to the pump. Loosen the connection at the injection point check valve and allow it to remain open until the pump begins pumping. This is rare, but can happen in some cases of unusual installations.
- B. One or more of the suction or discharge check valves are not working. While the pump is running, tap on the side of the valves, one at a time. This will generally jar them loose. The poppet/seal is very small, and will sometimes become stuck. After the valve is loosened and has a supply of fluid, usually it will not stick again.
- C. The pump is not getting additive. Check that the valve between the pump and the tank is open. Check all connections in the line between the pump and the tank.

Hammonds Model PHC1 600-1 Portable Hand Cart Manual

- D. The vent on the pail is not open causing the pump to pull a vacuum. Open the vent. Check to see if the cap has been removed from the dryer cartridge, if so equipped.
- E. The pump stroke is set at zero. Check to see if the locking screws have been left loose, allowing the adjustment knobs to rotate to zero percent (0%) of stroke.
- F. The additive pail is empty...don't laugh, it happens.

THE INJECTOR IS OPERATING BUT WITH REDUCED OUTPUT

- A. Leaking suction line or trash in one of the pump check valves.
- B. Air leak in suction side of system.

- C. Defective tubing or piping on suction side.
- D. Leaks in threaded connections - suction side.
- E. Injector diaphragm may be pulled out in back causing injector to pump in forward portion of stroke only. This will not create a visible leak but will reduce output by 50%. It usually happens after many hours of operation.
- F. If equipped with a plunger pump, the plunger seal (o-ring) may be worn and needs replacing. Also, check plunger for signs of wear, replace if necessary.
- G. Fluid motor vanes are badly worn. This would only be probable after a very high number of hours of operation.

PREVENTIVE MAINTENANCE

1. Make certain to use only clean, fresh additive that has been stored in a sealed container. Most additives are moisture sensitive. Some will form heavy crystals if allowed to accumulate moisture. These crystals will stop the pump in very short order, if not cause calibration to be changed due to clogging of the valves and other parts.
2. Check the additive filter screen at least every six months. More often if there is an indication of possible contamination.
3. Check the system for leaks at every use. This is an extremely important safety procedure, since some additives are flammable, caustic and corrosive.
4. Check for leaks from the seal that is located at the exit point of the injector output shaft in the side plate housing. This should be done at each operation. Leakage at this point usually indicates that

- the mechanical seal inside the rotor housing is leaking. A leak here will be fuel, and is not only dangerous from a fire standpoint, but will quickly ruin the bearings on the rotor shaft, since all lubricant will be washed away.
5. Check the fittings for leakage around the Calibration Gauge or Sight Flow Indicator, if one is used on the pump. Check this fitting each time the filter is changed or cleaned. Make certain there are no leaks in the suction line. A very small leak will either change the operation of the pump or prevent it from operating altogether.
 6. Visually check around the pump head and make certain there is no leaking of additive around the fluid ends. If there is, check the tightness of the head bolts. (40 inch pounds each).
 7. Check the grease around the eccentric drive bearing in the pump every 6 months. Use a good quality white lithium spray lubricant.

Hammonds Model PHC1 600-1 Portable Hand Cart Manual

8. It is recommended that the injector diaphragm or plunger o-ring be changed at least every 12 months. Every 6 months under extreme operating conditions. Doing so will prevent unexpected failures and unscheduled downtime.

Hammonds injectors are very dependable. If installed properly and sized appropriately to the application, they require very little maintenance. With the exception of the grease on the eccentric bearing mentioned in STEP 7, there is very little actual maintenance to do. Remember; keep the additive clean, and the suction filter clean. If you have problems with the

pump working, it is usually in the suction side of the system (between the injection pump and the additive pail). Suction lines and fittings are notorious for leaking just enough to prevent the system from working. Always check to ensure optimum suction conditions should problems occur.

Remember, a leak in the suction allows air from the outside to be introduced into the system. It does not always mean a visible leak of additive. If the pump loses its prime or output is erratic, chances are good that there are problems in the suction side. Otherwise, if it is working...leave it alone!!!!

PREVENTATIVE MAINTENANCE SCHEDULE

NOTE: It is important to read the previous pages on preventative maintenance. These intervals are general, and may vary according to individual applications and severity of service.

SERVICE FUNCTION	0-4 HRS DAILY	5-8 HRS DAILY	8+HRS DAILY
Check additive filter screen in Sight Flow	Monthly	Monthly	Monthly
Check system for additive/fuel leaks	Daily	Daily	Daily
Inspect diaphragms/plunger seals	12 Months	6 Months	3 Months
Replace diaphragms/plunger seals	12 Months	As needed	As needed
Check eccentric bearing grease	6 Months	3 Months	Monthly
Check stroke adjustment parts for looseness	Monthly	Monthly	Monthly
Replace stroke adjustment parts	24 Months	As needed	As needed
Disassemble and inspect turbine housing and internal parts	24 Months	12 Months	8 Months
Grease bearings	12 Months	6 Months	3 Months

Hammonds Model PHC1 600-1 Portable Hand Cart Manual

DESICCANT DRYER

Your Hammonds Additive Injector Cart includes 1 or more additive tanks. These tanks may come equipped with a desiccant dryer cartridge. These dryers come in several different sizes.

Most systems are equipped with the standard 3/4" cartridge. This unit is attached to the tank via a short length of black rubber hose. The cartridge has a housing constructed of a clear poly material and is filled with a blue colored desiccant crystal. All these units are shipped from the factory with a small yellow cap on the each end of the cartridge.

Some systems may come equipped with a large canister measuring approximately 2" diameter and 10" in length. These units perform the same function, just on a larger scale. Due to their greater capacity, they last longer between service. These units are sealed from the factory by a small, plastic plug which is located either on the bottom or one side of the canister.

The purpose of all desiccant dryers is simply to remove moisture from the air as the system breathes. All tanks or portable sources of additive supply must be vented to atmosphere in order for the injector to operate. If moisture in this venting air is not removed, some additives are either ruined or seriously damaged. Fuel system icing inhibitor (FSII), for example, is designed to seek out water in a fluid. So, when enough moisture is absorbed into the container, the FSII is diluted and at some point will be ruined. Biobor® JF, an anti-fungal material, will form crystals in the presence of moisture and not only perform

unsatisfactorily as an additive, but will stop up pumps and lines as well.

The following instructions apply to all desiccant cartridges:

A. Remove the caps or plugs when the system is placed into service.

B. Observe the color of the desiccant. The original color is blue. As moisture is absorbed, the color will change to pink. When the cartridge is completely pink, it should either have its contents removed, dried and replaced, or the entire unit replaced.

C. **NOTE:** The contents can be removed from plastic container, placed on a pan and baked at 400°F in a conventional oven until the moisture has been removed. When the color blue returns, the cooled material may be reinstalled into plastic containers and is again ready for service.

D. Color change and cartridge life is totally dependent on humidity. The more moist the air, the shorter the life. Keeping it dry is especially important if additive is not consumed rapidly. Check daily and service as needed.

Hammonds Model PHC1 600-1 Portable Hand Cart Manual

Page intentionally left blank.

Hammonds Model PHC1 600-1 Portable Hand Cart Manual

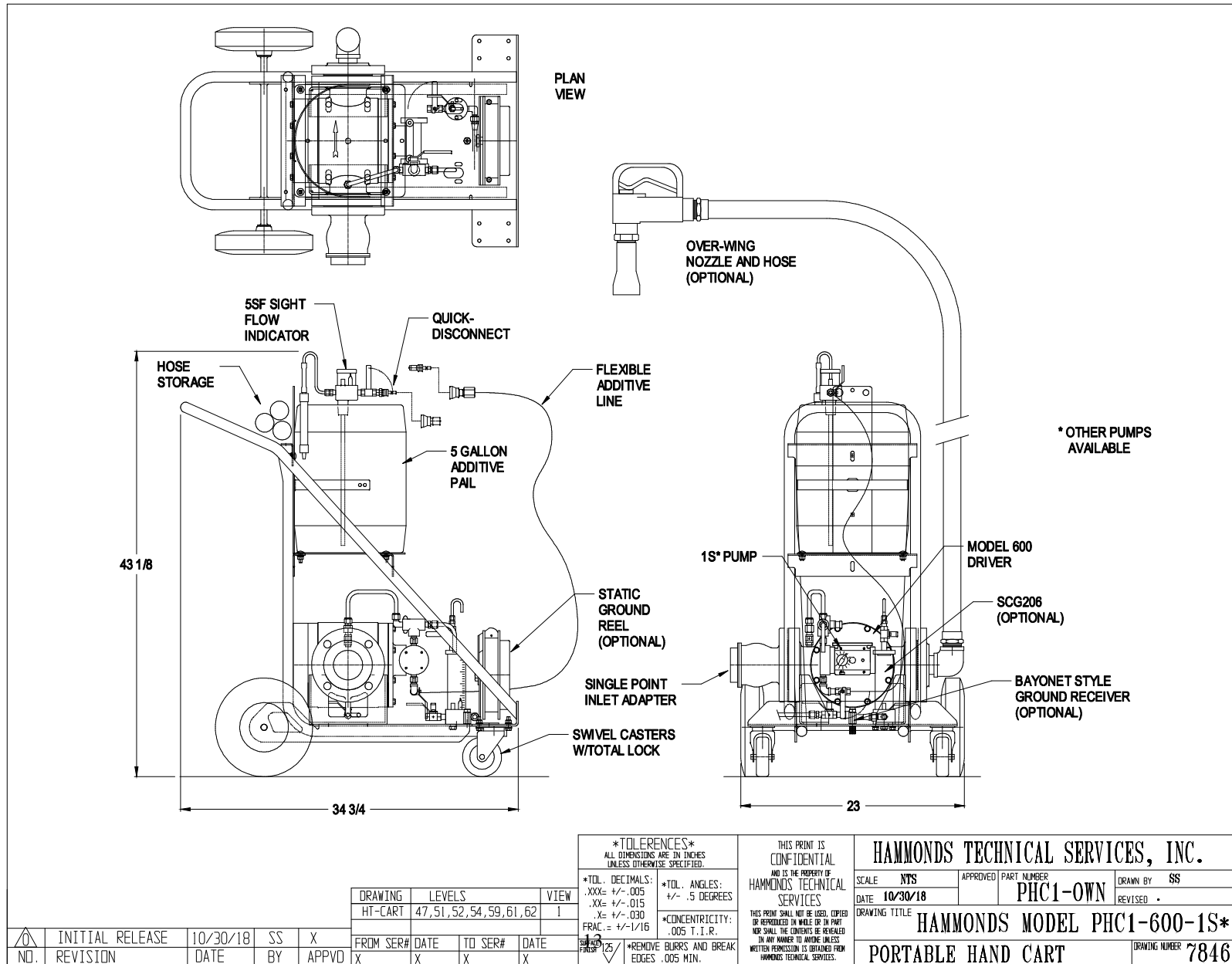

<table border="1" style="width: 100%; border-collapse: collapse;"> <tr> <td style="width: 25%;">DRAWING</td> <td style="width: 50%;">LEVELS</td> <td style="width: 25%;">VIEW</td> </tr> <tr> <td>HT-CART</td> <td>47,51,52,54,59,61,62</td> <td>I</td> </tr> </table>				DRAWING	LEVELS	VIEW	HT-CART	47,51,52,54,59,61,62	I	<p>*TOLERANCES* ALL DIMENSIONS ARE IN INCHES UNLESS OTHERWISE SPECIFIED.</p>		<p>THIS PRINT IS CONFIDENTIAL AND IS THE PROPERTY OF HAMMONDS TECHNICAL SERVICES</p> <p>THIS PRINT SHALL NOT BE USED, COPIED OR REPRODUCED IN WHOLE OR IN PART NOR SHALL THE CONTENTS BE RELEASED IN ANY MANNER TO ANYONE UNLESS WRITTEN PERMISSION IS OBTAINED FROM HAMMONDS TECHNICAL SERVICES.</p>		<p>HAMMONDS TECHNICAL SERVICES, INC.</p>		
				DRAWING	LEVELS	VIEW										
HT-CART	47,51,52,54,59,61,62	I														
<p>*TOL. DECIMALS: .XXX= +/- .005 .XX= +/- .015 .X= +/- .030 FRAC. = +/- 1/16</p>		<p>*TOL. ANGLES: +/- .5 DEGREES</p>		<p>SCALE: NTS</p>	<p>APPROVED PART NUMBER</p>	<p>DRAWN BY: SS</p>										
<table border="1" style="width: 100%; border-collapse: collapse;"> <tr> <td style="width: 25%;">NO.</td> <td style="width: 25%;">REVISION</td> <td style="width: 25%;">DATE</td> <td style="width: 25%;">BY</td> </tr> <tr> <td> </td> <td> </td> <td> </td> <td> </td> </tr> </table>				NO.	REVISION	DATE	BY					<p>*CONCENTRICITY: .005 T.I.R.</p>		<p>DATE: 10/30/18</p>	<p>PART NUMBER: PHC1-OWN</p>	<p>REVISED: .</p>
NO.	REVISION	DATE	BY													
<table border="1" style="width: 100%; border-collapse: collapse;"> <tr> <td style="width: 25%;">FROM SER#</td> <td style="width: 25%;">DATE</td> <td style="width: 25%;">TO SER#</td> <td style="width: 25%;">DATE</td> </tr> <tr> <td>X</td> <td>X</td> <td>X</td> <td>X</td> </tr> </table>				FROM SER#	DATE	TO SER#	DATE	X	X	X	X	<p>*REMOVE BURRS AND BREAK EDGES .005 MIN.</p>		<p>DRAWING TITLE: HAMMONDS MODEL PHC1-600-1S*</p>		
FROM SER#	DATE	TO SER#	DATE													
X	X	X	X													
						<p>PORTABLE HAND CART</p>		<p>DRAWING NUMBER: 7846</p>								

Hammonds Model PHC1 600-1 Portable Hand Cart Manual

PLAN
VIEW

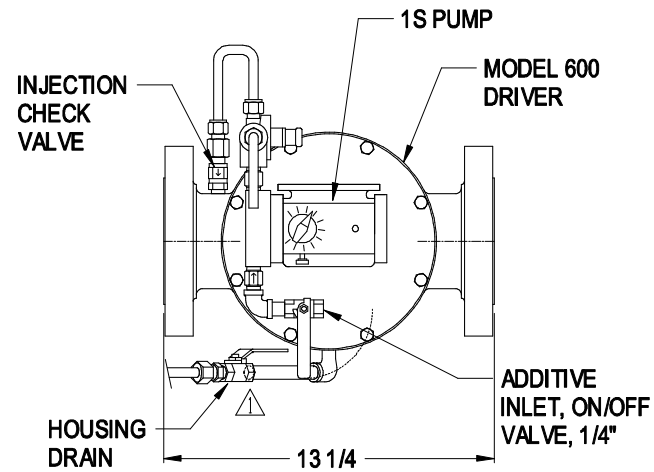
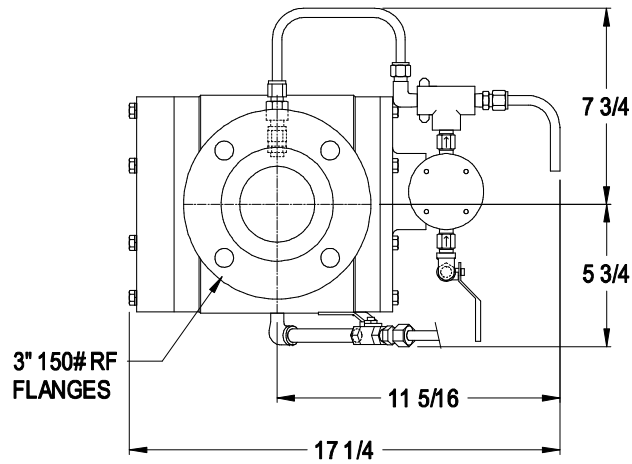
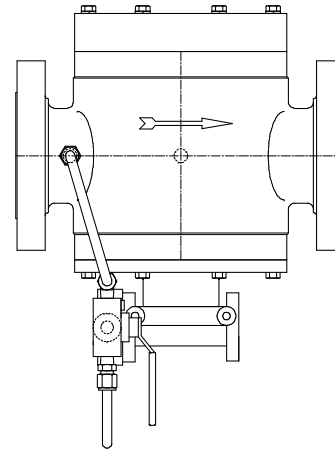

<table border="1" style="width: 100%; border-collapse: collapse;"> <tr> <td style="width: 25%;">DRAWING</td> <td style="width: 25%;">LEVELS</td> <td style="width: 25%;">VIEW</td> <td style="width: 25%;"></td> </tr> <tr> <td>HT-CART</td> <td>38, 39</td> <td>I</td> <td></td> </tr> </table>				DRAWING	LEVELS	VIEW		HT-CART	38, 39	I		<p>*TOLERANCES* ALL DIMENSIONS ARE IN INCHES UNLESS OTHERWISE SPECIFIED.</p>		<p>THIS PRINT IS CONFIDENTIAL AND IS THE PROPERTY OF HAMMONDS TECHNICAL SERVICES</p>		<p style="text-align: center;">HAMMONDS TECHNICAL SERVICES, INC.</p>		
				DRAWING	LEVELS	VIEW												
HT-CART	38, 39	I																
<p>*TOL. DECIMALS: .XXX= +/- .005 .XX= +/- .015 .X= +/- .030 FRAC.= +/- 1/16</p>		<p>*TOL. ANGLES: +/- .5 DEGREES</p>		<p>SCALE: NTS</p>	<p>APPROVED PART NUMBER</p>	<p>DRAWN BY: SS</p>												
<table border="1" style="width: 100%; border-collapse: collapse;"> <tr> <td style="width: 25%;">NO.</td> <td style="width: 25%;">REVISION</td> <td style="width: 25%;">DATE</td> <td style="width: 25%;">BY</td> <td style="width: 25%;">APPVD</td> </tr> <tr> <td></td> <td></td> <td></td> <td></td> <td></td> </tr> </table>				NO.	REVISION	DATE	BY	APPVD						<p>FROM SER# DATE TO SER# DATE</p>		<p>DATE: 11/03/17</p>		<p>REVISER: 03/19/18</p>
NO.	REVISION	DATE	BY	APPVD														
				<p>SURFACE FINISH: 125 REMOVE BURRS AND BREAK EDGES .005 MIN.</p>		<p>*CONCENTRICITY: .005 T. I. R.</p>		<p>DRAWING TITLE: HAMMONDS MODEL 600-1S</p>										
						<p>FOR PHC-HAND CART</p>		<p>DRAWING NUMBER: 6734-1</p>										

Hammonds Model PHC1 600-1 Portable Hand Cart Manual

ITEM	PART NO.	QTY.	DESCRIPTION
1	101045	1	SNAP RING
2	881157	1	PUMP DRIVE BEARING
3	881629	1	SPACER
4	881120	2	BEARING
5	881121	2	SNAP RING
6	881119	3	SNAP RING
7	882011	1	PUMP SIDE PLATE
8	212001	1	SHAFT
9	212002	2	KEY, 3/16" SQ. x1"
10	141006	1	MECH. SEAL, VITON, STD
	141048	1	MECH. SEAL, BUNA (OPT)
	141009	1	MECH. SEAL, HP (OPT)
11	882012	2	WEAR RING
12	212097	6	VANE, TEFLON
13	212006	1	ROTOR
14	881910	2	O RING, VITON
	881154	2	O RING, BUNA-N (OPT)
15	212008	1	HOUSING, 3" VC.
	212250	1	HOUSING, 3" 150#
16	151005	1	PIPE PLUG, 1/4"
17	212272	1	BEARING, SHIELDED
18	212473	1	BACK PLATE, HD
19	881124	16	LOCKWASHER, 5/16"
20	881125	8	BOLT, 5/16" x 1"
21	881289	8	BOLT, 5/16" x 2 1/4"

NO.	REVISION	DATE	BY	APPVD	DRAWING	LEVELS	VIEW
2	ADDED BUNA-N OPT	12/10/14	SS	X	600DRVR	140, 151, 153-156, 158,	1
1	ADDED HP SEAL OPT	01/15/14	SS	X			
0	INITIAL RELEASE	02/18/08	SS	X			
					FROM SER#	DATE	TO SER#
					X	X	X

TOLERANCES
ALL DIMENSIONS ARE IN INCHES UNLESS OTHERWISE SPECIFIED.

*TOL. DECIMALS:
.XXX= +/- .005
.XX= +/- .015
.X= +/- .030
FRAC.= +/- 1/16

*TOL. ANGLES:
+/- .5 DEGREES

*CONCENTRICITY:
.005 T.I.R.

REMOVE BURRS AND BREAK EDGES .005 MIN.

THIS PRINT IS CONFIDENTIAL AND IS THE PROPERTY OF HAMMONDS TECHNICAL SERVICES

THIS PRINT SHALL NOT BE LOANED, COPIED OR REPRODUCED IN WHOLE OR IN PART NOR SHALL THE CONTENTS BE REVEALED IN ANY MANNER TO ANYONE UNLESS WRITTEN PERMISSION IS OBTAINED FROM HAMMONDS TECHNICAL SERVICES.

HAMMONDS TECHNICAL SERVICES, INC.	
SCALE: NTS	APPROVED PART NUMBER: .
DATE: 02/18/08	DRAWN BY: SS
DRAWING TITLE: MODEL 600 DRIVER	
EXPLODED VIEW	DRAWING NUMBER: 5833

Hammonds Model PHC1 600-1 Portable Hand Cart Manual

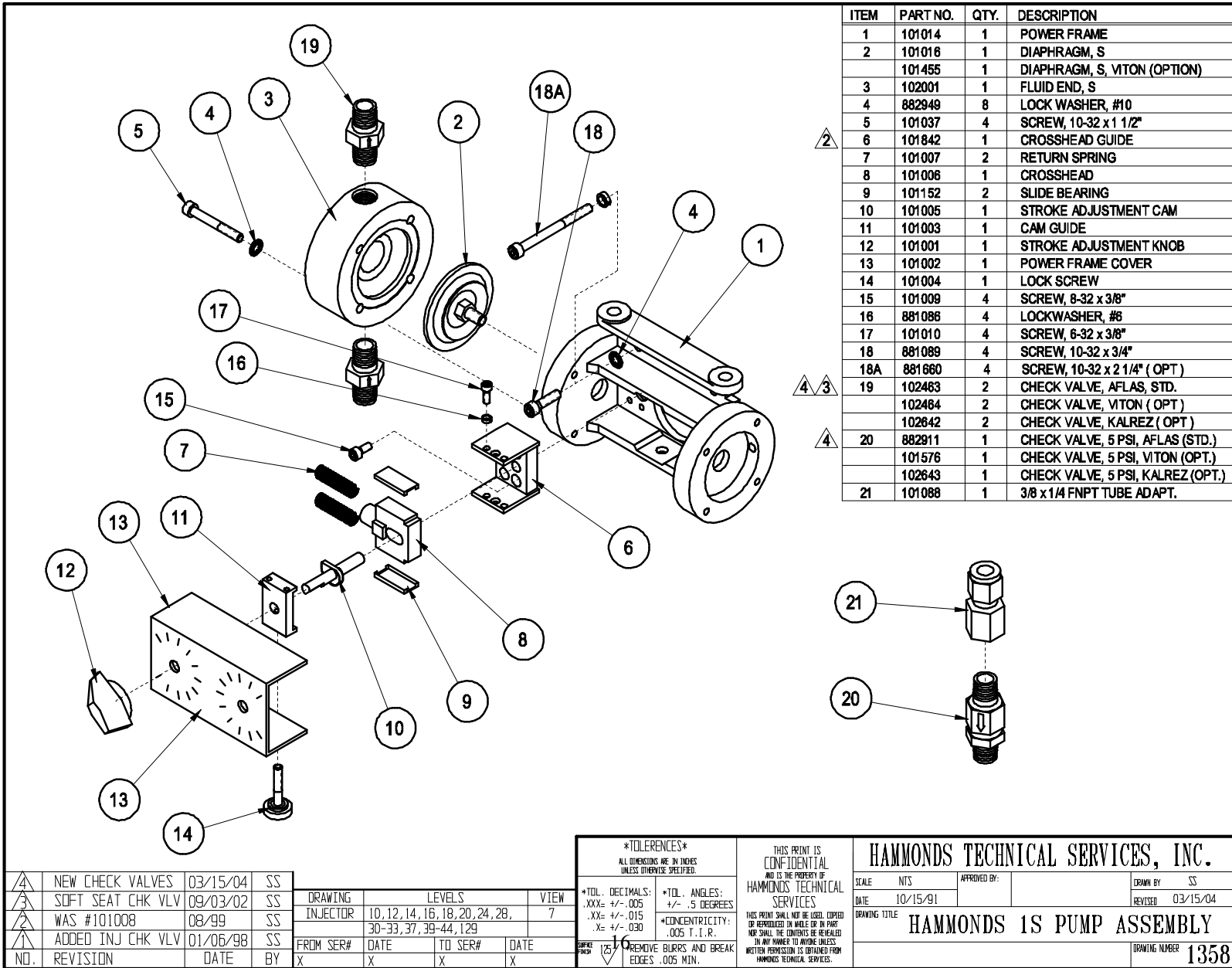

ITEM	PART NO.	QTY.	DESCRIPTION
1	101014	1	POWER FRAME
2	101016	1	DIAPHRAGM, S
	101455	1	DIAPHRAGM, S, VITON (OPTION)
3	102001	1	FLUID END, S
4	882949	8	LOCK WASHER, #10
5	101037	4	SCREW, 10-32 x 1 1/2"
6	101842	1	CROSSHEAD GUIDE
7	101007	2	RETURN SPRING
8	101006	1	CROSSHEAD
9	101152	2	SLIDE BEARING
10	101005	1	STROKE ADJUSTMENT CAM
11	101003	1	CAM GUIDE
12	101001	1	STROKE ADJUSTMENT KNOB
13	101002	1	POWER FRAME COVER
14	101004	1	LOCK SCREW
15	101009	4	SCREW, 8-32 x 3/8"
16	881086	4	LOCKWASHER, #6
17	101010	4	SCREW, 6-32 x 3/8"
18	881089	4	SCREW, 10-32 x 3/4"
18A	881660	4	SCREW, 10-32 x 2 1/4" (OPT)
19	102483	2	CHECK VALVE, AFLAS, STD.
	102484	2	CHECK VALVE, VITON (OPT)
	102642	2	CHECK VALVE, KALREZ (OPT)
20	882911	1	CHECK VALVE, 5 PSI, AFLAS (STD.)
	101576	1	CHECK VALVE, 5 PSI, VITON (OPT.)
	102643	1	CHECK VALVE, 5 PSI, KALREZ (OPT.)
21	101088	1	3/8 x 1/4 FNPT TUBE ADAPT.

△	NEW CHECK VALVES	03/15/04	SS
△	SOFT SEAT CHK VLV	09/03/02	SS
△	WAS #101008	08/99	SS
△	ADDED INJ CHK VLV	01/06/98	SS
NO.	REVISION	DATE	BY

DRAWING	LEVELS	VIEW
INJECTOR	10, 12, 14, 16, 18, 20, 24, 28, 30-33, 37, 39-44, 129	7
FROM SER#	DATE	TO SER#
X	X	X

TOLERANCES
ALL DIMENSIONS ARE IN INCHES UNLESS OTHERWISE SPECIFIED.

*TOL. DECIMALS:	*TOL. ANGLES:
.XXX= +/- .005	+/- .5 DEGREES
.XX= +/- .015	*CONCENTRICITY:
.X= +/- .030	.005 T. I. R.

REMOVE BURRS AND BREAK EDGES .005 MIN.

THIS PRINT IS CONFIDENTIAL AND IS THE PROPERTY OF HAMMONDS TECHNICAL SERVICES

THIS PRINT SHALL NOT BE USED, COPIED OR REPRODUCED IN WHOLE OR IN PART NOR SHALL THE CONTENTS BE REVEALED IN ANY MANNER TO ANYONE UNLESS WRITTEN PERMISSION IS OBTAINED FROM HAMMONDS TECHNICAL SERVICES.

HAMMONDS TECHNICAL SERVICES, INC.			
SCALE	NTS	APPROVED BY:	DRAWN BY SS
DATE	10/15/91		REVISED 03/15/04
DRAWING TITLE:		HAMMONDS 1S PUMP ASSEMBLY	
			DRAWING NUMBER 1358

Hammonds Model PHC1 600-1 Portable Hand Cart Manual

*** WARNING... FAILURE TO TORQUE SCREWS PROPERLY TO 40 IN. LBS. WILL REDUCE PUMP HEAD PERFORMANCE, RESULTING IN INSUFFICIENT INJECTION RATIO.**

11 REINSTALL SCREWS, TAKING EACH ONE DOWN BY HAND UNTIL IT STOPS. TIGHTEN SCREWS TO 40 IN. LBS. * IN THE ORDER SHOWN BELOW. TORQUE EACH SCREW IN THE PATTERN, THEN REPEAT THE TORQUE SEQUENCE ONLY ONCE!

12 ROTATE DIAL COUNTER CLOCKWISE ENOUGH TO INSTALL DRIVE BEARING. INSTALL SNAP RING.

13 REMOVE DIAL KNOB. REINSTALL PLASTIC COVER. REINSTALL DIAL KNOB AND POSITION IT ON ORIGINAL % SETTING. INSTALL LOCK SCREW, LOCK DIAL IN PLACE. NOTE: AFTER THIS PROCEDURE IS COMPLETE, YOU MUST RECALIBRATE THE INJECTOR TO YOUR SPECIFICATIONS.

FOR TECHNICAL ASSISTANCE CALL
HAMMONDS TECHNICAL SERVICES
(281) 999-2900

HAMMONDS TECHNICAL SERVICES, INC.

SCALE	NTS	APPROVED BY:	DRAWN BY
DATE	2/11/92		REVISED 4/10/92
DRAWING TITLE		"S" DIAPHRAGM REPLACEMENT	
			DRAWING NUMBER
			1459

Hammonds Model PHC1 600-1 Portable Hand Cart Manual

ITEM	PART NO.	QTY.	DESCRIPTION
1	101014	1	POWER FRAME
2	102266	1	PLUNGER, P2
3	102267	1	FLUID END, P2
4	882949	8	LOCK WASHER, #10 INT. TOOTH
5	881780	4	SCREW, 10-32 x 2 3/4"
6	101842	1	CROSSHEAD GUIDE
7	101007	2	RETURN SPRING
8	101006	1	CROSSHEAD
9	101152	2	SLIDE BEARING
10	101005	1	STROKE ADJUSTMENT CAM
11	101003	1	CAM GUIDE
12	101001	1	STROKE ADJUSTMENT KNOB
13	101002	1	POWER FRAME COVER
14	101004	1	LOCK SCREW
15	101009	4	SCREW, 8-32 x 3/8"
16	881086	4	LOCKWASHER, #6
17	101010	4	SCREW, 6-32 x 3/8"
18	881089	4	SCREW, 10-32 x 3/4"
* 18A	881660	4	SCREW, 10-32 x 2 1/4" (OPTION)
19	102783	2	CHECK VALVE, 1/8", VITON
20	102269	1	O-RING, AFLAS
* 20A	102270	1	O-RING, VITON (OPTION)
21	102268	1	SEAL HOUSING, P2
22	881024	1	SEAL LIP
23	881045	1	SETScrew, 1/4-20 x 1"
24	882911	1	CHECK VALVE, 5 PSI, AFLAS
	101576	1	CHECK VALVE, 5 PSI, VITON (OPTION)
25	101058	1	1/4 x 1/4 FNPT TUBE ADAPT.

TOLERANCES
ALL DIMENSIONS ARE IN INCHES UNLESS OTHERWISE SPECIFIED.

*TOL. DECIMALS: .XXX = +/- .005 .XX = +/- .015 .X = +/- .030 FRAC. = +/- 1/16	*TOL. ANGLES: +/- .5 DEGREES
*CONCENTRICITY: .005 T. I. R.	
REMOVE BURRS AND BREAK EDGES .005 MIN.	

THIS PRINT IS CONFIDENTIAL AND IS THE PROPERTY OF HAMMONDS TECHNICAL SERVICES

THIS PRINT SHALL NOT BE LOANED, COPIED OR REPRODUCED IN WHOLE OR IN PART IN ANY MANNER TO AVOID UNLESS WRITTEN PERMISSION IS OBTAINED FROM HAMMONDS TECHNICAL SERVICES.

HAMMONDS TECHNICAL SERVICES, INC.		SCALE: NTS	APPROVED: _____	PART NUMBER: _____	DRAWN BY: SS
		DATE: 06/20/95			REVISED: 02/20/08
		DRAWING TITLE: HAMMONDS 1P2 PUMP			
		DRAWING NUMBER: 4567			

NO.	REVISION	DATE	BY	APPVD	DRAWING	LEVELS	FROM SER#	DATE	TO SER#	DATE
1	WAS #102463	02/20/08	SS	X	INJECTOR	10, 12, 14, 16, 18, 20, 24, 28				
2	WAS #101933	03/15/04	SS	X						

Hammonds Model PHC1 600-1 Portable Hand Cart Manual

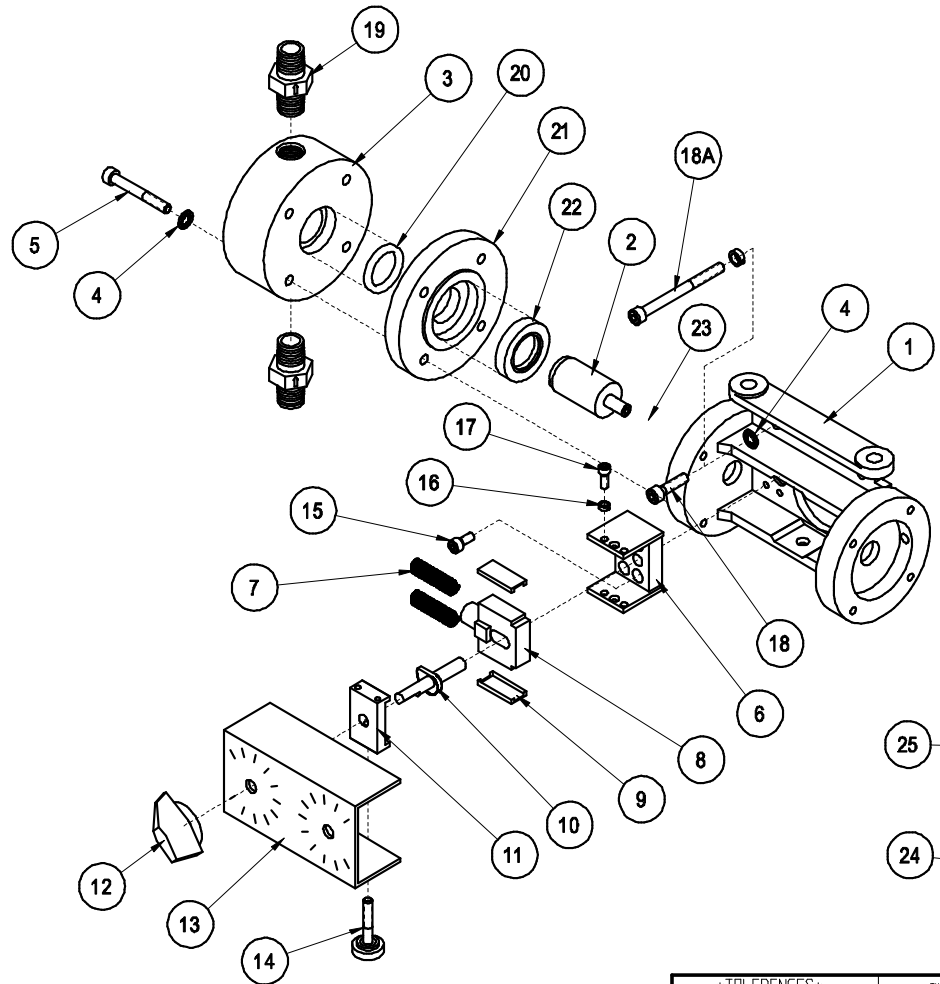

ITEM	PART NO.	QTY.	DESCRIPTION
1	101014	1	POWER FRAME
2	102339	1	PLUNGER, P5
3	102340	1	FLUID END, P5
4	882949	8	LOCK WASHER, #10 INT. TOOTH
5	881317	4	SCREW, 10-32 x 2"
6	101842	1	CROSSHEAD GUIDE
7	101007	2	RETURN SPRING
8	101006	1	CROSSHEAD
9	101152	2	SLIDE BEARING
10	101005	1	STROKE ADJUSTMENT CAM
11	101003	1	CAM GUIDE
12	101001	1	STROKE ADJUSTMENT KNOB
13	101002	1	POWER FRAME COVER
14	101004	1	LOCK SCREW
15	101009	4	SCREW, 8-32 x 3/8"
16	881086	4	LOCKWASHER, #6
17	101010	4	SCREW, 6-32 x 3/8"
18	881089	4	SCREW, 10-32 x 3/4"
18A	881660	4	SCREW, 10-32 x 2 1/4" (OPTION)
▲1	19	102463	2 CHECK VALVE, AFLAS, STD.
		102464	2 CHECK VALVE, VITON (OPTION)
▲3		102642	2 CHECK VALVE, KALREZ (OPTION)
	20	101856	1 O-RING, AFLAS
		101857	1 O-RING, VITON (OPTION)
▲3		103514	1 O-RING, KALREZ (OPTION)
	21	102341	1 SEAL HOUSING, P5
	22	881079	1 SEAL, LIP
	23	881045	1 SETSCREW, 1/4-20 x 1"
▲2	24	882911	1 CHECK VALVE, 5 PSI, AFLAS
		101576	1 CHECK VALVE, 5 PSI, VITON (OPT)
▲3		102643	1 CHECK VALVE, 5 PSI, KALREZ (OPT)
	25	101088	1 3/8 x 1/4 FNPT TUBE ADAPT.

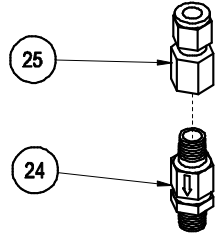

NO.	REVISION	DATE	BY	APVD	DRAWING	LEVELS
▲3	ADDED KALREZ OPT	06/25/09	SS		DRAWING	LEVELS
▲2	WAS #101671	03/15/04	SS		INJECTOR	10, 12, 14, 16, 18, 20, 24, 28, 30
▲1	WAS #101933	03/15/04	SS		FROM SER#	39-41, 89-93, 95-97, 99, 118, 119
					DATE	TO SER# DATE
					X	X X

TOLERANCES
ALL DIMENSIONS ARE IN INCHES UNLESS OTHERWISE SPECIFIED.

*TOL. DECIMALS:
.XXX= +/- .005
.XX= +/- .015
.X= +/- .030
FRAC.= +/- 1/16

*TOL. ANGLES:
+/- .5 DEGREES

*CONCENTRICITY:
.005 T. I. R.

REMOVE BURRS AND BREAK EDGES .005 MIN.

THIS PRINT IS CONFIDENTIAL AND IS THE PROPERTY OF HAMMONDS TECHNICAL SERVICES

THIS PRINT SHALL NOT BE LOANED, COPIED OR REPRODUCED IN WHOLE OR IN PART NOR SHALL THE CONTENTS BE RELEASED IN ANY MANNER TO ANYONE UNLESS WRITTEN PERMISSION IS OBTAINED FROM HAMMONDS TECHNICAL SERVICES.

HAMMONDS TECHNICAL SERVICES, INC.

SCALE	NTS	APPROVED	PART NUMBER	DRAWN BY	SS
DATE	10/07/99			REVISED	06/25/09
DRAWING TITLE		HAMMONDS 1P5 PUMP			
					DRAWING NUMBER
					3836

Hammonds Model PHC1 600-1 Portable Hand Cart Manual

ITEM	PART NO.	QTY.	DESCRIPTION
1	101014	1	POWER FRAME
2	102137	1	PLUNGER, P6
3	102138	1	FLUID END, P6
4	882949	8	LOCK WASHER, #10 INT. TOOTH
5	881317	4	SCREW, 10-32 x 2"
6	101842	1	CROSSHEAD GUIDE
7	101007	2	RETURN SPRING
8	101006	1	CROSSHEAD
9	101152	2	SLIDE BEARING
10	101005	1	STROKE ADJUSTMENT CAM
11	101003	1	CAM GUIDE
12	101001	1	STROKE ADJUSTMENT KNOB
13	101002	1	POWER FRAME COVER
14	101004	1	LOCK SCREW
15	101009	4	SCREW, 8-32 x 3/8"
16	881086	4	LOCKWASHER, #6
17	101010	4	SCREW, 6-32 x 3/8"
18	881089	4	SCREW, 10-32 x 3/4"
18A	881660	4	SCREW, 10-32 x 2 1/4" (OPTION)
19	102463	2	CHECK VALVE, AFLAS, STD.
	102464	2	CHECK VALVE, VITON (OPT)
20	101491	1	O-RING, AFLAS
	101417	1	O-RING, VITON (OPTION)
21	102139	1	SEAL HOUSING
22	881024	1	SEAL, LIP
23	881045	1	SETScrew, 1/4-20 x 1"
24	882911	1	CHECK VALVE, 5 PSI, AFLAS, STD.
	101576	1	CHECK VALVE, 5 PSI, VITON, (OPT)
25	101088	1	3/8 x 1/4 FNPT TUBE ADAPT.

	NEW CHECK VALVES	03/15/04	SS	
	WAS #102263	09/03/02	SS	
	REVISION			

DRAWING				LEVELS			VIEW
INJECTOR				10, 12, 14, 16, 18, 20, 24, 28, 30			7
FROM SER#				DATE	TO SER#	DATE	
X				X	X	X	

TOLERANCES	
ALL DIMENSIONS ARE IN INCHES UNLESS OTHERWISE SPECIFIED.	
*TOL. DECIMALS: .XXX= +/- .005 .XX= +/- .015 .X= +/- .030	*TOL. ANGLES: +/- .5 DEGREES *CONCENTRICITY: .005 T.I.R.

THIS PRINT IS
CONFIDENTIAL
AND IS THE PROPERTY OF
HAMMONDS TECHNICAL
SERVICES

THIS PRINT SHALL NOT BE LOANED, COPIED OR REPRODUCED IN WHOLE OR IN PART NOR SHALL THE CONTENTS BE REVEALED IN ANY MANNER TO ANYONE UNLESS WRITTEN PERMISSION IS OBTAINED FROM HAMMONDS TECHNICAL SERVICES.

HAMMONDS TECHNICAL SERVICES, INC.

SCALE	NTS	APPROVED BY:	DRAWN BY
DATE	09/22/92		SS
REVISION			03/15/04

HAMMONDS 1P6 PUMP

DRAWING NUMBER: 1687

Hammonds Model PHC1 600-1 Portable Hand Cart Manual

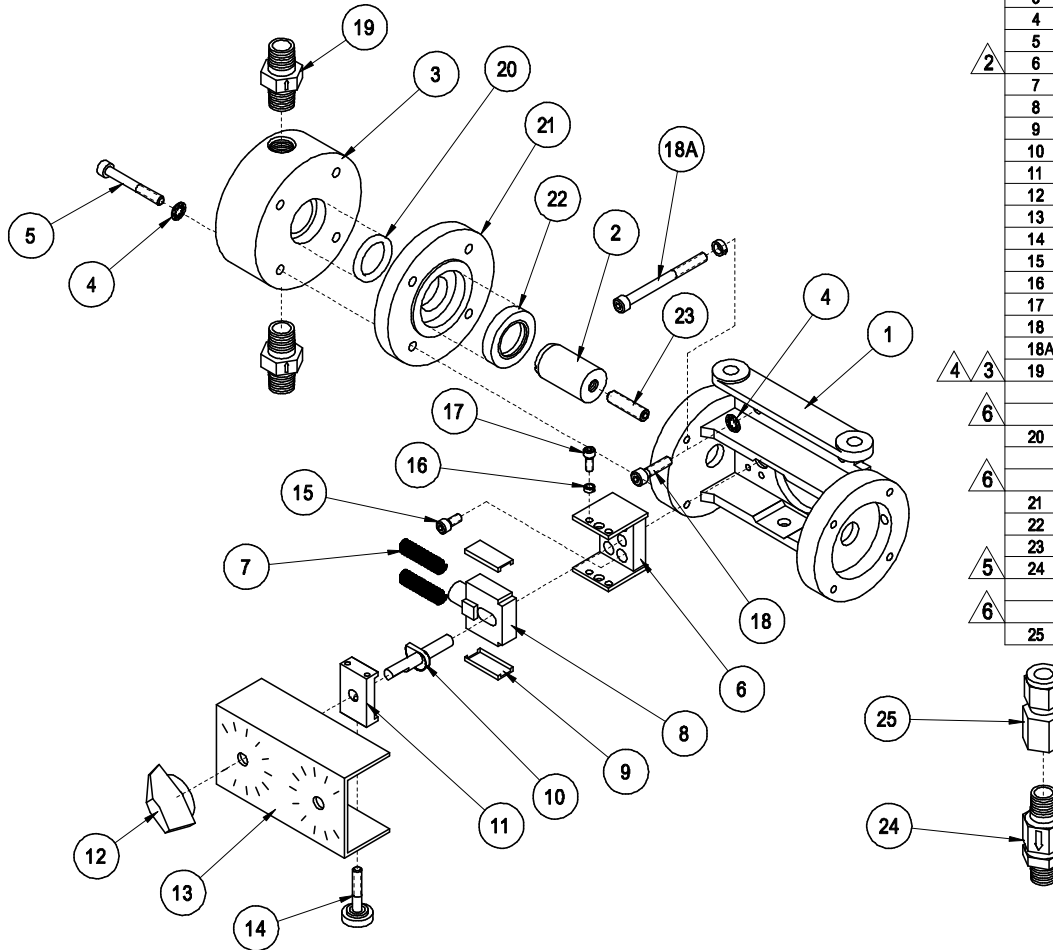

ITEM	PART NO.	QTY.	DESCRIPTION
1	101014	1	POWER FRAME
2	102192	1	PLUNGER, P7
3	102193	1	FLUID END, P7
4	882949	8	LOCK WASHER, #10 INT. TOOTH
5	881317	4	SCREW, 10-32 x 2"
6	101842	1	CROSSHEAD GUIDE
7	101007	2	RETURN SPRING
8	101006	1	CROSSHEAD
9	101152	2	SLIDE BEARING
10	101005	1	STROKE ADJUSTMENT CAM
11	101003	1	CAM GUIDE
12	101001	1	STROKE ADJUSTMENT KNOB
13	101002	1	POWER FRAME COVER
14	101004	1	LOCK SCREW
15	101009	4	SCREW, 8-32 x 3/8"
16	881086	4	LOCKWASHER, #6
17	101010	4	SCREW, 6-32 x 3/8"
18	881089	4	SCREW, 10-32 x 3/4"
18A	881660	4	SCREW, 10-32 x 2 1/4" (OPTION)
19	102463	2	CHECK VALVE, AFLAS
	102464	2	CHECK VALVE, VITON (OPTION)
	102642	2	CHECK VALVE, KALREZ (OPTION)
20	101490	1	O-RING, AFLAS
	101226	1	O-RING, VITON (OPTION)
	101754	1	O-RING, KALREZ (OPTION)
21	102194	1	SEAL HOUSING
22	881765	1	SEAL, LIP
23	881045	1	SETScrew, 1/4-20 x 1"
24	882911	1	CHECK VALVE, 5 PSI, AFLAS, STD.
	101576	1	CHECK VALVE, 5 PSI, VITON, (OPT)
	102643	1	CHECK VALVE, 5 PSI, KALREZ, (OPT)
25	101088	1	3/8 x 1/4 FNPT TUBE ADAPT.

6	ADDED PART NOS.	01/21/14	SS
5	WAS #101671	03/15/04	SS
4	WAS #101933	03/15/04	SS
3	WAS #102263	09/03/02	SS
2	WAS #101008	08/99	SS
1	ADDED INJ CHK VLV	01/06/98	SS
NO.	REVISION	DATE	BY
			X

DRAWING	LEVELS	VIEW
INJECTOR	10,12,14,16,18,20,24,28,30	1
FROM SER#	DATE	TO SER#
		DATE
X	X	X

TOLERANCES
ALL DIMENSIONS ARE IN INCHES
UNLESS OTHERWISE SPECIFIED.

*TOL. DECIMALS:
.XXX = +/- .005
.XX = +/- .015
.X = +/- .030
FRAC. = +/- 1/16

*TOL. ANGLES:
+/- .5 DEGREES

*CONCENTRICITY:
.005 T. I. R.

REMOVE BURRS AND BREAK EDGES .005 MIN.

THIS PRINT IS
CONFIDENTIAL

AND IS THE PROPERTY OF
HAMMONDS TECHNICAL
SERVICES

THIS PRINT SHALL NOT BE USED, COPIED
OR REPRODUCED IN WHOLE OR IN PART
WITHOUT THE EXPRESS WRITTEN
PERMISSION OF HAMMONDS TECHNICAL SERVICES.

HAMMONDS TECHNICAL SERVICES, INC.

SCALE: NTS APPROVED: PART NUMBER: DRAWN BY: SS

DATE: 05/11/93 REVISED: 01/21/14

DRAWING TITLE: HAMMONDS 1P7 PUMP ASSEMBLY
DRAWING NUMBER: 1911

Hammonds Model PHC1 600-1 Portable Hand Cart Manual

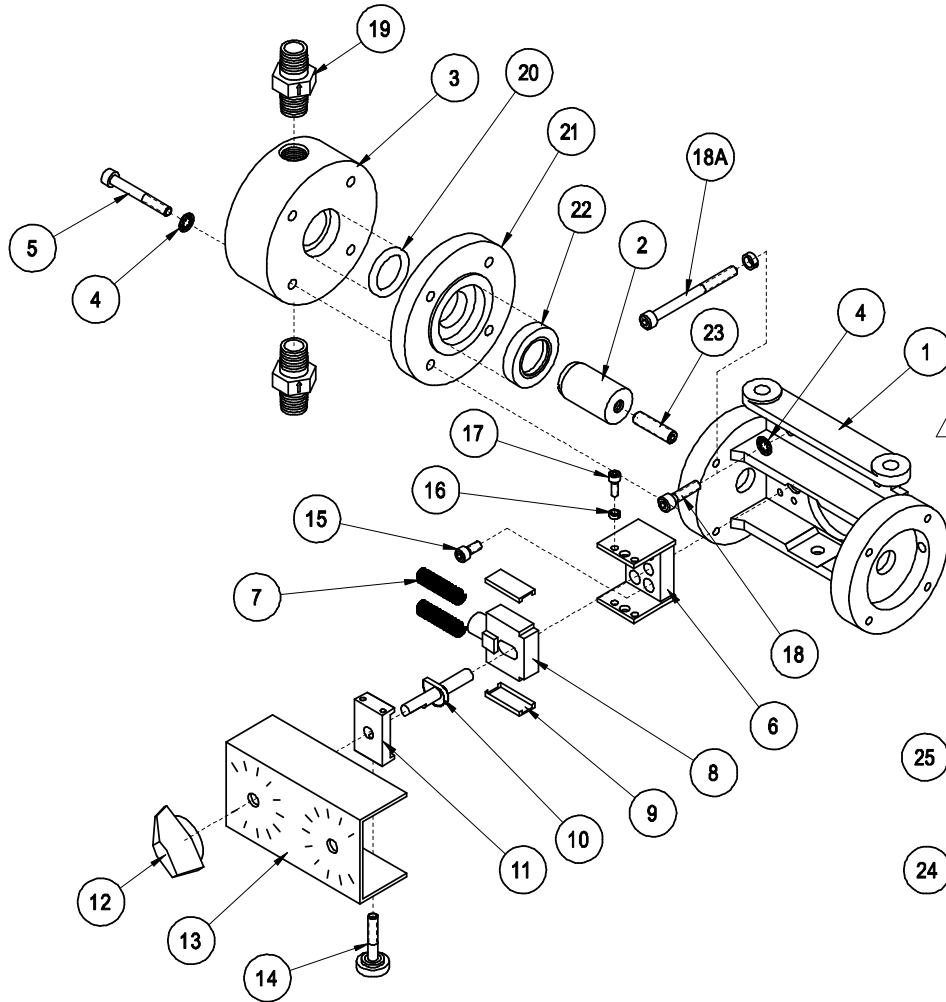

ITEM	PART NO.	QTY.	DESCRIPTION
1	101014	1	POWER FRAME
2	102224	1	PLUNGER, P10
3	102225	1	FLUID END, P10
4	882949	8	LOCK WASHER, #10 INT. TOOTH
5	881317	4	SCREW, 10-32 x 2"
6	101842	1	CROSSHEAD GUIDE
7	101007	2	RETURN SPRING
8	101006	1	CROSSHEAD
9	101152	2	SLIDE BEARING
10	101005	1	STROKE ADJUSTMENT CAM
11	101003	1	CAM GUIDE
12	101001	1	STROKE ADJUSTMENT KNOB
13	101002	1	POWER FRAME COVER
14	101004	1	LOCK SCREW
15	101009	4	SCREW, 8-32 x 3/8"
16	881086	4	LOCKWASHER, #6
17	101010	4	SCREW, 6-32 x 3/8"
18	881089	4	SCREW, 10-32 x 3/4"
18A	881660	4	SCREW, 10-32 x 2 1/4" (OPTION)
19	102463	2	CHECK VALVE, AFLAS, STD.
	102464	2	CHECK VALVE, VITON, (OPTION)
20	101537	1	O-RING, AFLAS
	101839	1	O-RING, VITON (OPTION)
	101883	1	O-RING, EPDM (OPTION)
21	102226	1	SEAL HOUSING
22	881908	1	SEAL, LIP
23	881045	1	SETSCREW, 1/4-20 x 1"
24	882911	1	CHECK VALVE, 5 PSI, AFLAS, STD.
	101576	1	CHECK VALVE, 5 PSI, VITON (OPT)
25	101088	1	3/8 x 1/4 FNPT TUBE ADAPT.

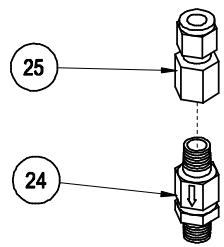

△	WAS #101671	03/15/04	SS	X					
△	WAS #101933	03/15/04	SS	X					
△	WAS #102263	09/03/02	SS	X					
△	WAS #101008	08/99	SS	X					
NO.	REVISION	DATE	BY	APPVD					

DRAWING	LEVELS		
INJECTOR	10, 12, 14, 16, 18, 20, 24, 28, 30		
FROM SER#	DATE	TO SER#	DATE
X	X	X	X

TOLERANCES
ALL DIMENSIONS ARE IN INCHES UNLESS OTHERWISE SPECIFIED.

*TOL. DECIMALS:
.XXX= +/- .005
.XX= +/- .015
.X= +/- .030
FRAC.= +/- 1/16

*TOL. ANGLES:
+/- .5 DEGREES

*CONCENTRICITY:
.005 T.I.R.

REMOVE BURRS AND BREAK EDGES .005 MIN.

THIS PRINT IS CONFIDENTIAL AND IS THE PROPERTY OF HAMMONDS TECHNICAL SERVICES

THIS PRINT SHALL NOT BE LOANED, COPIED OR REPRODUCED IN WHOLE OR IN PART NOR SHALL THE CONTENTS BE REVEALED IN ANY MANNER TO ANYONE UNLESS WRITTEN PERMISSION IS OBTAINED FROM HAMMONDS TECHNICAL SERVICES.

HAMMONDS TECHNICAL SERVICES, INC.			
SCALE	NTS	APPROVED	PART NUMBER
DATE	08/23/93		
DRAWING TITLE	HAMMONDS 1P10 PUMP		
		DRAWN BY	SS
		REVISED	03/15/04
		DRAWING NUMBER	2668

Hammonds Model PHC1 600-1 Portable Hand Cart Manual

ITEM	PART NO.	QTY.	DESCRIPTION
1		1	5SF ASSY (SEE DWG#4229)
2	101057	1	1/4" x 1/4" TUBE ADAPTER
3	101059-02	1	1/4" SIPHON VENT TUBE
4	881347	1	VENT HOSE
5	881142	1	DESICCANT DRYER
6	101069	2	1/4" x CL PIPE NIPPLE
7	102735	2	1/4" ON/OFF VALVE
8	883894	1	QD STEM, 1/4" MNPT, BUNA-N (OPT)
	883388	1	QD STEM, 1/4" MNPT, NEOPRENE (OPT)
	882998	1	QD STEM, 1/4" MNPT, VITON (OPT)
9	883864	1	QD BODY, 1/4" FNPT, BUNA-N (OPT)
	883387	1	QD BODY, 1/4" FNPT, NEOPRENE (OPT)
	882997	1	QD BODY, 1/4" FNPT, VITON (OPT)
10	885261	1	QD BODY PROTECTOR
11	885262	1	QD STEM PROTECTOR
12	884637	1	1/4" MNPT X 40" SS BRAIDED HOSE
14	101021	1	1/4" 90 ELBOW
15	102591	1	1/4" 3-WAY VALVE
16	101034	1	3/8" x 1/4" TUBE ADAPTER
17	881139-05	1	3/8" BLEED TUBE
18	101068	1	3/8" x 1/4" EL TUBE ADAPT

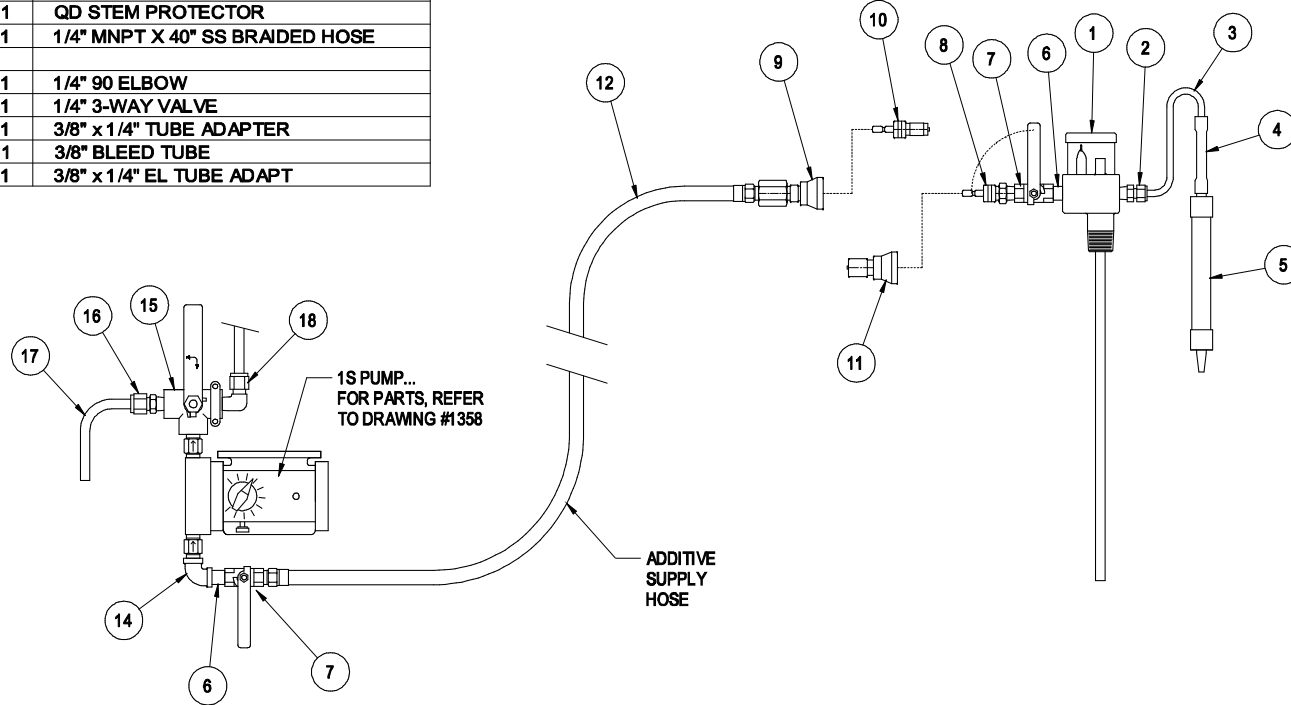

TOLERANCES ALL DIMENSIONS ARE IN INCHES UNLESS OTHERWISE SPECIFIED.		*TOL. DECIMALS: .XXX= +/- .005 .XX= +/- .015 .X= +/- .030 FRAC.= +/- 1/16		*TOL. ANGLES: +/- .5 DEGREES *CONCENTRICITY: .005 T.I.R.		*REMOVE BURRS AND BREAK EDGES .005 MIN.		THIS PRINT IS CONFIDENTIAL AND IS THE PROPERTY OF HAMMONDS TECHNICAL SERVICES		HAMMONDS TECHNICAL SERVICES, INC.	
								SCALE: NTS	APPROVED PART NUMBER: .	DRAWN BY: SS	
DATE: 11/08/17		REVISED: .		DRAWING TITLE: 5SF ASSY. FOR PHC-CART		DRAWING NUMBER: 7676					

NO.	REVISION	DATE	BY	APPVD	FROM SER#	DATE	TO SER#	DATE
		11/06/17	SS	X	X	X	X	X

Hammonds Model PHC1 600-1 Portable Hand Cart Manual

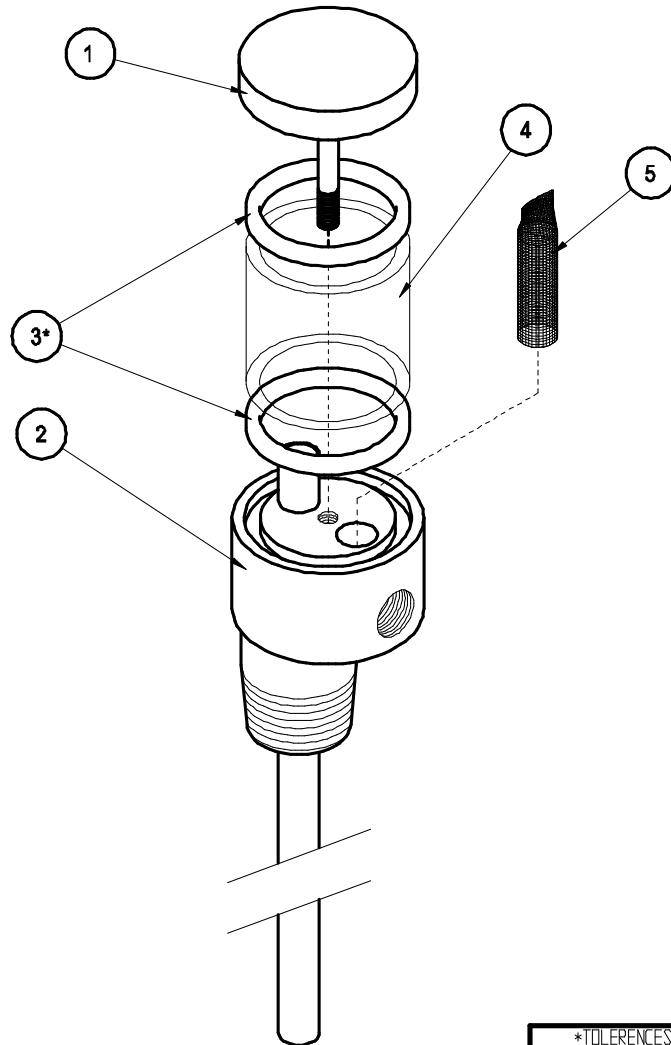

ITEM	PART NO.	QTY.	DESCRIPTION
1	152074	1	CAP, ASS'Y.
2	152084	1	BODY, ASS'Y. 5SF
3	151002	2	O-RING, BUNA
4	151001	1	GLASS
5	152002	1	FILTER ELEMENT
* 3	151007	2	O-RING, VITON (OPT)
* 3	151027	2	O-RING, NEOPRENE (OPT)

* NOTE: THIS COMPONENT IS PART
OF VARIOUS ASSEMBLIES

TOLERANCES ALL DIMENSIONS ARE IN INCHES UNLESS OTHERWISE SPECIFIED.				THIS PRINT IS CONFIDENTIAL AND IS THE PROPERTY OF HAMMONDS TECHNICAL SERVICES				HAMMONDS TECHNICAL SERVICES, INC.							
DRAWING 0159		LEVELS 7, B		VIEW 1		SCALE NPS		APPROVED BY: .		DRAWN BY SS					
DATE 10/11/01		BY SS		APPVD X		DATE 10/11/01		REVISION		DRAWING TITLE 5SF SIGHT FLOW INDICATOR					
NO.		REVISION		DATE		BY		APPVD		DRAWING NUMBER 4229					
FROM SER#				DATE				TO SER#				DATE			
X				X				X				X			
SURFACE FINISH 125				REMOVE ELBORS AND BREAK EDGES				TOL. DECIMALS: .XXX= +/- .005 .XX= +/- .015 .X= +/- .030 FRAC.= +/- 1/16				TOL. ANGLES: +/- .5 DEGREES			
								*CONCENTRICITY: .005 T.I.R.				THIS PRINT SHALL NOT BE USED, COPIED OR REPRODUCED IN WHOLE OR IN PART OR SHALL THE CONTENTS BE RELEASED IN ANY MANNER TO ANYONE UNLESS WRITTEN PERMISSION IS OBTAINED FROM HAMMONDS TECHNICAL SERVICES.			
								* BASE 5SF							