

OPERATING INSTRUCTIONS AND MAINTENANCE GUIDE

HAMMONDS TPI-4T-4A-1 FUEL ADDITIVE INJECTOR

**HAMMONDS SERIAL NUMBERS:
7500 - Present**

Manufactured by



HAMMONDS TECHNICAL SERVICES, INC.

6807 West Little York Rd.

Houston, Texas 77040

Ph: 281-999-2900

Fax: 713-896-9419

www.hammondscos.com

Revised February 2025

TABLE OF CONTENTS

Specifications	2
Typical System Layout	3
How The System Works	4
Illustration of TPI-4T-4A-1 System	5
Illustration of Bare 800 Injector	6
Illustration of TPI-4T-4A-1 Control Panel	7
Description of Major Components	8 - 10
Preparation for Start-up	10
Connecting the FSII Drum	11
Priming the System	12 - 13
Calibrating The System	14 - 15
Normal Operation	16
Shutdown and Preparation for Storage	17
Trouble Shooting the System	18 - 23
Preventative Maintenance	24 - 26
Assembly and Disassembly Instructions	27 – 37
Major Internal Pump Service	38 – 40
CI/SDA Pump Plunger and Seal Service	40 – 41
Drawings and Parts lists in order of appearance:	
4832A TPI-4T-4A-1 General System layout	42
4932 Control Panel layout (front view)	43
4932A Control Panel layout (rear view)	44
4933 Skid Sub-Assembly	45
4935 Injector Sub-Assembly	46
Tool Kit parts list	47
Control Panel Assembly parts list	48-50
800ER repair kit parts list	51
2L Pump repair kit parts list	52
1P7-1P7 Pump repair kit parts list	53
HVSFI and SFI repair kit parts list	54
FSII Sample Test Kit parts list	55
	56
3990A 6 Gallon Tank assembly	57
4934 4” Sample Probe assembly	58
4864 Model 800ER Driver (aluminum) cross section view	59
1694 Hammonds 3:1 Gear Reducer cross section view	60
5547 Hammonds 2L (1L-1L) Pump HD exploded view	61
1461-1 ‘L’ Diaphragm replacement instructions	62
5655 Hammonds 2P7 (1P7-1P7) Pump HD exploded view	63
HD pump internal parts exploded view	64
0159 Standard Sight Flow Indicator (SFI)	65
1349 Hi Volume Sight Flow Indicator (HVSFI)	66
TYPICAL SYSTEM LAYOUT	67
6916 FLUID SCHEMATIC	68

SYSTEM SPECIFICATIONS

Model Number: **TPI-4T-4A-1**

Description: Portable, multi-additive injector

Size: **40" wide X 48" long X 40" high**

Weight: **920 pounds**

Product Connections: 4" Cam-lock connections

Additive Connections: CI and SDA: 1/4" braided stainless Teflon® hose w/JIC fitting
FSII: 3/4" braided stainless Teflon® hose w/JIC fitting

Fuel Flow Operating Range: **150 - 700 GPM**

Injection Ratio Capacity: CI and SDA: 40 PPM
FSII: 2100 PPM

Duty Cycle: Continuous

Elastomers:

- * Additive Injection Diaphragms are Teflon®
- * Additive Injection Plunger Seals are Aflas®
- * Mechanical Seal: Ceramic on Carbon
- * O-rings, static seals – Nitrile and Viton®
- * Injection Check Valves - Aflas®

Materials of Construction:

- Fluid Motor: Anodized aluminum
- Motor Rotor: Anodized aluminum
- Motor Shaft: Stainless Steel
- Injectors: All wetted parts stainless steel
- Additive Manifold: All wetted parts stainless steel

Operating Environment: Out of Doors

Operating Temperature Range: -25° F to +120° F

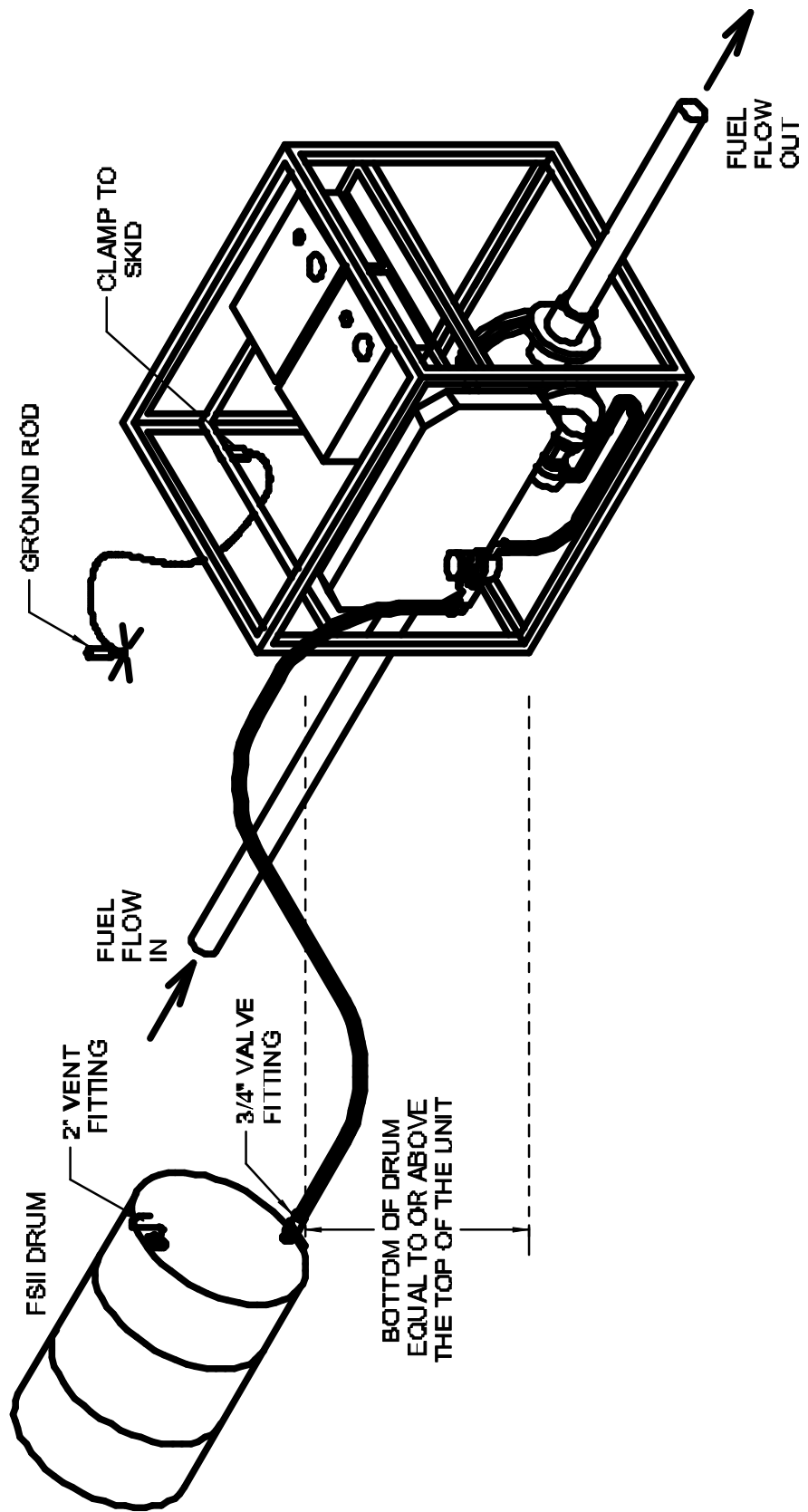

TYPICAL SYSTEM LAYOUT

HOW THE SYSTEM WORKS

The TPI-4T-4A-1 is a fluid powered, multi-additive injection system. The TPI-4T-4A-1 provides proportionate-to-flow additive injection by borrowing enough energy in the flowing jet fuel line to turn the Fluid Motor. As fuel flow increases or decreases in volume, the Fluid Motor responds by turning faster or slower.

Since the all three injectors are directly linked to the Fluid Motor, they also increase and decrease in speed with the flow of fuel as it passes through the system and are therefore *proportionate-to flow*. After the injectors are calibrated at a given fuel flow rate, they remain at the same injection ratio throughout the flow range of the system. For example, if the injectors are calibrated to deliver a certain injection ratio at 300 gpm, the system will remain in calibration at any flow rate from 150 - 700 gpm.

The TPI-4T-4A-1 is both powered and controlled by the flow of fuel passing through the Fluid Motor. No external power or a meter is required for operation. The system is “passive”. When fuel flow begins, injection begins. When flow slows or stops, injection slows or stops proportionately, with no action required from the operator. All that is required is fuel passing through the system and a supply of additives.

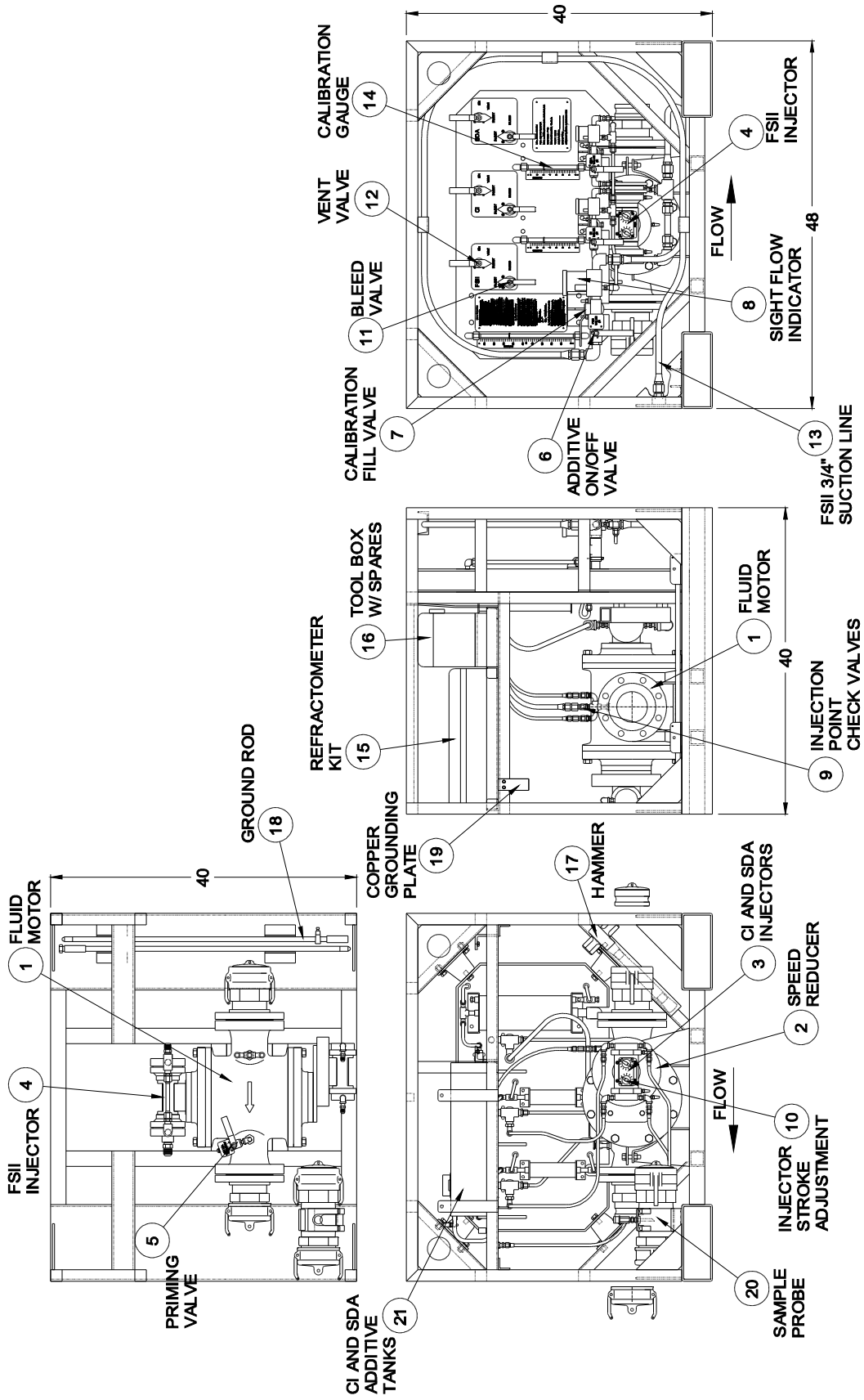

HAMMONDS MODEL TPI-4T-4A-1

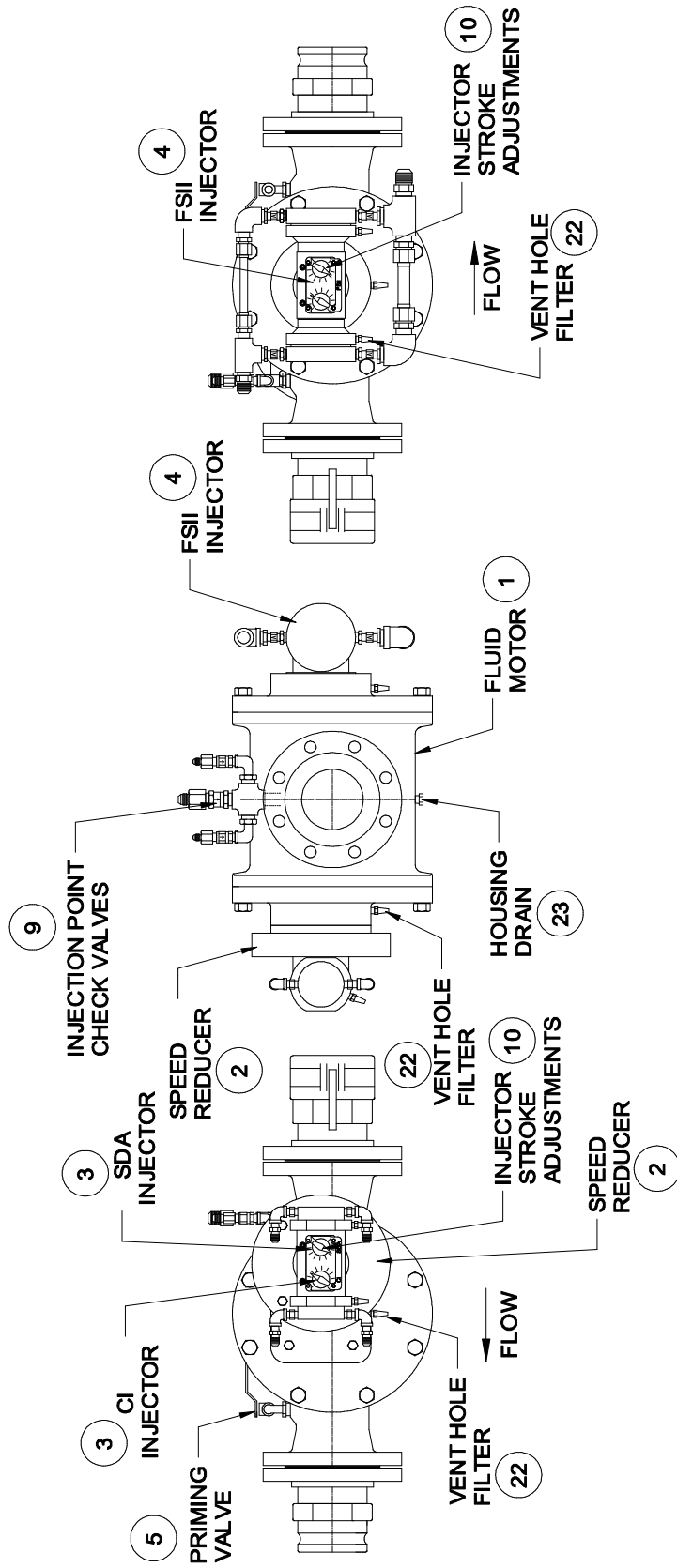

BARE MODEL 800 INJECTOR

TPI-4T-4A-1 CONTOL PANEL

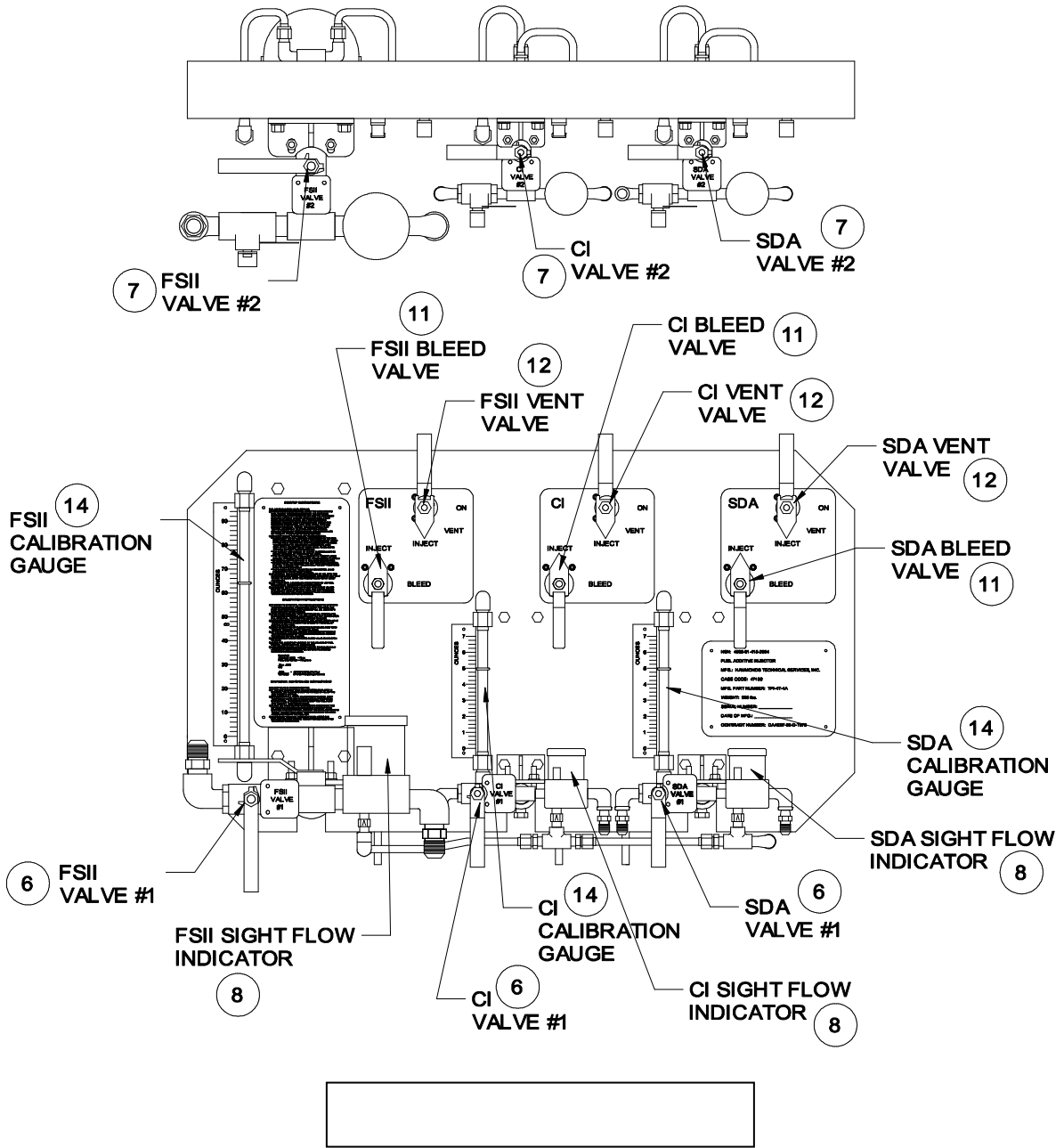

DESCRIPTION OF MAJOR COMPONENTS

Refer to 3 previous pages

1. **FLUID MOTOR:** The Fluid Motor borrows just enough energy from the flowing fuel to power the three additive injectors.
2. **SPEED REDUCER:** Since the CI and SDA additives are injected at a very low ratio, these two injectors operate at a much slower speed than the FSII injector. The Fluid Motor speed is reduced by this reducer at a 3:1 ratio, making it possible to calibrate the CI and SDA injectors at a very low ratio.
3. **CI AND SDA INJECTORS:** These injectors share a common power frame with one fluid end dedicated to each additive. Although mounted together in the same frame, each operates completely independent of the other. Both pumps include a stroke adjustment and each a separate additive source. Either injector may be turned off by closing the additive valve #1 or adjusting the stroke adjustment to zero.
4. **FSII INJECTOR:** Since FSII is injected at a high ratio (1000 - 2000 PPM or 1 - 2 gallons per 1000 gallons of fuel) a high capacity injector is required. The FSII injector uses two large pump heads that are connected together for combined output. Although each pump head has a separate stroke adjustment and can be adjusted independently, both are usually set about the same to keep the system balanced. In an emergency, one of the heads operating at near full capacity could inject the required ratio of FSII with the other head stroke adjustment set to zero.
5. **PRIMING VALVE:** Since systems arrive empty, and are often stored for long periods of time, a means to prime the system initially and to purge or clean the system out prior to storage is provided. With fuel lines connected and flowing, the Priming valve takes fuel from the product line, under pressure and is used to feed all three injectors. First, close all of the #1 valves, set Bleed and vent valves to inject, open the Priming valve for at least 30 seconds. The manifold and pumps are filled almost instantly. Prior to storage, the system can be purged of additive with the same procedure. CI and SDA are particularly bad about drying in the pumps and lines, forming a thick, sticky residue that is very difficult to remove the next time the system is used. If the system is not purged before storage, it would likely be necessary to completely disassemble the pumps and clean them prior to the next use.
6. **ADDITIVE ON/OFF VALVE:** Labeled #1 valve for each additive. It is used to interrupt the supply of additive between the additive tank and the injector. It can be turned off at any time without harm to the pump. The units are transported and stored with all three of these valves in the closed position.
7. **CALIBRATION FILL VALVE:** Labeled #2 valve for each additive. It is used to fill the calibration gauge to be able to field calibrate the injectors.
8. **SIGHT FLOW INDICATOR:** The Sight Flow Indicator serves a three-fold purpose. First, it allows the operator to monitor the presence of additive in the system. Second, it allows the operator to observe the exact amount of additive being injected into the system. Unlike some flow indicators that move wheels or rattle balls, the Sight Flow Indicator shoots the additive up out of the tube as it is drawn into the injector. Since every drop of additive that the injector pumps must pass through this indicator, this device provides proof positive that additive is moving into the system. The operator can see the additive as it is being drawn into the pumps. Finally, the Sight Flow Indicator has a screen filter. And since the walls of the

indicator are glass, it is possible to observe the condition of the filter during operation and perform preventative maintenance when required.

9. INJECTION POINT CHECK VALVES: These valves are special valves with soft seat elastomers that prevent jet fuel from migrating back into the injectors while allowing additive to be injected into the fuel. There is a separate check valve for each additive (total of three).
10. INJECTOR STROKE ADJUSTMENTS: The stroke adjustments allow the length of stroke of each pump fluid end to be adjustable throughout its range.
11. BLEED VALVE: These are three-way valves and are provided for each additive. The valve has two positions: *inject and bleed*.
12. VENT VALVE: These are two-way valves and are provided for each additive. The valve has two positions: inject (off) and on (open).
13. FSII ¾" SUCTION LINE: Its storage place is on a JIC fitting mounted on the skid. The swivel connection is only finger tight. Loosen and remove this end only as the other end is tightly connected to the FSII Sight Flow Indicator. Be careful not to get dirt in the end of this hose.
14. CALIBRATION GAUGE: One complete gauge is provided for each additive. It includes a translucent tube to see the level of liquid and a scale for volume measurement that runs parallel to the tube. The tube is directly connected to a reservoir of additive located behind the Control Panel. These reservoirs have enough capacity to make a typical calibration run.
15. REFRACTOMETER KIT: A complete kit for testing the FSII content of the fuel. The kit is packaged into a rugged case. It is secured to its storage location on the skid by 2 bungee stretch cords.
16. TOOL BOX W/SPARES: The toolbox contains the necessary tools needed to perform preventative maintenance and repairs on the system. Also, contained in the toolbox is a 2-year supply of spares. The spares are divided into 4 packages: 800ER Driver repair kit (Fluid Motor), 1P7-1P7 SS pump kit (CI & SDA), 2L SS pump kit (FSII), and HVSFI & 2 SFI repair kit (Sight Flow Indicators). The fittings to connect the FSII drum are contained in the toolbox along with a quick reference illustration of a typical system layout.
17. HAMMER: The hammer is provided to drive the ground rods into the soil. The hammer is secured with a single removable pin in its storage place on the skid.
18. GROUND ROD: The system must be properly grounded before each use. See "Grounding the System".
19. COPPER GROUNDING PLATE: The copper grounding plate is provided to properly ground the system. The clamp on the ground rod is to be securely clamped to this plate.
20. SAMPLE PROBE: The system includes a 4" adapter with a sampling probe that can be used on either the fuel inlet or outlet of the injector.
21. CI AND SDA ADDITIVE TANKS: The additive tanks for CI & SDA are contained within the skid for your convenience and they are positioned for proper flooded suction to the injectors. The tanks are already connected to their proper locations. It is not necessary to neither disconnect the lines nor remove these tanks unless you are performing major repair service. Each tank can be filled from the top. Each tank has a filler with a stainless steel basket for straining the additive. There is a liquid level gauge provided on the top of each tank.
22. VENT HOLE FILTER: A vent hole is provided on both sides of the Fluid Motor to indicate when there is a mechanical seal leaking jet fuel. A vent hole is also provided on each fluid end of both injector pumps to indicate leaking additive when a diaphragm or plunger seal has

failed. A filter is installed in each of these vent holes. This filter is a sintered material, which allows the venting to occur, and it prevents dirt from migrating inward.

23. HOUSING DRAIN: A ¼” pipe plug is provided in the bottom, center of the Fluid Motor housing to drain any remaining jet fuel when servicing is needed.

PREPARATION FOR START-UP

GROUNDING THE SYSTEM

Place the unit on level ground. The unit must be grounded before use. Remove the ground rods supplied with the system. First, use the ground rod without the wire. Make certain



the driving stud is threaded into the coupling on top of this rod. **CAUTION!** Have eye protection on! Use the 4lb hammer supplied to drive the rod into the ground, point first, near the unit, until only the coupling is exposed. Remove the driving stud and thread the remaining ground rod, with wire at the top, into the exposed coupling of the first rod. Thread the driving stud into the top and drive it to within 4” of the ground. Connect the clamp to the copper grounding plate on the unit. The system is now grounded.

GROUNDING THE SYSTEM

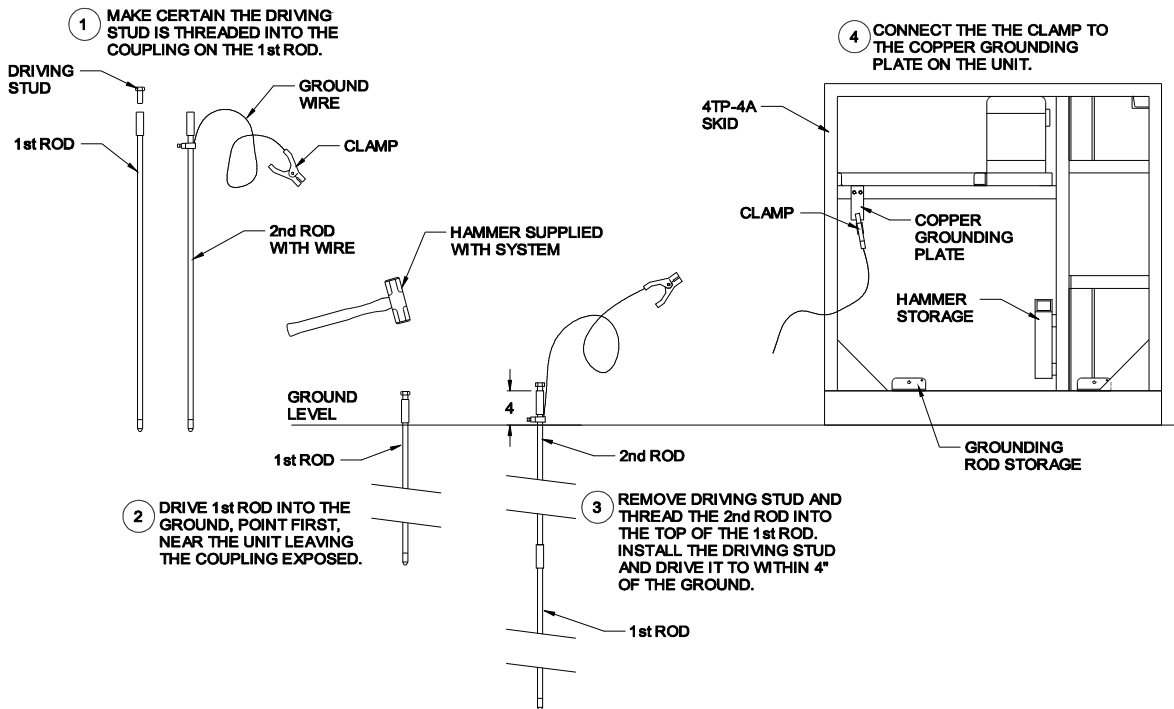

CONNECTING THE FSII DRUM

Disconnect the 3/4" FSII suction line from its storage point on the skid. Remove only the swivel end that is mounted to the inside of the frame, it is finger tight. The hose end has a swivel fitting to make connection easy.

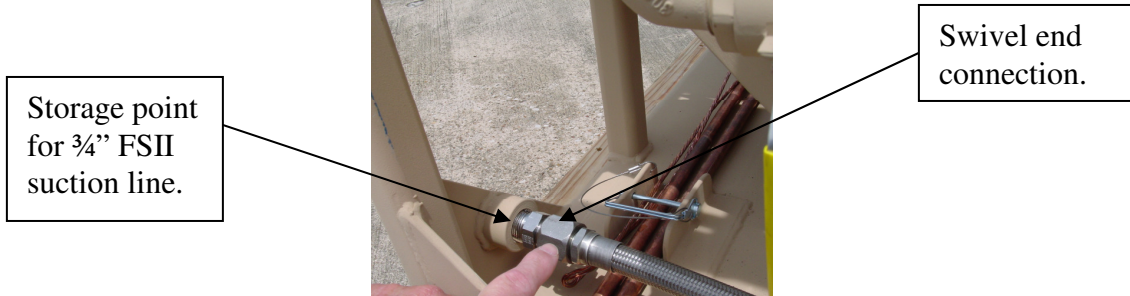

The other end is connected to valve #1 and should remain tightly connected. With the FSII drum upright remove the bung plugs and install the supplied 3/4" valve fitting and 2" vent fitting into the appropriate bungs on the FSII drum. Be certain to apply thread sealant tape to the pipe threads before each installation.

The FSII drum must be positioned horizontally, with the vent at the top and the bottom of the drum equal to or slightly above the top of the unit. Connect the swivel fitting on the supply hose to the valve fitting on the drum. If this positioning is not followed, the system may not perform to its optimum.

The suction line leading to the system must be below the level of additive in the drum. The FSII injector will pull suction to the unit. Make certain the drum's vent is always open and not plugged. Be careful not to get dirt in the hose connections. Make certain the connections are tight and leak free.



CAUTION: the slightest air leak will prevent the system from working properly. The CI and SDA additive tanks on the system remain connected. Make certain these tanks are at least 1/4

CONNECTING THE FSII DRUM

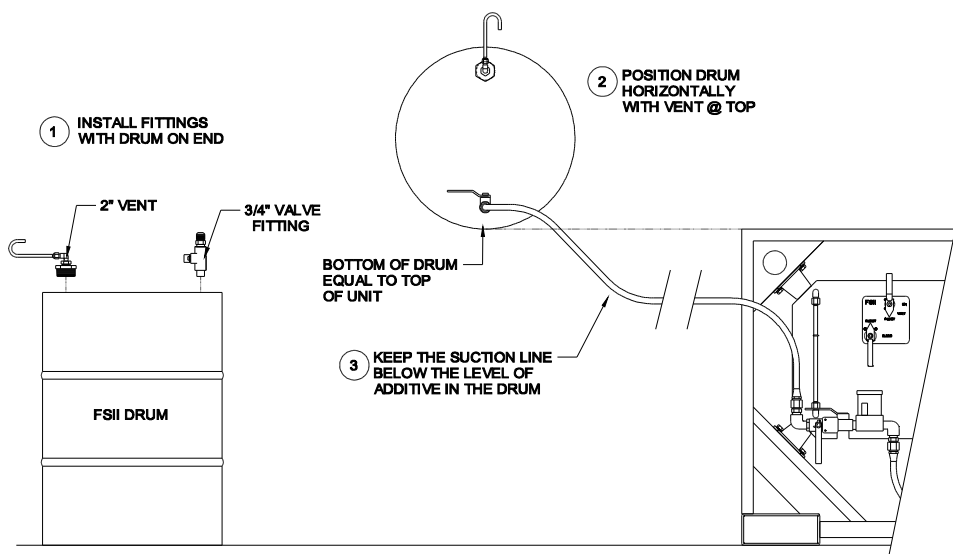

full.

PRIMING THE SYSTEM

It is necessary to fill the additive lines, the Sight Flow Indicator and the pump fluid ends with additive prior to operation. Although the injectors would eventually prime themselves, the process would take time and require running a large amount of product through the system and the pumps would be required to purge the air from the system.

After fuel has been connected to the system and pressurized and the FSII drum has been connected as described above, you are ready to prime the system. Locate the Priming valve on the injector housing. Close valve #1 on all additives and set the Bleed and Vent valves to inject. Open the Priming valve for at least 30 seconds. Let it run until a clear (air-free) stream of jet fuel is observed in the sight flow indicators. Now close the Priming valve and open valve #1 for each additive. Let it run until the additives have purged the jet fuel from the sight flow indicators. The system is ready for operation.

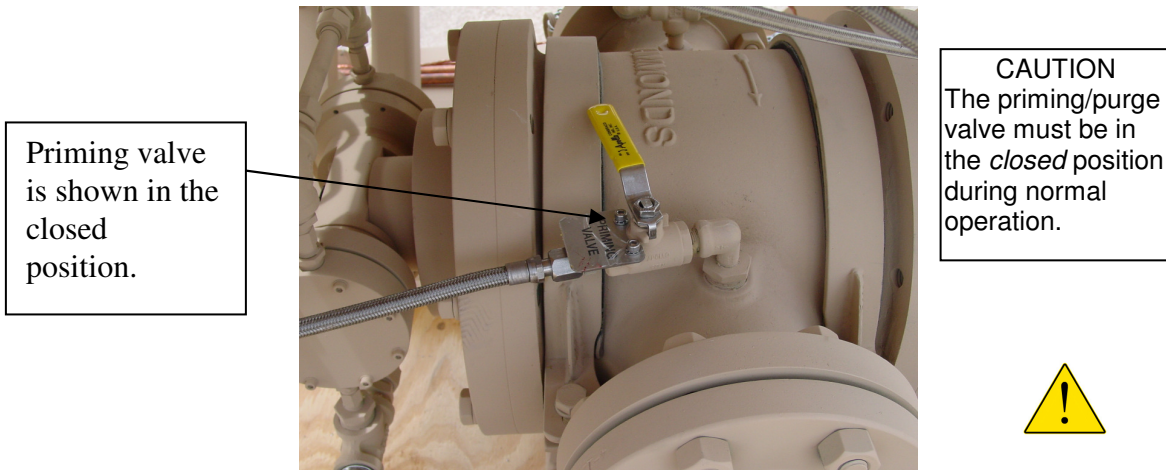

The priming/purge system is connected to each of the additive injectors through the bottom of the Sight Flow Indicators. To prevent additive from migrating into the priming manifold, a check valve is installed at each Sight Flow Indicator. In the unlikely event that one of these valves would leak, the additive delivery system would not be affected since the main Priming valve is always off during normal injection.

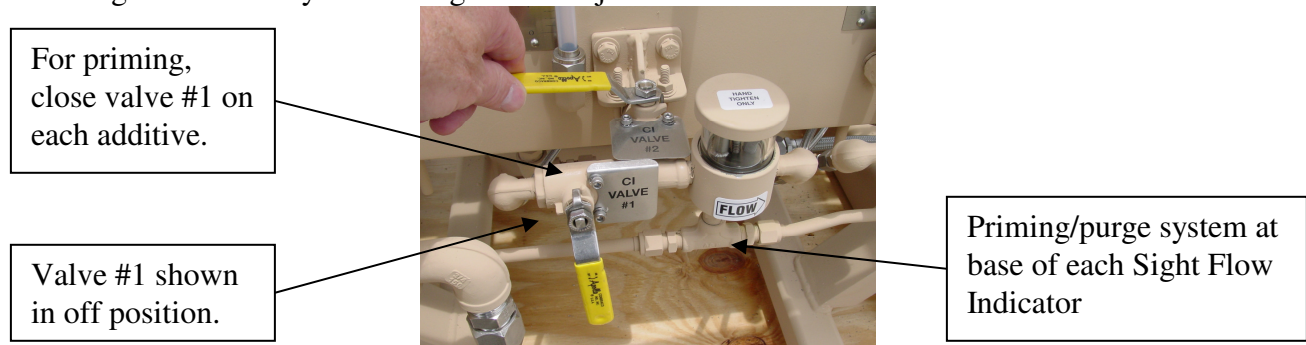

After the pump heads have been fully primed, they will remain primed even when the system is stopped intermittently

THE IMPORTANCE OF PRIMING THE SYSTEM

All fluid pumps perform well only if supplied with adequate fluid. Air is the single greatest enemy of any pump. If the system is not properly supplied with a solid, air free supply of fluid, the pump can become air locked and either perform poorly or not at all.

Remember, the CI and SDA pumps operate at very low output (about 20 PPM). The pumps have a maximum stroke length of only 3/16" and discharge only drops of additive with each stroke. If air is in the system, the pumps cannot perform properly and they are even less able to pull suction from a distance. *A COMPLETE, AIR FREE PRIME TO THE INJECTORS WILL GUARANTEE THE BEST POSSIBLE PERFORMANCE.*

IMPORTANT RULES FOR CONNECTING ADDITIVE SUPPLIES

- Make sure tank/drum is level with or above the injector inlet.
- Tube fittings must match those on the system.
- All connections must be airtight. Remember, there is a vacuum on the suction side of each pump. The connection can be leaking without visible additive leaks. Vacuum leaks will cause erratic operation or failure.

Watch your additive levels and do not allow the system to run dry. If the system runs out of additive, re-priming will be necessary.

CALIBRATING THE SYSTEM

1. Place the unit on level ground
2. Connect the additive supplies to the system (see “*Connecting the FSII Drum*”)
3. Be sure injectors are primed (see “*Priming The System*”)
4. Check the vents on all additive tanks/drum and be sure they are open.
5. Select an additive. Valve #1 must be open and the Bleed and Vent valves must be set to inject.

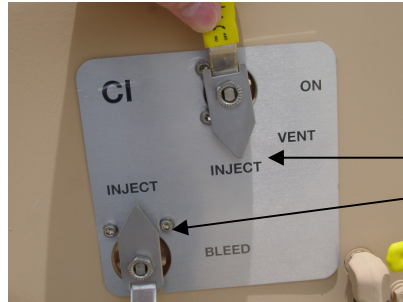

Bleed and Vent valves set to inject

6. Open valve #2. Turn Vent valve on. This will fill the calibration gauge tube. Fill gauge near the top. Do not over fill. Once full, turn Vent valve back to inject.

To fill calibration gauge

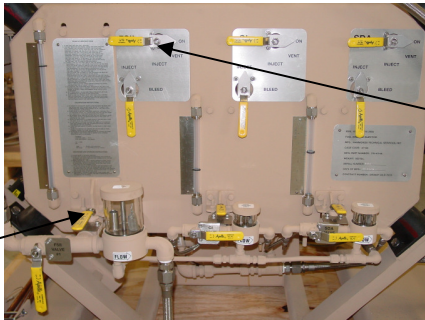

Turn Vent valve on until full. Then turn back to inject

Open valve #2

7. Determine what amount of fuel will be delivered. Move the O-ring on the calibration gauge to the level of additive in the tube.

Move O-ring to level of additive



- Begin calibration by closing valve #1. Now turn the Vent valve on. Start the fuel flow.

Valve #1 shown closed.

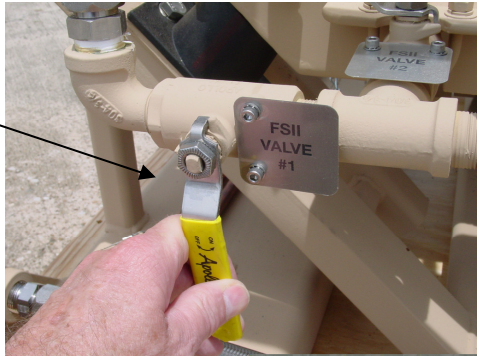

- At the end of the run, record the amount of additive that was drawn from the calibration gauge. Record the amount of fuel delivered.
- Turn the Vent valve to inject, close valve #2 and open valve #1.
- Divide the amount of additive by the volume of fuel delivered, giving you PPM. See example.
- Increase or decrease percentage of stroke on pump and repeat test from step #6 above until desired injection ratio is obtained. Make certain to lock the adjustments securely with the setscrews located below each of the stroke adjustment knobs.

Stroke adjustments

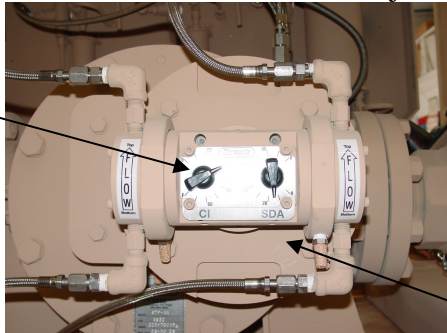

Setscrew located below adjustment knob.

- Repeat for the other two additives.

EXAMPLE

Additive used = 70 oz
 Fuel delivered = 440 gallons

$$\frac{70}{440} = .1590$$

$$\frac{.1590}{128 \text{ oz/gal}} = .001242 \text{ (1242 millionths) or 1242 PPM (parts per million)}$$

NORMAL OPERATION

Following initial start-up and calibration, the system requires very little attention other than making certain that additive tank levels are maintained. Operators will quickly become accustomed to the performance of the system by observing the Sight Flow Indicators. On-spec injection will cause a certain response in the indicators, and with some practice, operators will be able to observe the system and qualify performance at a glance. *This does not mean that system calibration should not be periodically checked!* However, during a busy workload, these visual checks will provide assurance to the operator that the system is functioning.

Observe the pump performance by using the Sight Flow Indicator



Assuming the system remains set up and operating at least intermittently, calibration is required perhaps every 1 - 3 months. Good record keeping of additive inventory and use levels compared to fuel handled can give a good indication that additive is on specification. Tests such as the refractometer for FSII content should be the final test to verify FSII injection ratios. SDA levels can be verified with a conductivity meter. There is currently no field test for determining CI levels, so volumetric comparison of fuel handled vs. additive consumed is the best double check for this additive.

See the section on preventative maintenance for suggestions as to regular maintenance.

SHUTDOWN AND PREPARATION FOR STORAGE

ANY additive left in the system for prolonged periods of storage will solidify and cause the unit to fail. Therefore, for any period of extended storage, be certain the system is completely purged of all additives. Using the Priming valve, it takes only a few minutes to completely clean the system for storage. Follow these directions carefully.

1. Close valve # 1 on each additive
2. If the unit is going to be inoperative for more than one week in normal summer time temperatures, or for more than 72 hours in temperatures less than freezing, the injectors should be purged of all additive with jet fuel. Make certain all the #1 valves remain closed. Open the priming valve for 30 seconds while the system is operating. After 30 seconds, turn off the fuel flow and turn off the priming valve.
3. Close the valve on the FSII drum and disconnect the swivel fitting on the ¾" suction line from the drum and secure the hose in its storage rack on the skid. Make certain to keep the end of the hose out of the dirt and thread the swivel fitting back onto its connector on the inside of the frame.
4. Upright the FSII drum and remove the ¾" valve fitting and the 2" vent from the drum. Store these accessories in the tool box on the skid.
5. For all 3 additives, make certain the Bleed and Vent valves are in the inject position and valves #1 and #2 are closed.
6. Disconnect inlet and outlet fuel hoses.
7. Replace the dust covers.

Dust covers shown installed prior to storage.

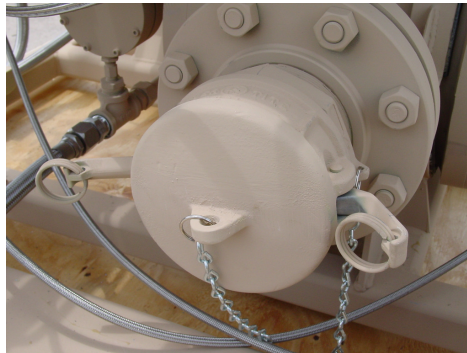

8. Unit is ready for transport and or storage.



CAUTION

FAILURE TO FOLLOW THESE PROCEDURES MAY MAKE THE SYSTEM IN-OPERATIVE DURING THE NEXT USE. A SYSTEM STORED WITH ADDITIVE REMAINING IN THE INJECTORS WILL REQUIRE HOURS OF DISASSEMBLY AND CLEANING PRIOR TO USE AND COULD JEOPARDIZE THE SAFETY AND SUCCESS OF YOUR MISSION.

TROUBLE SHOOTING THE SYSTEM

SYSTEM WILL NOT TURN

* Fuel hoses have been connected incorrectly making fuel pass through the system in the wrong direction.

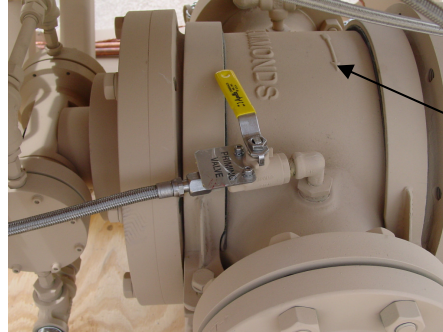

Flow arrow is cast into top of Fluid Motor housing. Fuel flow must be in same direction.

- A fuel hose is kinked upstream or downstream of the system
- A valve up-stream or downstream of the system is partially or fully closed
- A line check valve is installed in the wrong direction upstream or downstream of the injector. Sometimes, check valves are left in a hose system accidentally that were there for other reasons in a previous exercise. Be sure none exist.
- A pressure control valve at some point in the fuel system is set too low and not providing the flow / and or pressure to power the injector. Some systems have pressure control systems built in to prevent over-pressurizing an aircraft. These may be set too low for normal fuel transfer operations.
- Somehow, the fuel hose has been connected to the suction rather than the discharge side of the main fuel delivery pump. It's easy to do, some field operations may have several hoses routed from place to place. Check each end of every hose and be sure it is connected to the correct outlet.
- A rag, glove or other foreign object is jamming the injector. Check the inlet side first and using your hand, see if the Fluid Motor will rotate freely. It is somewhat difficult to turn, but it can be done.
- Check the pumping system thoroughly. There can be many reasons that a pump is not delivering the appropriate flow such as loss of prime, pressure controls not set properly, or relief valves not adjusted allowing flow to by-pass the system when under pressure.

SYSTEM TURNS BUT WILL NOT PICK UP ADDITIVE

- Check additive level in tank.
- Make sure all valves from each tank to the injectors are opened.
- Check the suction and discharge check valves on the pumps.
- There is a suction leak in the hose connections between the injector and tanks. The fittings on the Hammonds TPI-4T-4A-1 are all stainless steel. They form a

metal-to-metal seal and therefore must be very tight. Be sure to use a backup wrench and check each fitting for tightness. Use proper fitting tightening procedures illustrated below.



Always use two wrenches to back up both parts of the fitting. It is important *not* to disturb the threaded portion of fittings when loosening or tightening tube fittings.

- Make certain to open tank valves. Tanks supplied with the system have a separate vent fitting with a sintered filter, which must remain open. **Keep the filters clean.** FSII drum must be vented also.

Tank valves must be open for operation.

Valves shown closed.



Tanks have a separate vent with a sintered filter.

- A Sight Flow Indicator is leaking around the seals. Remove the cap and check the large o-rings on each end of the clear glass. Use a small amount of grease or oil to coat each o-ring, replace the glass and hand tighten the cap.

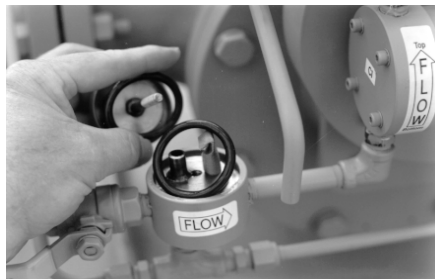

- Check the screen located in the Sight Flow Indicator for foreign material. If needed, remove the cap, glass and clean the screen

Observe the filter screen for dirt or foreign material.



- A pump has been stored with additive in the system and dried the check valves in the open position. Try to purge the system by closing all three #1 valves, then open the Priming valve and allow the system to operate for a few moments. The fuel may clear the clogged valve. Turn the Priming valve OFF and turn the #1 valves back ON. Observe the performance.
- A check valve has been fouled with a piece of Teflon® tape or other trash. This is usually on the suction side of the pump (the valve on the bottom of the fluid end). As a last resort, remove the valve and check for fouling. Be sure and re-seal the pipe fittings with tape and pipe dope if all possible.

Inspect suction check valves first.

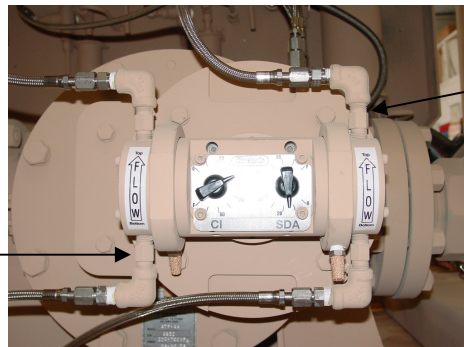

Discharge check valves.

- If the problem is the FSII pump, a diaphragm may be broken. An old worn diaphragm can begin to loose efficiency before it fails completely and begins to leak. First, the fastener in the diaphragm pulls free of the diaphragm. This causes the pump to operate partially on the pressure stroke, but not on the suction stroke, which enables the pump to receive fluid. Performance is reduced by about 50% and the pump will refuse to pull additive into the fluid end fully. If it is the FSII pump, first turn the stroke down on one side, then the other and in this way determine which fluid end is causing the greatest amount of loss in performance. In the case of the FSII injector, if one diaphragm is faulty, chances are, both should be replaced, even if the remaining one seems ok. They each have the same amount of wear since new.

Be sure to follow the instructions on replacing the diaphragms carefully found in the maintenance and repair section.

- If the problem pump is either CI or SDA, replace the appropriate plunger seal.

Check for additive leaks at each vent filter.

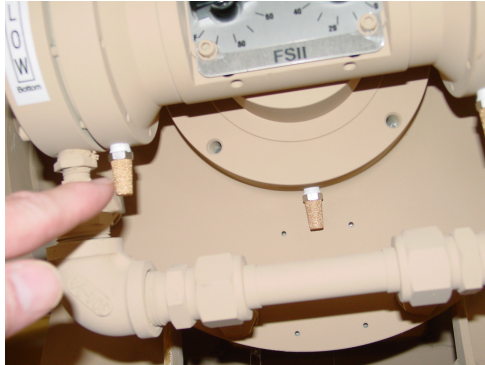

- The additive supply hose has a pin hole leak that is not visible. Since there is a vacuum present on the suction side of the injectors, it is possible to have a leak in the hose without seeing a visible leak. These leaks are very hard to detect, and will only leak when the unit is not operating. A leaking hose may only show up as dampness on the hose exterior. Ultra violet, temperature and abrasion are hard on some additive hoses.
- Check stroke adjustments and make sure the locking setscrew has not vibrated loose and allowed the adjustment to move. If the stroke adjustment cam is not securely locked in place, it will have a tendency to move back to “100%” on it’s own. Check the stroke adjustments to be sure they have not vibrated loose during shipment or from the previous use.



The injector pumps use screws for locking the stroke adjustment. **CAUTION, Do not over-tighten these screws. Doing so will damage or break the cam.**



INJECTORS ARE PRIMED, SYSTEM IS TURNING BUT INJECTION IS EITHER LOW OR ERRATIC

- Check additive levels
- Check connections including tube fittings on each end of each additive hose
- Check vent on tanks, must be open
- Check screen in Sight Flow Indicators
- Be sure all valves in additive line are fully open
- Make sure stroke adjustments have not slipped
- Check the diaphragm. A diaphragm may not be leaking but still need replacement.

- Check the check valves, particularly the suction valves on the bottom of each fluid end in question for trash or sludge from previous dried additive left in the system.
- Check the performance ratio of Fluid Motor. The Fluid Motor will rotate .4 revolutions for every gallon of fuel that passes through the system. Establish a flow rate in GPM, remove the *FSII* pump cam guide cover, and count the revolutions for 30 - 60 seconds. Example: 400 GPM X .4 = 160 rpm. If the counted rpm is off more than 20%, the Fluid Motor may have excessive wear internally and need vane replacement. Note: Do not count the output shaft rotations on the CI and SDA pumps. This shaft exits a 3:1 reduction. The FSII pump operates at direct 1:1 motor speed.
- Check stroke adjustment knobs on the injectors when the system is running. If the screws that secure the various power frame parts have worked loose, the stroke adjustment cam and knob will move about. Remove the knob, cover and check the fasteners. See exploded view of the system in the maintenance section. This should not occur with the heavy duty model pumps included on this system.
- CI and SDA additives may be too thick due to low temperature and out-of-ratio blending. In most cases, neat (concentrated) CI and SDA are blended with jet fuel at ratios of 19:1. This enables the ratio to be injected at 20 ppm rather than 1 or 2 ppm. The higher ratio is much easier to calibrate and measure under field conditions. If this “cocktail” is not mixed properly, or if the additive has been exposed to atmosphere for long periods of time, the viscosity (thickness) of the additive may have increased making it difficult to pump.
- Temperature is too low causing the additive to be hard to feed. If the additive cannot be warmed for thinning, it may be necessary to increase the stroke during the colder temperatures.
- Remember: 99% of all pump problems occur because of suction problems.

THE INJECTOR IS RUNNING SLOW EVEN WITH HIGH FUEL FLOW RATES

- Vanes may be excessively worn. See previous section on checking motor ratio.
- Check the system flow rate. The system does not reach optimum efficiency until the rate exceeds 150 gpm. Be sure the pump system is delivering the proper volume of fuel. Since fuel handling is most often associated with equipment that generate high noise levels, you cannot depend on the sound of the injector to indicate fuel flow rate.

THE INJECTOR WILL NOT FLOW AT ALL AND APPEARS TO BE LOCKED UP

- The motor has thrown one or more of the vanes. Remove the FSII pump side cover plate and inspect the vanes.
- Check the inlet for foreign objects such as a rag or glove.

THE INJECTOR HAS BEEN DISASSEMBLED AND RE-ASSEMBLED BUT NOW WILL NOT TURN AT ALL REGARDLESS OF FUEL FLOW RATES.

- The rotor has been installed backwards allowing flow to pass around the rotor and vanes without causing rotation. See the illustration below. If necessary, remove the rotor, and orient the vanes correctly.

Illustration shows FSII pump and side plate removed, exposing Fluid Motor internals and configuration of rotor and vanes.

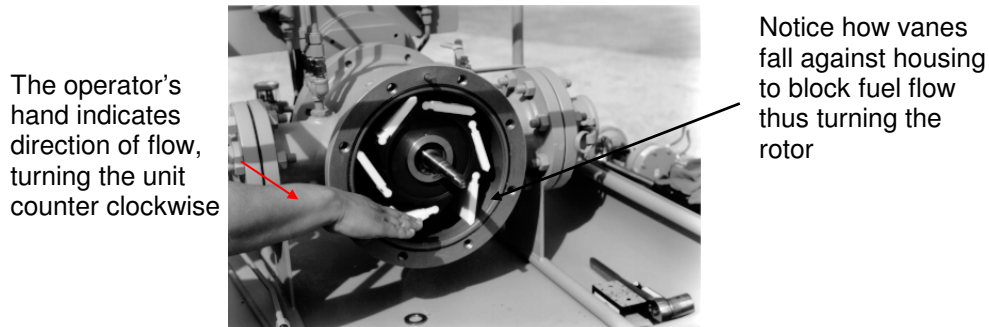

- The hoses have been connected incorrectly. The system will operate with fuel passing through the system in one direction only. See the arrow cast into the top of the Fluid Motor housing. Reverse hoses if necessary.

.....A few tips to remember

- Pumps do not *suck* fluid, they *push* the fluid. Additive *must* be supplied to the pump. This is called providing a *flooded suction*. Although the injectors can be forced to lift, they work best when flooded with a supply of additive.
- 99% of all pump problems result from problems on the *suction* side of the system. That is, within those components between the additive tank and the injector, and that includes the tank. Leaks, obstructions, anything that can restrict the free flow of additive to the system will effect how the system works.
- The TPI-4T-4A-1 is powered by fuel. Without fuel flow, there is no injection. There can be many components in the system before and after the TPI-4T-4A-1 that can affect the flow of fuel. Be sure you have adequate flow to the system before deciding that something is wrong.
- Take a few minutes to study and understand how the system works.

PREVENTATIVE MAINTENANCE

FLUID MOTOR

- Be sure the motor inlet and outlets are kept closed to dust and dirt.
- Check seal vent filters in each side of the Fluid Motor as illustrated below for any signs of jet fuel. There is a mechanical seal on each end of the motor shaft. If this seal begins to leak, fuel will leak from these filters. Mechanical seals will not normally fail suddenly, but begin to *weep* slowly, with the leak gradually getting worse over a period of time.

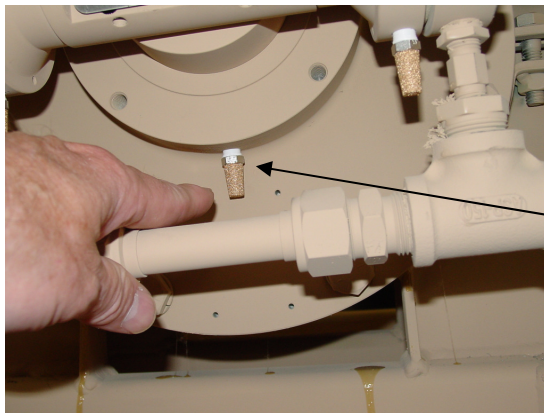

Check vent filter on each side of Fluid Motor for signs of fuel leakage.

- The internal Fluid Motor and seals require no preventative maintenance unless the system shows signs of not performing properly or leaking. Providing the system is not operated at flow rates above 700 gpm, and foreign material such as dirt or sand has not been allowed into the system, the main drive vanes in the Fluid Motor will last for hundreds of hours of trouble free operation. A gradual reduction in motor performance will occur with age, but can be compensated for by increasing injection pump settings. It is suggested that major maintenance on the Fluid Motor be done only when a fuel leak is present or if the injectors cannot be calibrated to specification.

INJECTOR GEAR REDUCER

- The CI and SDA injectors are driven through a 3:1 ratio speed reducer. The gears in the reducer are packed at the factory with grease. Additional grease can be added with a conventional grease gun on the zerk fitting as indicated below. Grease this fitting after every 100 hours of operation. Inject grease until excess exits the vent next to the zerk fitting. Wipe off excess so that dirt will not be attracted. See following illustration showing CI and SDA side of system.

Zerk fitting on speed reducer.

Use a conventional grease gun with chassis grease after every 100 hours of operation.

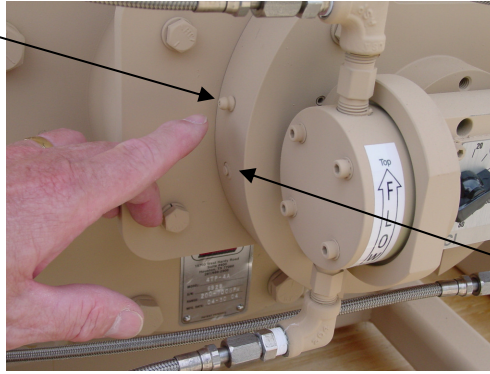

Inject grease until excess exits vent plug. Wipe away excess.

INJECTOR MAINTENANCE

- Lightly grease the area around the drive bearing on both pumps with LUBRIPLATE® grease supplied in the pump repair kits. Do not fill the cavity between the round bearing and crosshead nor the area between the cross head and pump power frame. Only a light coat of grease is required. If grease appears to be contaminated with dirt or sand, the area should be flushed with solvent and fresh, clean grease applied. Check this area every 50 hours or as needed depending on the operating environment.

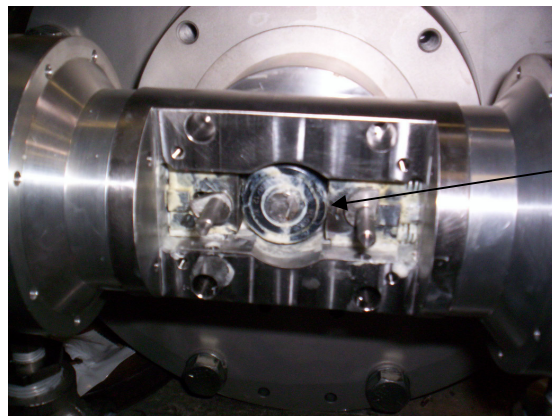

Lightly coat the bearing and internal moving parts with grease supplied. Packing with grease will adversely affect performance.

- The life of diaphragms and plunger seals vary with application. CI and SDA plunger seals can last for millions of gallons of fuel since they operate very slowly and at a very short percentage of stroke. The FSII pumps may however, need replacement sooner. Diaphragms used every day on an intermittent basis typically last from one to two years. Spare diaphragms should be on hand during extended deployment (over 6 months) or under severe operating conditions (over 6 hours per day). It is a good policy to replace all diaphragms following an exercise, assuring that the system will be fresh following storage for the next deployment. For equipment that is used daily in a semi-permanent operation, it is suggested diaphragms be replaced every 12 months as regular maintenance.
- The internal parts of the injectors will typically last for many years. The CI and SDA pumps as well as the FSII pump uses all heavy duty metal components. Keep these parts lightly greased and all fasteners tight.

- Check valves (two on CI & SDA pumps and four on FSII pump) will normally perform for hundreds of hours if kept clean and free of trash. They must perform properly in order to maintain consistent injection ratios. No regular maintenance is required if the system is performing satisfactorily. When performance is in question and valves are suspect, they should be disassembled and cleaned thoroughly. Be certain to replace all parts as they were disassembled. *It is absolutely necessary to install the valve with the arrow stamped on the side of the valve pointing in the direction of additive flow. Installing the valve backwards will prevent the pump from operating.*
- The drive bearing located in the center of each injector pump is permanently lubricated and sealed. Again, depending on severity of service with respect to fuel flow rate and line pressure, these bearings will function for several years under daily use. Inspect the bearing by adjusting the stroke adjustment on each fluid end to zero. This will remove pressure contact from the bearing and allow the operator to feel the amount of “play” in the outer surface of the bearing.



CAUTION: *Do not attempt to check the bearing when the system is operating. Doing so will mash your finger as the bearing rotates within the pump power frame.*

- Check and clean the screens in the Suction Sight Flow Indicators. These screens should be visually inspected daily and cleaned as necessary.



- Inspect all connections and tube fittings between tank and system. Inspect all pipe and tube fittings on injector for leaks. Remember: a leak on the suction side of the system (between the injector and tank) will cause problems.

.....**A few maintenance tips to remember**

- It is never convenient to repair an un-expected failure. Scheduled maintenance is faster, easier and cheaper to perform.
- This is a fluid handling system-----keep all the fluid connections tight.

ASSEMBLY AND DISASSEMBLY INSTRUCTIONS

PUMPS - DISASSEMBLY

The following instructions detail the disassembly and re-assembly of a complete system. Steps 1 thru 3 are concerning the CI and SDA injectors. Beginning with Step 4, the FSII pump removal is detailed. To service the internals of either injector, review the section titled, "MAJOR INTERNAL PUMP SERVICE" that follows this section of the maintenance instructions.

CI and SDA INJECTORS...pump removal

Step 1 Disconnect the flexible hoses on suction and discharge side of injector. Tag each hose so it won't be crisscrossed. This would prevent the pump from functioning properly.

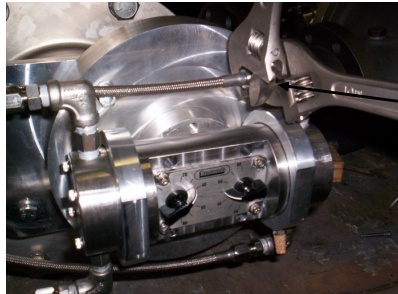

Be sure to use a backup wrench on all fittings. Do not loosen valve in fluid end.

CAUTION: Additive may be trapped in the manifold.

Step 2 Loosen the set screws and remove the adjustment knobs, stroke indicator plate, and cam guide/cover.



Mark your settings on the cover before removing knobs and cover

Note: To change plunger seals, it is not necessary to remove the pump completely from the driver. See pages 40 & 41

Step 3 Remove the fluid end screws and fluid end to access the plunger.

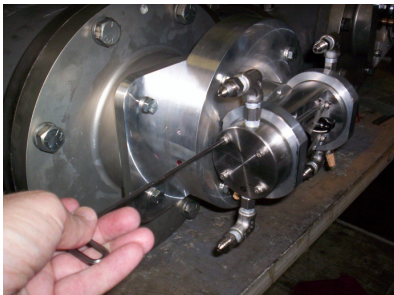

Note: Refer to exploded view drawings for the CI and SDA pump internal parts.

FSII INJECTOR

Service tip: For diaphragm replacement, follow Steps 4 thru 8.

Step 4 Loosen tube fittings on suction and discharge on *one side only*.

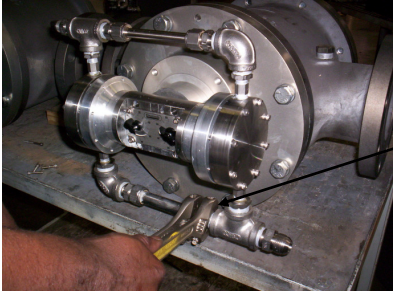

Be sure to back up all fittings with second wrench. Do not loosen fitting pipe threads

Step 5 Remove head screws.

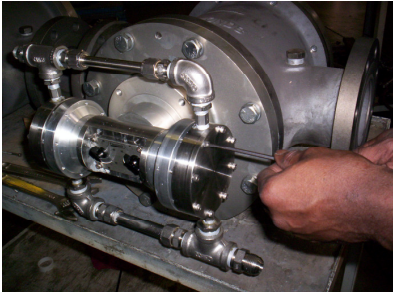

Remove head screws and head only if diaphragm service is required, otherwise it is not necessary to remove the head in order to remove the pump. Follow procedures in diaphragm service procedures carefully.

Step 6 Remove entire fluid end assembly

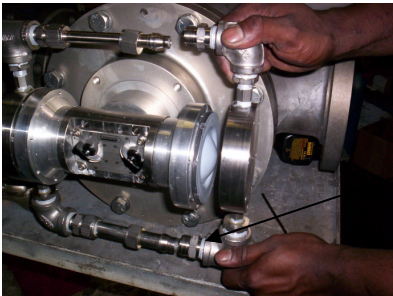

CAUTION: Additive may be trapped in the manifold.

Step 7 Remove the diaphragm by rotating counter-clockwise.

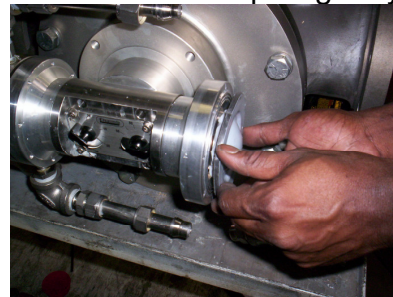

Service Tip

Removing the diaphragm is easier if the stroke adjustment is first adjusted to zero. This extends the diaphragm so that it is easier to grasp. Be sure and mark the position on the dial before disturbing the setting. Loosen setscrew before moving cam.

Step 8 Remove the diaphragm and inspect for wear or delamination of the thin Teflon® layer and rubber backing.

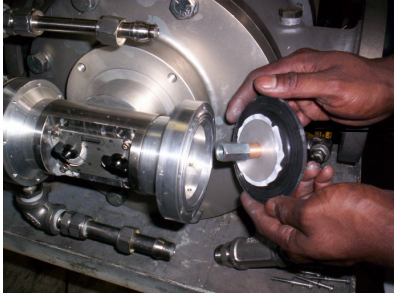

Check diaphragm for evidence of leakage, deterioration or distortion around outer edge. FSII will quickly dissolve the backing material. Also check tightness of fastener. Long service will sometimes pull the fastener out of the diaphragm.

Step 9 Loosen the setscrews and remove the adjustment knobs, stroke indicator plate, and cam guide/cover.

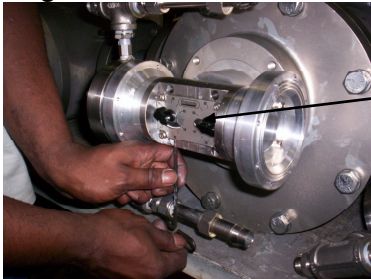

The adjustment knobs are secured with a small setscrew in the end.

Step 10 Remove the remaining head and diaphragm as shown in Steps 5 thru 7. Remove the snap ring holding the drive bearing. **Service tip:** temporarily install the cams and adjustment knobs and rotate the knobs to move the crossheads off the bearing. Remove the drive bearing. Pull the cams out. The crossheads may now be removed.



Caution: the crossheads are spring loaded.

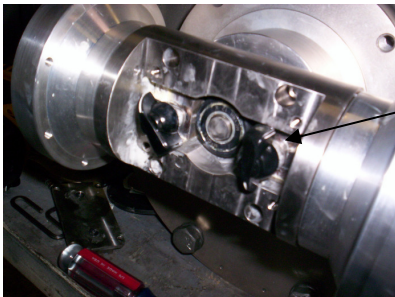

Rotate knobs to clear bearing. Remove bearing, pull cams out.

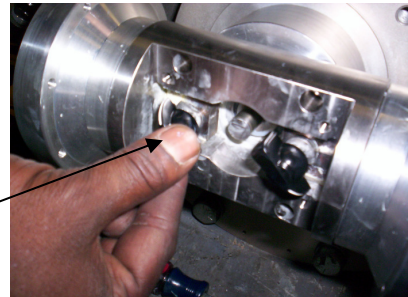

Step 11 Remove the four #10 screws and two 5/16" screws holding the power frame to the Fluid Motor. Remove the entire pump power frame.

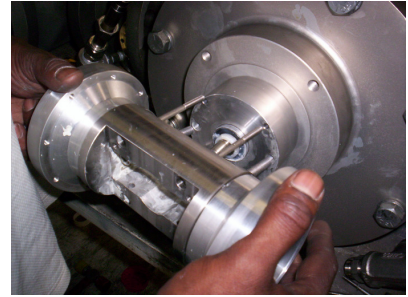
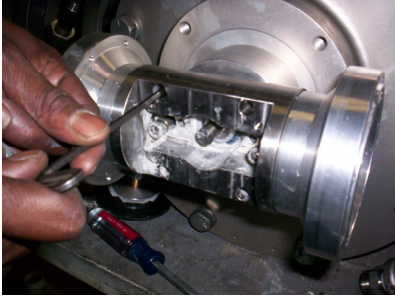

Step 12 Remove the bearing, bearing spacer and pump mounting block

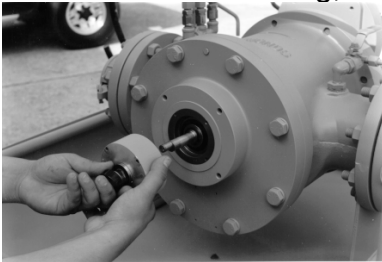

SERVICE TIP
It is a good idea to lay these parts out in order as they are removed. Re-assembly can go much faster if you are sure of the order in which the system was disassembled.

Step 13 Remove the snap ring and flat spacer washer

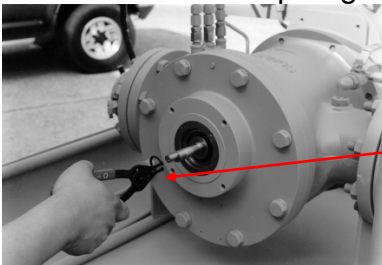

Use the correct size of snap ring pliers. Pliers that are too small can distort the ring.

Step 14 Remove the side plate bolts

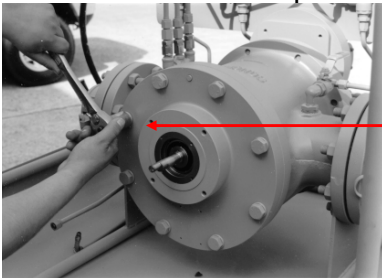

Remove bolts in a crisscross pattern in order to reduce un-even stress on the side plate.

Step 15 **CAREFULLY** remove the side plate. Try not to drag plate on shaft.

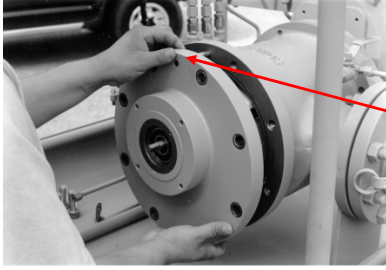

Support the side plate evenly with both hands. Note the alignment pin at the top of the housing.

Step 16 Examine the vane position and how they lay against the housing.



Notice the discharge vent in the housing in relationship to the vanes.

Step 17 Check each vane for freedom to fall against the housing. Check for excessive wear in the vane socket. If it appears that the vane could be pulled out of the socket, it should be replaced. Normally, vanes are replaced by the set, not individually and performance would be rough with one new vane and six worn ones remaining.

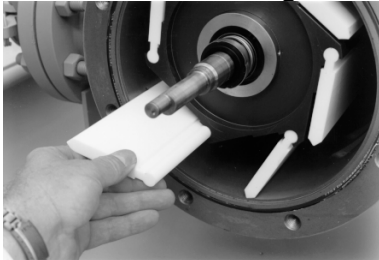

It is normal to see some wear in the center of the vane in the same position as the discharge vent of the housing. Vanes with considerable wear can be calibrated to perform at higher flow rates, but may not hold ratio at the lower flows. For some applications, this may be acceptable.

Step 18 **CAREFULLY** remove the seal bellows and carbon seal face.

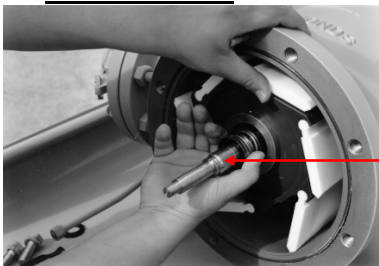

Try not to touch the face of the carbon rotating member **DO NOT DROP THE CARBON SEAL.**

Step 19 Remove the wear ring. On later models the wear rings are larger, but the process is similar.

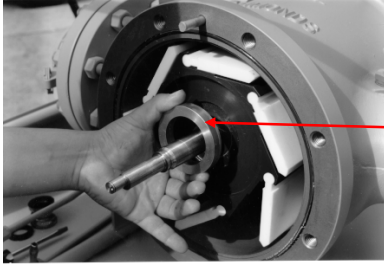

There is a wear ring in each end of the rotor. Careful not to drop the other ring.

Step 20 Remove and inspect the rotor. Check for wear, breakage or looseness of vanes in their sockets. Check for wear of the anodized coating especially on each end. Worn coating indicates un-level operation and/or a worn wear ring in each end of the rotor recess.

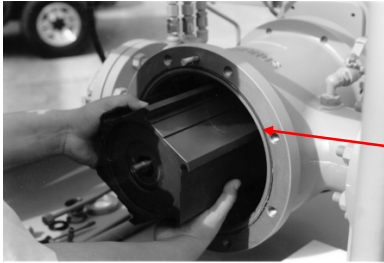

Use both hands to remove the rotor. The rotor weighs 28 pounds. Be careful!



CAUTION
The rotor has very thin vane sockets that bend and or break easily. Be very careful when setting the rotor down not to damage these fragile ears.

Step 21 Examine both the shaft and housing.

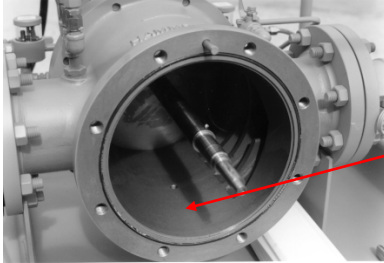

Examine the housing carefully for scratches. Check the end plates also. The system will operate with some scratches in these surfaces, however, they may increase the wear rate of the vanes and reduce efficiency in the lower flow ranges of the system.

RE-ASSEMBLY OF THE FLUID MOTOR

From this point, the instructions will guide you through re-assembly. Follow each step carefully, paying particular attention to direction of flow and details of the mechanical seal.

Step 22 In preparation for re-assembly, be sure the two (2) drive keys are in place on the shaft. There is one on each end of the rotor shaft.

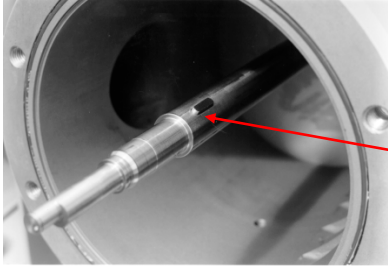

Be certain that both drive keys are fully pressed into their groove to accept rotor. A key that is raised only a few thousandths of an inch or one that has burrs will make re-installation of the rotor difficult if not impossible.

Step 23 Install the wear rings in the rotor. To re-install the rotor, align the rear end of the rotor with the front drive key and gently slide the rotor all the way onto the shaft. Check the position of the visible drive key. Place a light film of grease on both sides of each wear ring before re-installing. This will help keep the wear rings in place.

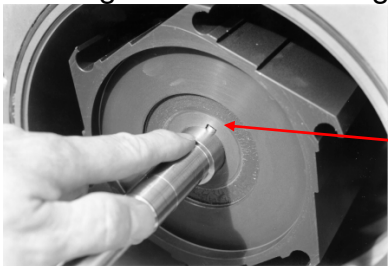

Be sure the key is in place and the rotor is all the way in. Check the proper direction of flow



CAUTION

Be absolutely sure that the rear wear rings have been installed and the direction of flow is correct. If the rotor is in backwards, it will not turn under flow.

Step 24 Re-install the vanes.

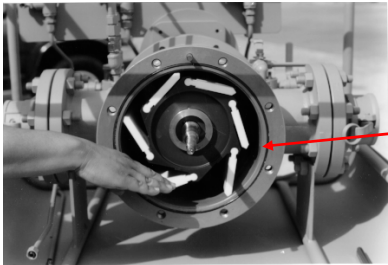

Make certain the rotor and vanes are installed as shown to trap the flow of fluid. **Be absolutely sure** the rotor is correct as indicated. If installed backwards, fuel will simply close the vanes and not turn the rotor. Match flow with arrow on housing.

Step 25 To re-install the mechanical seal, first examine the parts and understand the function of each part. Mechanical seals are very delicate. Be sure your hands are clean and you have a clean work area.

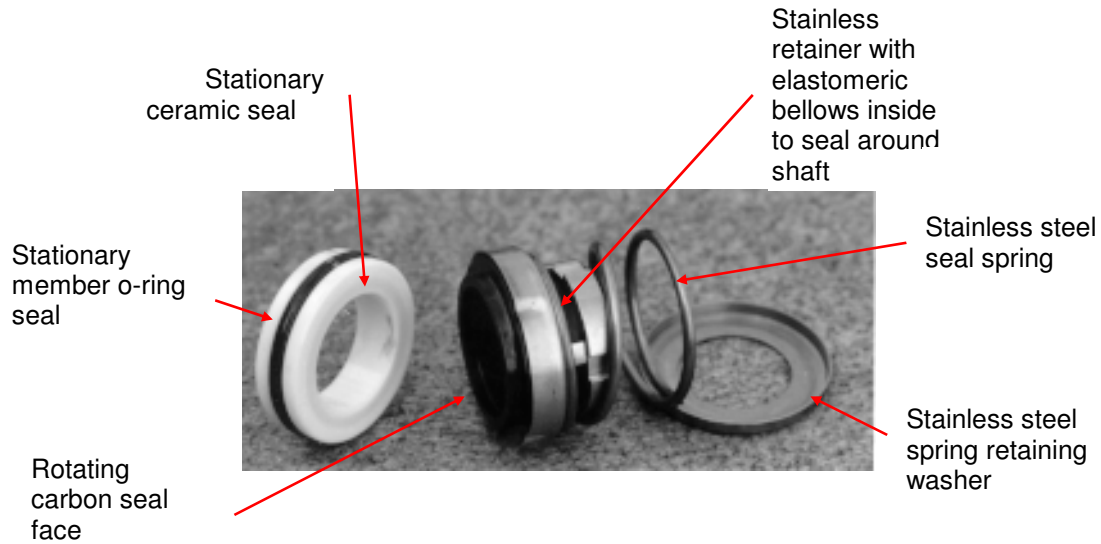

Note: Follow the next few steps to the letter. One piece of dirt or the smallest scratch can cause the seal to leak. Remember, there are two of these seals, one at each end of the main Fluid Motor shaft located in each side plate.

Step 26 Apply a thin film of motor oil to the Fluid Motor shaft.

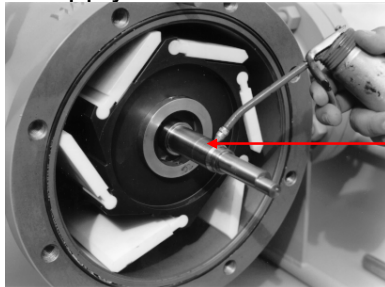

Use your fingers to distribute the oil around the entire exterior of the shaft.

Step 27 Install the stainless steel washer, spring and bellows housing ***only, do not install the rotating carbon seal yet.*** Place it on a clean cloth for installation in the next step. Use both hands to slide the assembly on the shaft all the way up next to the rotor.

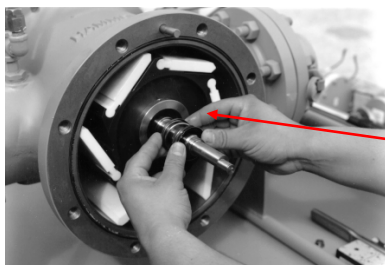

Install the pieces in this order...First the washer so that the lip retains the spring, then the spring, and finally the bellows housing *without the carbon seal.*

Step 28 Install the rotating carbon seal with small side out.



Now install the rotating carbon seal into the stainless bellows housing with the narrow or small surface facing out.



CAUTION: Try not to touch the face of the seal. The seal should fit recessed into the housing with the small indentions matching those dimples in the housing. If these do not match, and the seal is all the way into the housing, the seal will not only leak, but will be broken as soon as the side plate is re-installed. See figure below.



Be sure the small dimples match the indentions in the carbon seal

Step 29 In preparation for installing the new ceramic seal in the motor side plate, remove the old ceramic seal out of the side plate pushing it out from the opposite side. The bearing will have to be removed first. You may be able to remove the bearing by simply using your finger through the bore of the bearing, carefully pulling it clear of the housing. Otherwise, use a non-metallic object to reach through the center of the seal on the opposite side and push the bearing clear of the housing. Now apply a film of oil to the external o-ring seal of the stationary ceramic seal. **Careful not to get oil on the seal face.**



Also apply a film of oil to the bore where the seal will be installed in the Fluid Motor side plate. The oil will make insertion of the delicate ceramic seal easier. Install the shiny side facing up or to the inside of the housing just as the seal was packed from the factory.

Step 30 Now gently lay the ceramic seal, shiny face up in the bore of the side plate, and lay the round cardboard protector shipped in the seal from the factory on the seal face. Using both thumbs, gently push the seal into place. Use even force, and rotate the force being sure it is all the way into the bore.

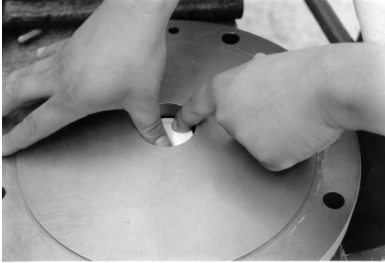

Using a clean, lint free cloth, wipe the surface of the ceramic seal, and examine the surface for any dirt or foreign material.

Step 31 Re-install the o-ring in the housing face using a film of light grease to hold the o-ring in the groove.

Step 32 Re-install the side plate, installing the bolts and tightening in a crisscross pattern. Remember, a leak free seal does not depend on tightness as the o-ring is compressed when the side plate and the housing are mated face-to-face. Just snug the bolts until the lock washers are compressed flat.

Step 33 Install the wave spring washer in the side plate bore.

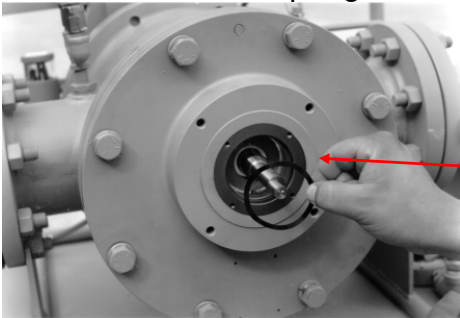

The wave washer is used on each end of the Fluid Motor shaft to place tension on the shaft, and center the entire assembly between the two side plates. It is a very important part. Do not forget to install it.

Step 34 Install the bearing.

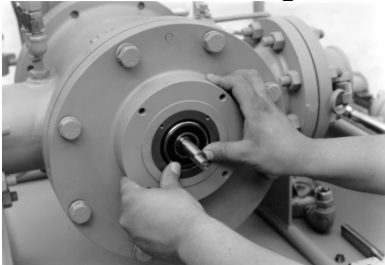

CAUTION - READ THIS FIRST BEFORE INSTALLING THE BEARING. Use very gentle, even force, to install the bearing. It will be necessary to pick up on the shaft somewhat since the weight of the rotor causes some deflection. Be careful not to attempt to push the bearing in one forceful push, this will cock the bearing and prevent any movement at all. Use very, very light touches all around the bearing at two points on opposite sides.

Step 35 Install the flat spacer washer and then the snap ring.

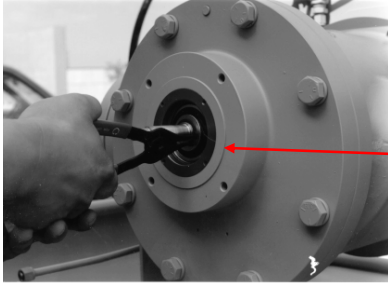

*Don't forget the
flat spacer
washer!*

Step 36 Complete the re-assembly by installing the pump mounting block, the pump and re-connecting all the fittings. Refer to the disassembly steps at the beginning of this section.

SO WHAT ABOUT THE OTHER SIDE PLATE, SEAL AND PUMP?

We have used the FSII side of the system to demonstrate the procedure. It could have been done from the other side. We suggest that ***only one*** side be disassembled at a time. If a seal is leaking, disassemble the side with the leak. Leave the other side in place. As you can see, the entire procedure can be performed from one side. It makes for a much easier re-assembly if the shaft and related parts are supported.

MAJOR INTERNAL PUMP SERVICE

PUMPS - REASSEMBLE (applies to either CI and SDA or FSII pumps)

Refer to this exploded view of the various internal parts of the pump. The power frame is the same for both the CI/SDA pump and the FSII pump. The larger FSII fluid ends and adapters are illustrated at the end of this section. Refer to the assembly drawings and parts lists to determine part numbers.

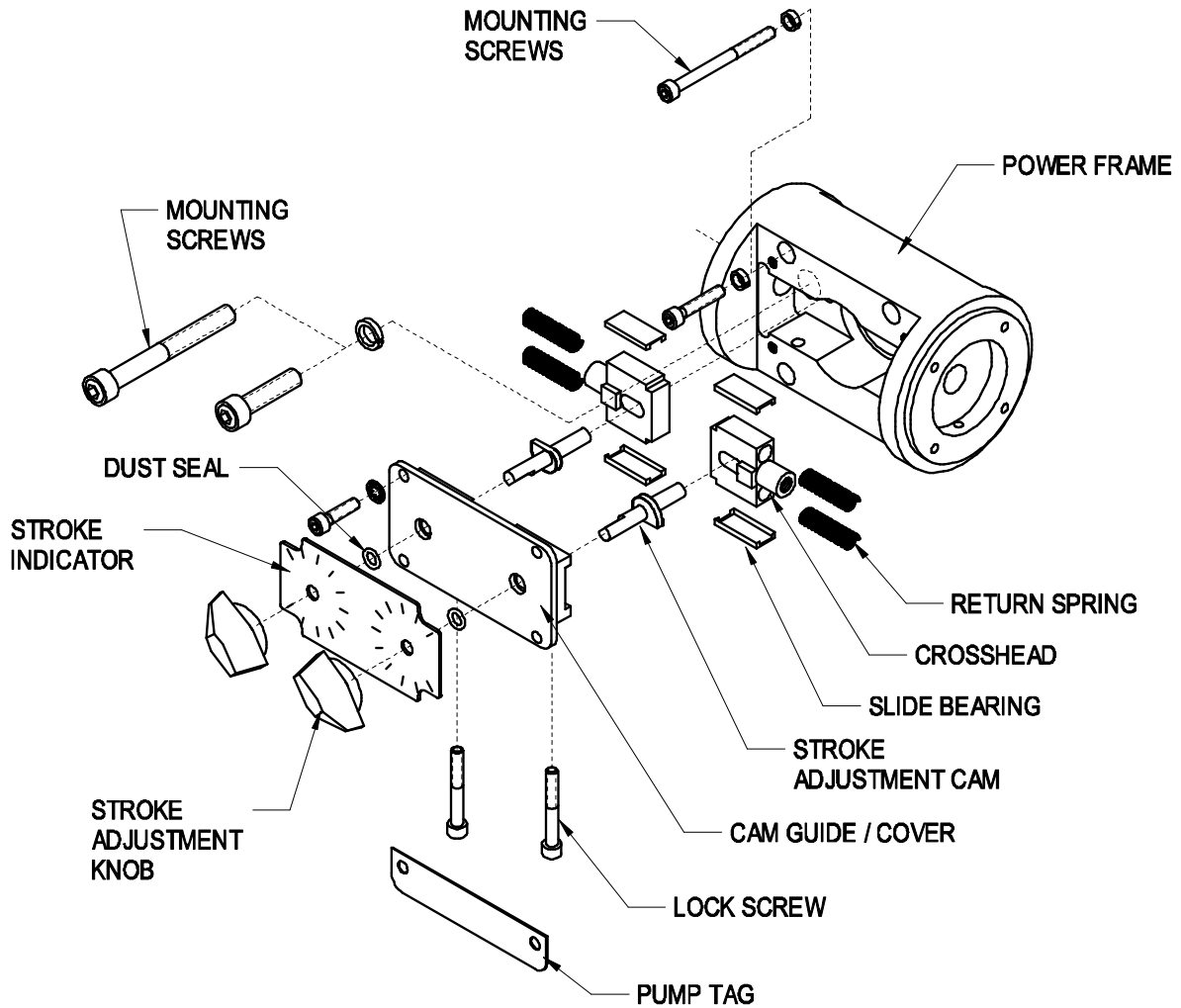

PUMP RE-ASSEMBLY

The following instructions give important tips and detail the re-assembly of a stainless model power frame. It is assumed that the exploded view illustrations later in the manual provide sufficient instructions for disassembly.

Step 1 Install the plastic slide bearings on each side of the cross head.

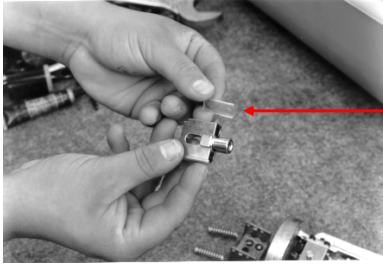

Apply a small amount of grease on both sides of the plastic slide bearing. The grease not only lubricates the bearings, but acts as a cushion between the bearing and crosshead.

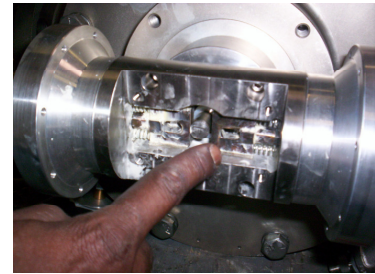

Step 2 Apply grease lightly under the crosshead and on each side and inside the walls of the power frame cavity, then place two springs in the holes on the end of the crosshead.

Step 3 Install the crosshead, with the square boss facing out and threaded nose pointing through the hole in the power frame.

Step 4 Insert the stroke adjustment cam through slotted hole located in the crosshead until it is fully seated in the receiving hole located in the pump frame. Install the adjustment knobs and tighten the setscrews in each knob. Rotate the knobs to move the crossheads out of the way to install the drive bearing. Install the snap ring holding the drive bearing in place. Apply a small amount of grease to the outside surface of this bearing.

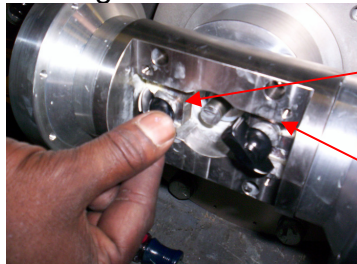

Rotate knob to move crosshead.
Install bearing and snap ring.

Apply a thin coat of Permatex® sealant to this area.

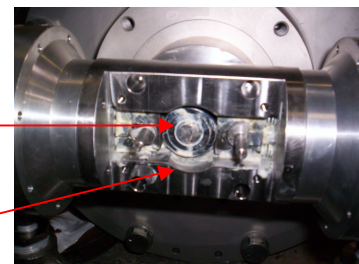

Step 5 Apply a thin coat of Permatex® sealant to the flat area under the cam guide/cover to seal the pump cavity from dirt.

Step 6 Remove the adjustment knobs one more time to install the cam guide/cover over the cam shafts and install the 4 screws.

Step 7 Install the dust seal, small o-ring over each cam shaft. Use a small amount of grease to ease installation completely into the groove around cam shaft. The o-ring must be flush with the top of the cam guide/cover.

Step 8 Install the adjustment knobs. Adjust the knobs to the stroke setting, the mark you made earlier. Secure the setting by tightening the lock screw below.

CI / SDA PUMP PLUNGER & SEAL SERVICE

Step 1 Disconnect the flexible hoses on suction and discharge side of injector. Tag each hose so it won't be crisscrossed. This would prevent the pump from functioning properly.

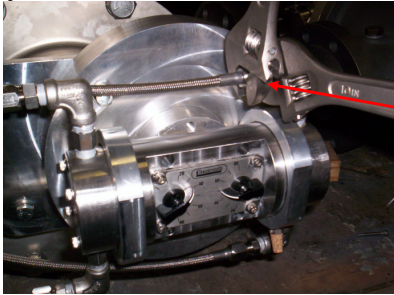

Be sure to use a backup wrench on all fittings. Do not loosen valve in fluid end.



CAUTION: Additive may be trapped in the fittings and hoses.

Step 2 Remove the fluid end screws and fluid end to access the plunger and seal.

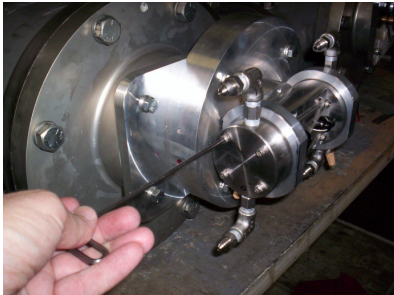

CAUTION: Pay careful attention to the bottom to top flow direction of the fluid end assembly. This is very important for re-assembly and proper pump operation.

Step 3 The fluid end slides off the plunger. If the plunger seal does not remain positioned on the plunger, simply pull it out of the pocket in the fluid end as pictured. Inspect the surface of the plunger for any scratches. If any wear is found, replace the plunger. Unscrew the plunger using a standard flat blade screwdriver.



Plunger

Plunger seal

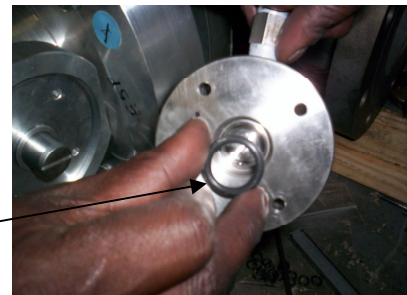

Step 4 Remove the seal adapter and inspect the condition of the rubber lip seal. Replace this seal if any signs of wear are present.

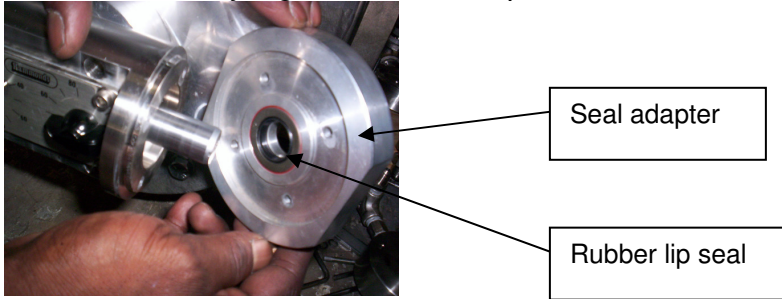

Refer to the exploded view drawings that follow for both CI/SDA and FSII injectors. These drawings demonstrate the application of both small (for CI and SDA) and large (for FSII) fluid ends.

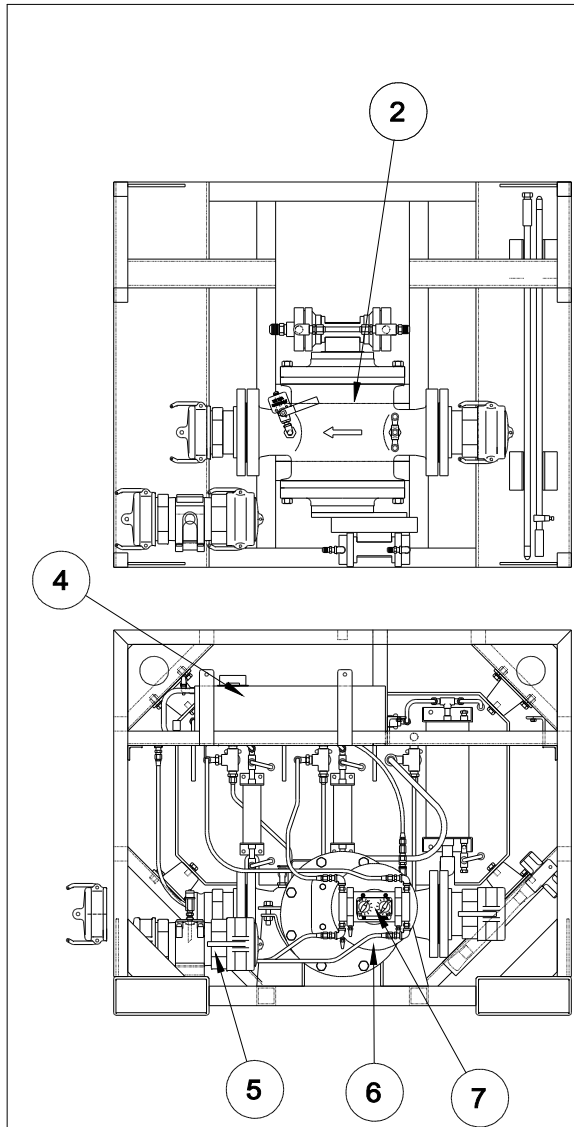

ITEM	PART NO.	DWG. NO.	QTY.	DESCRIPTION
1	4TP-4A SKID	4933	1	SKID SUB-ASSEMBLY
2	800ER-2L-1P7-1P7	4935	1	INJECTOR SUB-ASSEMBLY
3	102489	4932/4932A	1	CONTROL PANEL SUB-ASSEMBLY
4	212013	3990A	2	6 GALLON SS TANK SUB-ASSEMBLY
5	102491	4934	1	4" SAMPLE PROBE SUB-ASSEMBLY
6	883745	1694	1	3:1 GEAR REDUCER SUB-ASSEMBLY
7	1P7-1P7	5655	1	1P7-1P7 PUMP SUB-ASSEMBLY (CI-SDA)
8	2L	5547	1	2L PUMP SUB-ASSEMBLY (FSII)
9	882378		1	FSII SAMPLE TEST KIT

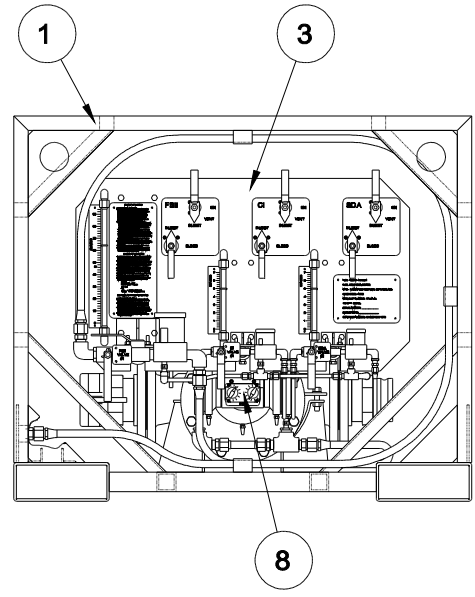
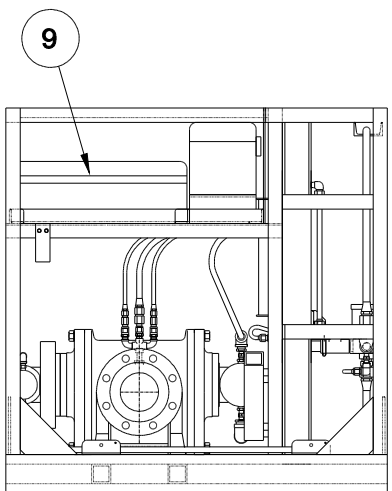

<table border="1"> <tr> <td>NO.</td> <td>REVISION</td> <td>DATE</td> <td>BY</td> <td>APPVD</td> </tr> <tr> <td></td> <td>X</td> <td></td> <td>X</td> <td>X</td> </tr> </table>					NO.	REVISION	DATE	BY	APPVD		X		X	X	<table border="1"> <tr> <td>DRAWING</td> <td>LEVELS</td> <td>VIEW</td> </tr> <tr> <td>1839</td> <td>66, 67, 72, 73, 77-80, 115, 137, 140, 142, 152</td> <td>1</td> </tr> </table>			DRAWING	LEVELS	VIEW	1839	66, 67, 72, 73, 77-80, 115, 137, 140, 142, 152	1	<p>*TOLERANCES* ALL DIMENSIONS ARE IN INCHES UNLESS OTHERWISE SPECIFIED.</p> <p>*TOL. DECIMALS: .XXX= +/- .005 .XX= +/- .015 .X= +/- .030 FRAC. = +/- 1/16</p> <p>*TOL. ANGLES: +/- .5 DEGREES</p> <p>*CONCENTRICITY: .005 T.I.R.</p> <p>SURFACE FINISH: 125 *REMOVE BURRS AND BREAK EDGES .005 MIN.</p>		<p>THIS PRINT IS CONFIDENTIAL AND IS THE PROPERTY OF HAMMONDS TECHNICAL SERVICES</p> <p>THIS PRINT SHALL NOT BE USED, COPIED OR REPRODUCED IN WHOLE OR IN PART WITHOUT THE WRITTEN PERMISSION OF HAMMONDS TECHNICAL SERVICES.</p>		<p>HAMMONDS TECHNICAL SERVICES, INC.</p> <p>SCALE: NTS DATE: 03/10/04 DRAWING TITLE: HAMMONDS MODEL TPI-4T-4A-1</p> <p>PART NUMBER: TPI-4T-4A-1 DRAWN BY: SS REVISED: -</p> <p>FUEL ADDITIVE INJECTOR DRAWING NUMBER: 4832A</p>		
NO.	REVISION	DATE	BY	APPVD																										
	X		X	X																										
DRAWING	LEVELS	VIEW																												
1839	66, 67, 72, 73, 77-80, 115, 137, 140, 142, 152	1																												

NOTES:

- 1) FOR REAR VIEW OF PANEL ASSEMBLY....SEE DRAWING #4932A
- 2) FOR ITEMS REFERENCED SEE SEPERATE PARTS LIST

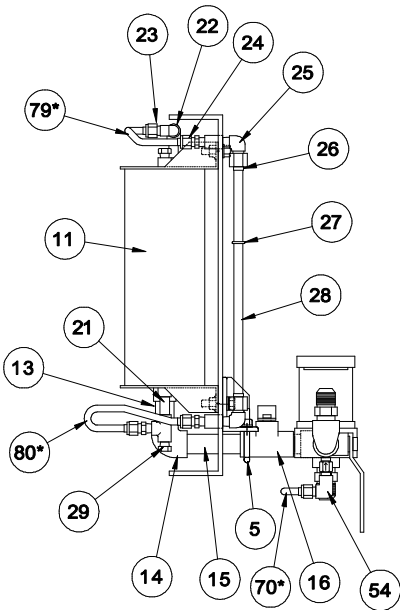
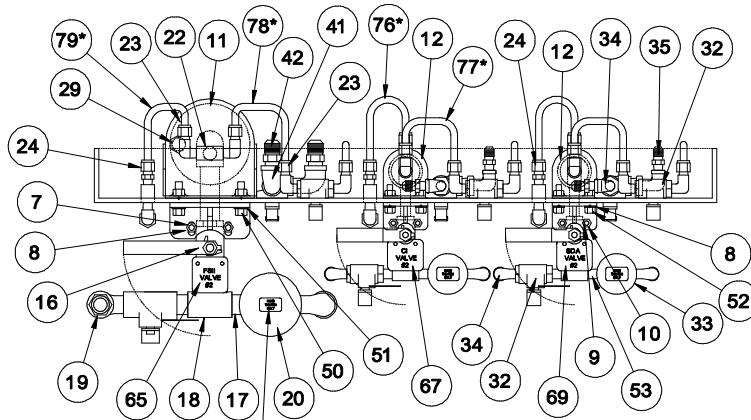

SECTION A-A

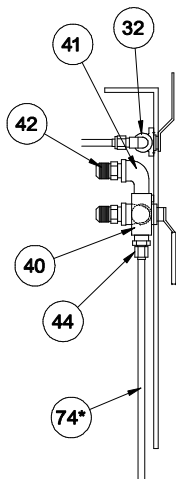

SECTION B-B

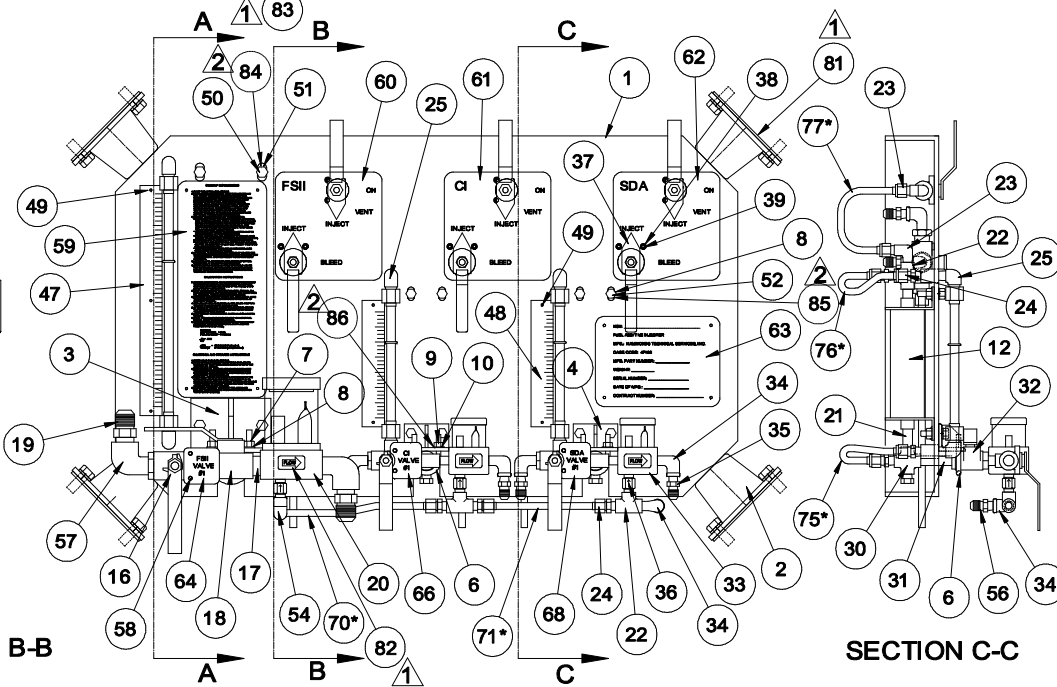

SECTION C-C

NO.	REVISION	DATE	BY	APPVD	DRAWING	LEVELS	VIEW
					X	X	X
ADDED 84,85,86		05/27/14	SS	X	1839	97, 121-123, 125, 126,	1
ADDED 81,82,83		05/23/14	SS	X		128-130, 138, 143, 153	
INITIAL RELEASE		09/10/04	SS	X	FROM SER#	DATE	TO SER#
					X	X	X

TOLERANCES
ALL DIMENSIONS ARE IN INCHES UNLESS OTHERWISE SPECIFIED.

***TOL. DECIMALS:**
XXX ± .005
XX ± .015
X ± .030
FRAC. = ± 1/16

***TOL. ANGLES:**
± .5 DEGREES

***CONCENTRICITY:**
.005 T.I.R.

***REMOVE BURRS AND BREAK EDGES .005 MIN.**

THIS PRINT IS CONFIDENTIAL AND IS THE PROPERTY OF HAMMONDS TECHNICAL SERVICES

THIS PRINT SHALL NOT BE USED, COPIED OR REPRODUCED IN WHOLE OR IN PART NOR SHALL THE CONTENTS BE REVEALED TO ANY PERSON TO WHOME UNLESS WRITTEN PERMISSION IS OBTAINED FROM HAMMONDS TECHNICAL SERVICES.

HAMMONDS TECHNICAL SERVICES, INC.

SCALE: NTS APPROVED PART NUMBER: 102489 DRAWN BY: SS

DATE: 09/10/04 REVISED: 05/27/14

DRAWING TITLE: **CONTROL PANEL**

DRAWING NUMBER: 4932

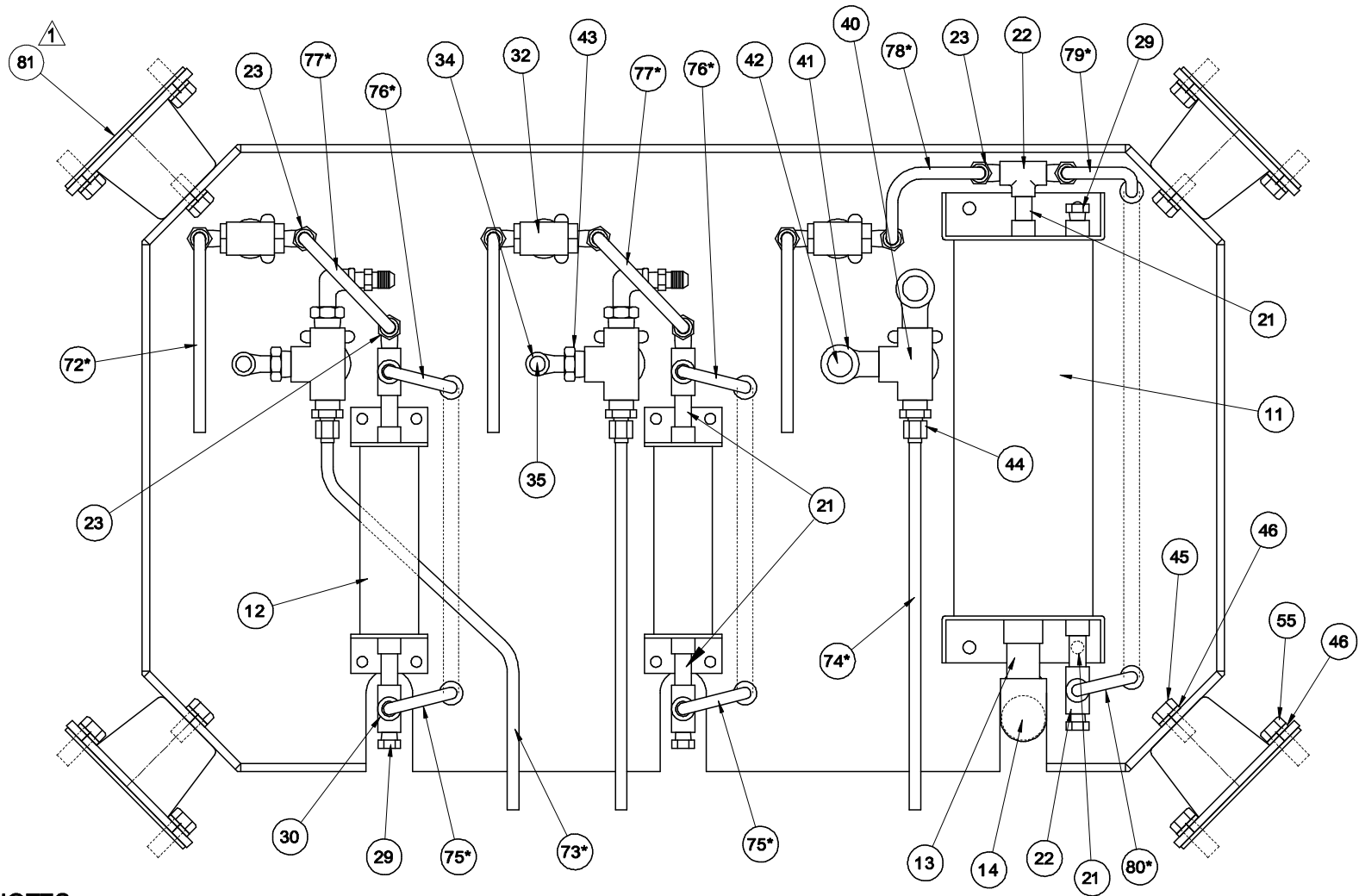

NOTES:

- 1) FOR OTHER VIEWS OF PANEL ASSEMBLY....SEE DRAWING #4932
- 2) FOR ITEMS REFERENCED SEE SEPERATE PARTS LIST

NO.	REVISION	DATE	BY	APPVD
1	ADDED ITEM 81	05/23/14	SS	X
2	INITIAL RELEASE	09/10/04	SS	X

DRAWING	LEVELS	VIEW
1839	124, 154	1

FROM SER#	DATE	TO SER#	DATE
X	X	X	X

TOLERANCES
 ALL DIMENSIONS ARE IN INCHES UNLESS OTHERWISE SPECIFIED.

*TOL. DECIMALS:
 .XXX= +/- .005
 .XX= +/- .015
 .X= +/- .030
 FRAC. = +/- 1/16

*TOL. ANGLES:
 +/- .5 DEGREES

*CONCENTRICITY:
 .005 T. I. R.

SURFACE FINISH: 125
 *REMOVE BURRS AND BREAK EDGES .005 MIN.

THIS PRINT IS CONFIDENTIAL AND IS THE PROPERTY OF HAMMONDS TECHNICAL SERVICES

THIS PRINT SHALL NOT BE USED, COPIED OR REPRODUCED IN WHOLE OR IN PART NOR SHALL THE CONTENTS BE REVEALED TO ANY PERSON TO WHOME UNLESS WRITTEN PERMISSION IS OBTAINED FROM HAMMONDS TECHNICAL SERVICES.

HAMMONDS TECHNICAL SERVICES, INC.

SCALE: NTS	APPROVED PART NUMBER: 102489	DRAWN BY: SS
DATE: 09/10/04	REVISED: 05/23/14	
DRAWING TITLE: CONTROL PANEL, REAR VIEW		
TPI-4T-4A-1		DRAWING NUMBER: 4932A

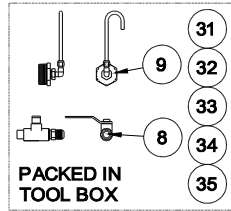
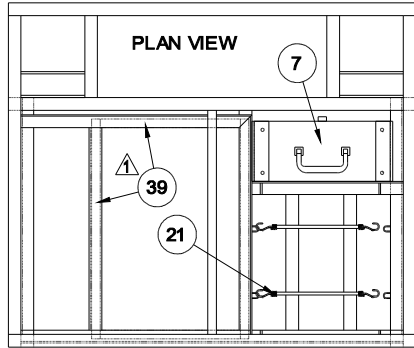

ITEM	PART NO.	QTY.	DESCRIPTION
1	882400	1	SKID, 4TP-4A
2	102515	2	TANK STRAP
3	102458L	1	CRADLE STRAP, LEFT
4	102458R	1	CRADLE STRAP, RIGHT
5	882376	1	GROUND ROD
6	882377	1	GROUND CLAMP
7	162120	1	TOOL BOX
8	102485	1	3/4" VALVE FITTING
9	102486	1	2" VENT ASS'Y.
10	882344	1	3/4" M/JIC X 3/4" MNPT ADPT, SS
11	162119	3	SNAP PIN
12	101895	3	STAINLESS CABLE, 3/64"
13	101896	6	OVAL SLEEVE, 3/64"
14	162128	1	SLEDGE HAMMER, 4 LB.....
INCLUDED IN TOOL KIT #4TP-4A TOOLS			
15	102490	4	LABEL, LIFT TIEDOWN
16	102516	1	GROUND PLATE
17	881422	10	5/16-18 X 1" HEX BOLT, SS

ITEM	PART NO.	QTY.	DESCRIPTION
18	881417	10	5/16" LOCK WASHER, SS
19	883012	4	1/2-13 X 2" HEX BOLT, SS
20	882867	4	1/2" LOCK WASHER, SS
21	882353	2	BUNGEE CORD, 24", BLACK
22	882306	4	5/16" X 1 1/4" FENDER WASHER
23	882348	1	3/4" JIC X 120" HOSE, TEFLON / SS
24	882356	1	3/4" JIC X 60" HOSE, TEFLON / SS
25	882357	1	1/2" JIC X 38" HOSE, TEFLON / SS
26	882347	1	1/2" JIC X 21" HOSE, TEFLON / SS
27	882346	1	3/8" JIC X 20" HOSE, TEFLON / SS
28	882359	2	1/4" JIC X 48" HOSE, TEFLON / SS
29	882356	4	1/4" JIC X 38" HOSE, TEFLON / SS
30	882345	2	1/4" JIC X 28" HOSE, TEFLON / SS
* 31	4TP-4A TOOLS	1	TOOL KIT, 4TP-4A
* 32	800ER KIT	1	REPAIR KIT, 800ER DRIVER
* 33	2L SS KIT	1	REPAIR KIT, 2L SS PUMP
* 34	1P7-1P7 SS KIT	1	REPAIR KIT, 1P7-1P7 SS PUMP
* 35	SFI MIL KIT	1	REPAIR KIT (1 HV/SFI & 2 SFI)
* 36	882378	1	FSII SAMPLE TEST KIT
37	102457-01	1	CRADLE PAD, 3 PC SET
38	102342	10	RUBBER GASKET, 1" x 1/8"
39	401913	88"	FOAM TAPE, 1" x .062"

* KITS PARTS LISTS ON INDIVIDUAL PAGES

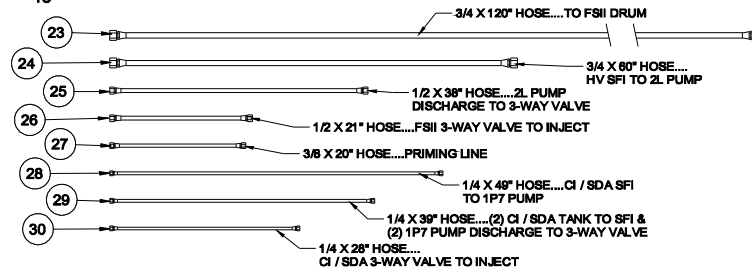
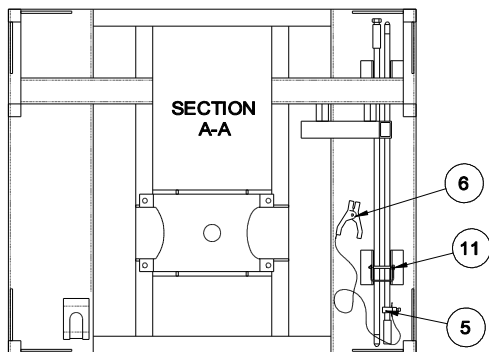
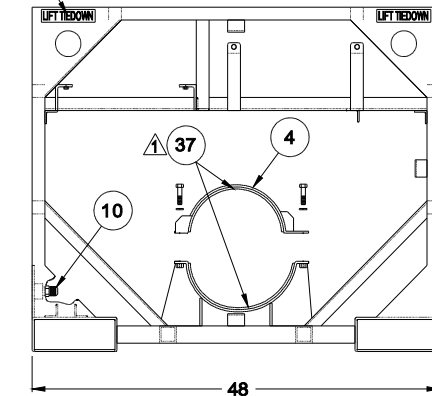
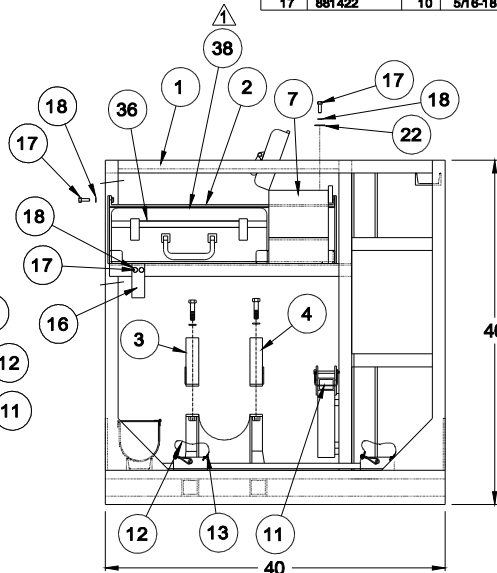
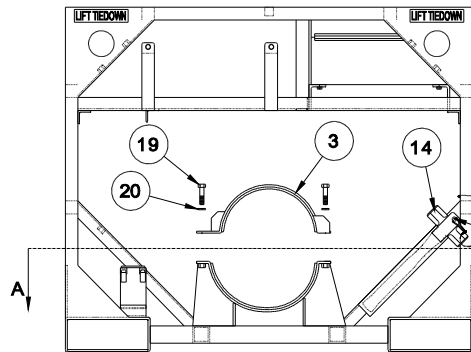

TOLERANCES
ALL DIMENSIONS ARE IN INCHES UNLESS OTHERWISE SPECIFIED.

*TOL. DECIMALS:
.XXX = +/- .005
.XX = +/- .015
.X = +/- .030
FRAC. = +/- 1/16

*TOL. ANGLES:
+/- .5 DEGREES

*CONCENTRICITY:
.005 T.I.R.

SURFACE FINISH: 125
*REMOVE BURRS AND BREAK EDGES .005 MIN.

THIS PRINT IS CONFIDENTIAL AND IS THE PROPERTY OF HAMMONDS TECHNICAL SERVICES

THIS PRINT SHALL NOT BE USED, COPIED OR REPRODUCED IN WHOLE OR IN PART IN ANY MANNER TO WHOMEVER UNLESS WRITTEN PERMISSION IS OBTAINED FROM HAMMONDS TECHNICAL SERVICES.

HAMMONDS TECHNICAL SERVICES, INC.

SCALE: NTS
DATE: 09/15/04
DRAWING TITLE: SKID SUB-ASSEMBLY

APPROVED PART NUMBER: 4TP-4A SKID
DRAWN BY: SS
REVISED: 05/23/14

MAT'L: _____ DRAWING NUMBER: 4933

NO.	REVISION	DATE	BY	APPVD
1	ADDED ITEMS 37-39	05/23/14	SS	X
2	INITIAL RELEASE	09/15/04	SS	X

DRAWING	LEVELS	VIEW
1839	68, 163-165	I

FROM SER#	DATE	TO SER#	DATE
X	X	X	X

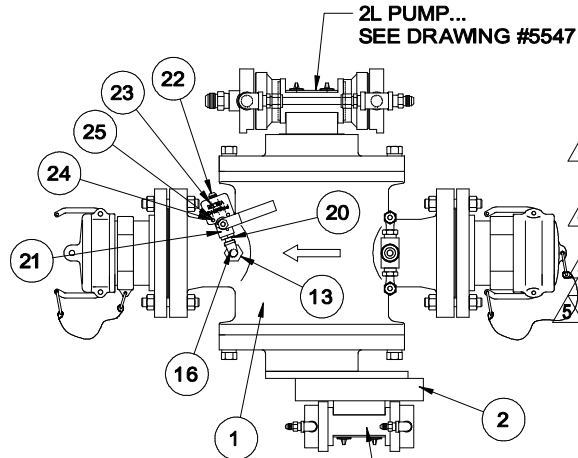

ITEM	PART NO.	QTY.	DESCRIPTION
1	807ER	1	800 DRIVER...SEE DRAWING #4864
2	883745	1	3:1 GEAR RED...SEE DWG #1694
3	271498	2	4" 150# COMP. FLANGE 4" NPT
4	881249	16	5/8-11 X 4 STUD W / NUTS
5	181001	2	4" GASKET
6	881740	2	4" X CL. PIPE NIPPLE
7	881724	1	4" FEMALE CAMLOK W / 4" FNPT, ALUM
8	881722	1	4" MALE CAMLOK W / 4" FNPT, ALUM
9	881280	1	4" DUST CAP, ALUM.
10	881725	1	4" DUST PLUG, ALUM.
11	882679	2	CHAIN 12"
12	882678	2	RING
13	271113	3	3/4" X 1/4" REDUCING BUSHING, SS
13A	271116	1	3/4" X 1/2" REDUCING BUSHING, SS
14	271090	1	1/2" X 2" PIPE NIPPLE, SS
15	271134	1	1/2" CROSS, SS
16	271125	3	1/4" 90 ST. EL, SS
17	104315	2	1/4" CHECK VALVE, SS, 5 PSI, AFLAS
17A	104325	1	1/2" CHECK VALVE, SS, 5 PSI, AFLAS
18	885352	1	1/2" M.JIC X 1/2" FNPT ADAPTER, SS
19	882360	2	1/4" M.JIC X 1/4" FNPT ADAPTER, SS
20	101069	1	1/4" X CL PIPE NIPPLE, SS

* SOME SYSTEMS INCLUDE THE FOLLOWING:
ITEM #41 REPLACES #S 3,6,8
ITEM #42 REPLACES #S 3,6,7

ITEM	PART NO.	QTY.	DESCRIPTION
21	101230	1	1/4" ON / OFF VALVE, SS
22	882339	1	3/8" MJIC X 1/4" MNPT ADAPTER, SS
23	882354	1	PRIMING VALVE TAG
24	881645	2	#10-24 X 3/8" SOC. HEAD CAP, SS
25	882949	2	#10 LW INTERNAL TOOTH, SS
26	271123	1	3/4" 90 ELBOW, SS
27	101128	2	3/4" X 3/4" MNPT TUBE ADAPTER, SS
28	102513	1	3/4" SUCTION TUBE ASS'Y, 2L SS
29	271131	1	3/4" TEE, SS
30	882344	1	3/4" MJIC X 3/4" MNPT ADAPTER, SS
31	882355	1	PUMP TAG, FSII
32	271112	4	1/2" X 1/4" REDUCING BUSHING, SS
33	271122	1	1/2" 90 ELBOW, SS
34	101141	2	1/2" X 1/2" MNPT TUBE ADAPTER, SS
35	102514	1	1/2" DISCHARGE TUBE ASS'Y, 2L SS
36	271130	1	1/2" TEE, SS
37	882343	1	1/2" MJIC X 1/2" MNPT ADAPTER, SS
38	101021	4	1/4" 90 ELBOW, SS
39	882342	4	1/4" MJIC X 1/4" MNPT ADAPTER, SS
40	882372	1	PUMP TAG, CI / SDA
*41	882713	1	4" CAMLOK ADAP x 4" 150# RF FLNG ALUM.
*42	882714	1	4" CAMLOK COUP x 4" 150# RF FLNG ALUM.
43	SEE NOTE	4	LABEL, "FLOW" PUMP HEAD
44	884156	1	SERIAL TAG, 2-3/16x3
45	401952	4	#6 DRIVE SCREW

43 PART # NOTE: LABELHA-FLOW-PMP

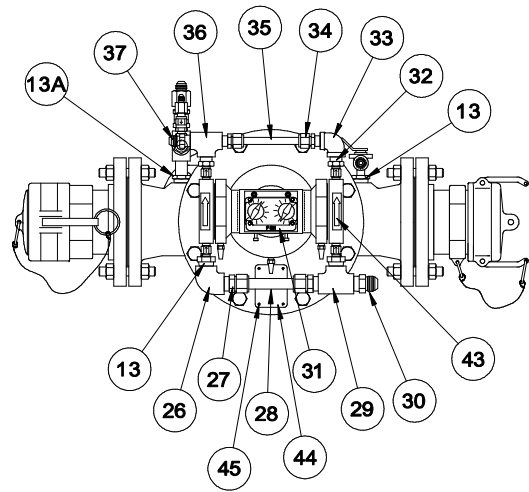
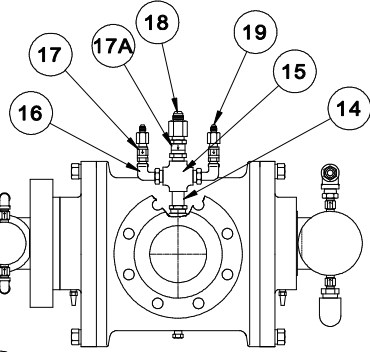
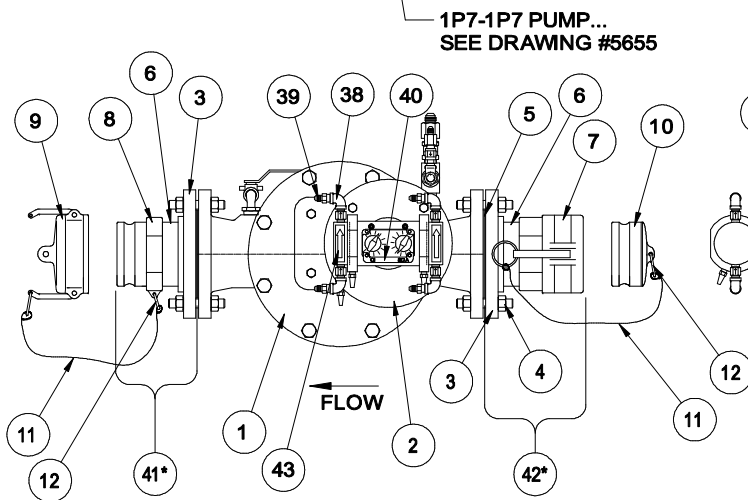

△	NEW CHECK VALVES	11/22/22	SS	JH
△	WAS 1/4" INJ CHECK VALVE, RELATED FITTINGS	10/30/17	SS	JH
△	ADDED ITEM 43-45	05/22/14	SS	CH
△	WAS 881117, 101833	05/21/14	SS	CH
△	ADDED ITEM 41, 42	08/28/08	SS	CH
NO.	REVISION	DATE	BY	APPVD

DRAWING	LEVELS	VIEW	
1839	160-162	I	
FROM SER#	DATE	TO SER#	DATE
X	X	X	X

TOLERANCES	
ALL DIMENSIONS ARE IN INCHES UNLESS OTHERWISE SPECIFIED.	
*TOL. DECIMALS: .XXX = +/- .005 .XX = +/- .015 .X = +/- .030 FRAC. = +/- 1/16	*TOL. ANGLES: +/- .5 DEGREES
*CONCENTRICITY: .005 T.I.R.	
*REMOVE BURRS AND BREAK EDGES .005 MIN.	

THIS PRINT IS CONFIDENTIAL AND IS THE PROPERTY OF HAMMONDS TECHNICAL SERVICES. THIS PRINT SHALL NOT BE USED, COPIED OR REPRODUCED IN WHOLE OR IN PART NOR SHALL THE CONTENTS BE REVEALED IN ANY MANNER TO ANYONE UNLESS WRITTEN PERMISSION IS OBTAINED FROM HAMMONDS TECHNICAL SERVICES.

HAMMONDS TECHNICAL SERVICES, INC.			
SCALE: NTS	PART NUMBER: 800ER-2L-1P7-1P7	DRAWN BY: SS	REVISED: 11/22/22
DATE: 09/13/04	DRAWING TITLE: INJECTOR SUB-ASSEMBLY		
TPI-4T-4A-1			DRAWING NUMBER: 4935

**KIT# 4TP-4A TOOLS
TOOL KIT, 4TP-4A
PARTS LIST**

Qty	Part #	Description
1	162121	MULTI-BLADE SCREWDRIVER, 7 1/2"
1	162122	HEX KEY SET, FOLDABLE
1	162123	ADJUSTABLE WRENCH, 10"
1	162124	PLIER, 10" ADJUSTABLE
1	162125	ADJUSTABLE WRENCH, 8"
1	162126	SNAP RING PLIER, .038" SMALL
1	162127	SNAP RING PLIER, .070" LARGE
1	162128	SLEDGE HAMMER, 4 LB.
1	401343	TEFLON® THREAD TAPE, 1/2" x 260"

#102489 CONTROL PANEL ASSEMBLY PARTS LIST

REFER TO DRAWINGS #4932 & 4932A

Item	Qty	Part #	Description
1	1	102471	Panel, 4T-4A
2	4	882341	Vibration Isolator
3	1	102472	¾" L-bracket
4	2	102473	¼" L-bracket
5	1	882336	5/16" U-Bolt, ss
6	2	882335	¼" U-Bolt, ss
7	2	881419	5/16-18 hex nut, ss
8	10	881417	5/16 lock washer, ss
9	4	881774	¼-20 hex nut, ss
10	4	881259	¼ lock washer, ss
11	1	102469	FSII reservoir
12	2	102470	CI/SDA reservoir
13	1	271095	¾ x 2" nipple, 304ss
14	1	271123	¾ 90 elbow, 304ss
15	1	271097	¾ x 4" nipple, 304ss
16	2	101205	¾ on/off valve, 316ss
17	3	271094	¾ x cl nipple, 304ss
18	1	271131	¾ tee, 304ss
19	2	882344	¾ mjic x ¾ mnpt adapter, ss
20	1	152020	Sight Flow Indicator, Hi-Volume, neoprene
21	6	101070	¼ x 1 ½" nipple, 304ss
22	8	101023	¼ tee, 304ss
23	10	101068	Elbow adapter, 3/8" tube x ¼ mnpt
24	14	101034	Straight adapter, 3/8" tube x ¼ mnpt
25	6	101095	Elbow adapter, ½" tube x ¼ mnpt
26	6	101685	½" tube insert
27	3	101337	112 O-ring, neoprene
28	3'	101379	½" Teflon tubing
29	4	151005	¼" hex plug, 304ss
30	2	101032	¼" cross, 304ss
31	2	271353	¼ x 2 ½" nipple, 304ss
32	7	101230	¼" on/off valve, ss
33	2	152011	Sight Flow Indicator, standard, viton®

34	9	271125	1/4" 90 st el, 304ss
35	6	882342	1/4" mjc x 1/4" mnpt adapter, ss
36	3	104315	1/4" check valve, 5 psi, Aflas
37	6	102285	Valve pointer
38	24	882949	#10 LW int. tooth, ss
39	12	881037	#10-24 x 1/2" soc. head cap, ss
40	3	101180	1/2" 3-way valve, ss
41	2	2711126	1/2" 90 st el, 304ss
42	2	882343	1/2" mjc x 1/2" mnpt adapter, ss
43	4	271112	1/2" x 1/4" red bushing, 304ss
44	3	101284	Straight adapter, 3/8" tube x 1/2" mnpt
45	4	882865	1/2-13 x 1" hex bolt, ss
46	12	882867	1/2" lock washer, ss
47	1	882333	FSII strip gauge
48	2	882334	CI/SDA strip gauge
49	15	401952	#6 x 5/16" drive screw, ss
50	4	883233	3/8-16 x 1 1/4" hex bolt, ss
51	4	881711	3/8" lock washer, ss
52	8	883344	5/16-18 x 1 1/4" hex bolt, ss
53	6	101069	1/4" x CL nipple, 304ss
54	1	101091	Female adapter, elbow 3/8" tube x 1/4" fnpt
55	8	882349	1/2-13 x 1 1/4" hex bolt, ss
56	1	882339	3/8" mjc x 1/4" mnpt adapter, ss
57	2	271127	3/4" 90° st el 304 ss
58	12	881645	#10-24 x 3/8" soc. head cap, ss
59	1	102475	Instruction Placard, 4T-4A
60	1	102476	FSII Valve Plate
61	1	102477	CI Valve Plate
62	1	102478	SDA Valve Plate
63	1	102484	NSN Data Plate
64	1	882366	FSII Valve #1 Tag
65	1	882367	FSII Valve #2 Tag
66	1	882368	CI Valve #1 Tag
67	1	882369	CI Valve #2 Tag
68	1	882370	SDA Valve #1 Tag
69	1	882371	SDA Valve #2 Tag
*70	1	102501	3/8" ss line, FSII SFI to CI SFI
*71	1	102502	3/8" ss line, CI SFI to SDA SFI
*72	3	102503	3/8" ss Vent line
*73	1	102504	3/8" ss Bleed line, SDA

*74	2	102505	3/8" ss Bleed line, FSII and CI
*75	2	102506	3/8" ss line, CI/SDA lower reservoir to gauge
*76	2	102507	3/8" ss line, CI/SDA upper reservoir to gauge
*77	2	102508	3/8" ss line, CI/SDA upper reservoir to vent
*78	1	102509	3/8" ss line, FSII upper reservoir to vent
*79	1	102510	3/8" ss line, FSII upper reservoir to gauge
*80	1	102511	3/8" ss line, FSII lower reservoir to gauge
*	1	102512	Tube Set, complete for Control Panel

* Includes all tube assemblies with * by item number.

**KIT# 800ER KIT
REPAIR KIT, 800ER DRIVER
PARTS LIST**

Qty	Part #	Description
4	101045	SNAP RING
2	103381	SNAP RING
2	103409	O-RING, VITON®
2	141036	MECHANICAL SEAL, 1"
2	881120	BEARING
4	881157	BEARING, H.D. DRIVE
2	881882	BEARING

**KIT# 2L SS KIT
REPAIR KIT, 2L SS PUMP
PARTS LIST**

Qty	Part #	Description
1	101539	LUBRIPLATE 105, 3 OZ TUBE
4	104311	CHECK VALVE, 1/4", 1 PSI, AFLAS
4	102480	O-RING, BUNA
8	282004	DIAPHRAGM ASSEMBLY, "L"
1	104325	CHECK VALVE, 1/2", 5 PSI, AFLAS

KIT# 1P7-1P7 SS KIT
REPAIR KIT, 1P7-1P7 SS PUMP
PARTS LIST

Qty	Part #	Description
8	101490	O-RING, AFLAS
1	101539	LUBRIPLATE 105, 3 OZ TUBE
4	104311	CHECK VALVE, 1/4", 1 PSI, AFLAS
4	102480	O-RING, BUNA
8	881765	OIL SEAL
2	104315	CHECK VALVE, 1/4", 5 PSI, AFLAS

KIT# SFI MIL KIT
REPAIR KIT FOR 1 HVSFI & 2 SFI
PARTS LIST

Qty	Part #	Description
2	151001	SIGHT FLOW GLASS, STANDARD
4	151007	O-RING, VITON®
1	151009	SIGHT FLOW GLASS, LARGE
2	151025	GASKET, BUNA

KIT# FSII-HTS-KIT
FSII SAMPLE TEST KIT
(Replaces #882378)
PARTS LIST

Qty	Part #	Description
1	885011	REFRACTOMETER, DIGITAL
1	885015	FUNNEL, SEPARATORY, 250 ml
1	885016	CYLINDER, GRADUATED, 250 ml
1	885017	SUPPORT RING, 3" OD
1	885018	SUPPORT BASE, 4" x 6"
1	885019	BOTTLE, 2 OZ, NARROW MOUTH
4	885020	SYRINGE, 3 ml, PP
1	885021	CARRYING CASE

(Page intentionally left blank)

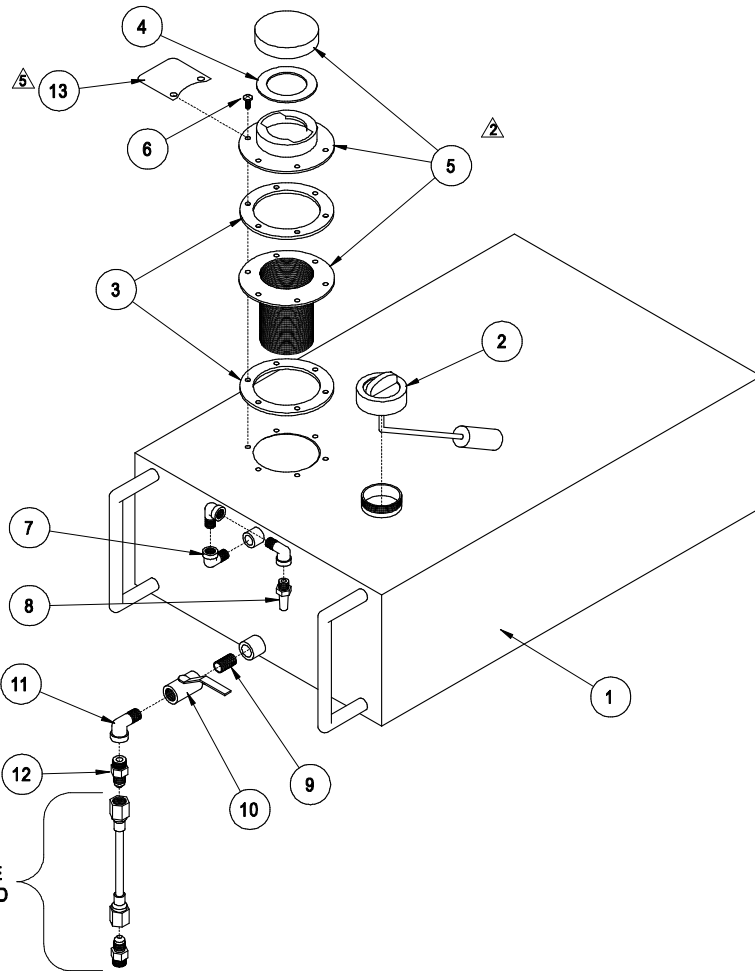

ITEM	PART NO.	QTY.	DESCRIPTION
1	102278	1	TANK SHELL, 6 GALLON
2	883189	1	LEVEL GAUGE W/PLAS CAP
	882605	1	LEVEL GAUGE W/ALUM CAP (OPT)
3	102460	2	GASKET, VITON
4	102482	1	GASKET, VITON
5	700089	1	FILLER / STRAINER
6	881223	6	SCREW, 10-32 x 1/2" PHIL
			INCLUDED W / #5
7	881714	3	1/8" ST. ELBOW
8	101749	1	1/8" VENT FILTER
6	101749-SS	1	1/8" VENT FILTER, SS (OPTION)
9	101069	1	1/4" x CL NIPPLE
10	101230	1	1/4" ON / OFF VALVE
11	271125	1	1/4" ST. ELBOW
12	882342	1	1/4" JIC ADAPTER
6	* 13	1	CI TANK TAG
	* 13	1	SDA TANK TAG

* OPTIONAL TANK TAGS

6	ADDED SS FILTER	02/17/25	SS	JH
5	ADDED TAGS	09/10/04	SS	X
4	WAS 883724 FILL	04/02/04	SS	X
3	WAS 881993...3/8"	12/12/01	SS	X
2	ADDED BAIL	11/29/01	SS	X
1	WAS 881543...PLTD	05/29/01	SS	X
NO.	REVISION	DATE	BY	APPVD

DRAWING	LEVELS	VIEW	
2813	21-23	1	
FROM SER#	DATE	TO SER#	DATE
X	X	X	X

TOLERANCES	
ALL DIMENSIONS ARE IN INCHES UNLESS OTHERWISE SPECIFIED.	
*TOL. DECIMALS:	*TOL. ANGLES:
.XXX= +/- .005	+/- .5 DEGREES
.XX= +/- .015	
.X= +/- .030	*CONCENTRICITY:
FRAC.= +/- 1/16	.005 T.I.R.
SURFACE FINISH	+REMOVE BURRS AND BREAK EDGES .005 MIN.

THIS PRINT IS CONFIDENTIAL AND IS THE PROPERTY OF HAMMONDS TECHNICAL SERVICES. THIS DRAWING SHALL NOT BE USED, COPIED OR REPRODUCED IN ANY MANNER WITHOUT WRITTEN PERMISSION BY HAMMONDS TECHNICAL SERVICES.

HAMMONDS TECHNICAL SERVICES, INC.			
SCALE	NTS	APPROVED PART NUMBER	DRAWN BY SS
DATE	06/15/00	212013	REVISED 02/17/25
DRAWING TITLE TANK ASS'Y., 6 GALLON			
MAT'L: Stainless			DRAWING NUMBER 3990A

ITEM	PART NO.	QTY.	DESCRIPTION
1	882399	1	4" HOUSING, SS
2	881724	1	4" FEMALE CAMLOK W / 4" FNPT, ALUM.
3	881722	1	4" MALE CAMLOK W / 4" FNPT, ALUM.
4	881260	1	4" DUST CAP, ALUM.
5	881725	1	4" DUST PLUG, ALUM.
6	882374	1	1/4" PROBE ASSEMBLY
7	882678	2	RING
8	882679	2	CHAIN 12"

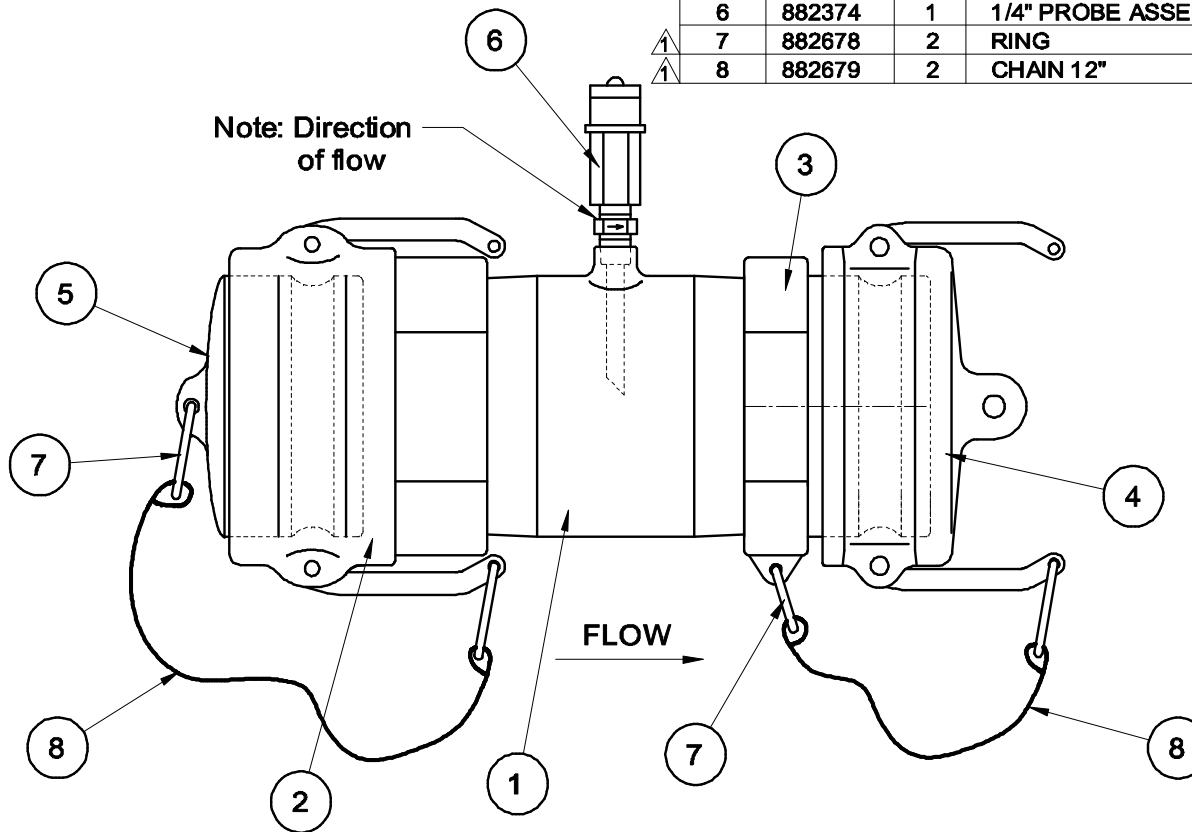

NO.	REVISION	DATE	BY	APPVD	FROM SER#	DATE	TO SER#	DATE

DRAWING	LEVELS	VIEW
1839	118, 120, 158, 159	1

TOLERANCES
ALL DIMENSIONS ARE IN INCHES UNLESS OTHERWISE SPECIFIED.

*TOL. DECIMALS:
.XXX= +/- .005
.XX= +/- .015
.X= +/- .030
FRAC. = +/- 1/16

*TOL. ANGLES:
+/- 5 DEGREES

*CONCENTRICITY:
.005 T.I.R.

BURR FREE *REMOVE BURRS AND BREAK EDGES .005 MIN.

THIS PRINT IS CONFIDENTIAL AND IS THE PROPERTY OF HAMMONDS TECHNICAL SERVICES. THIS PRINT SHALL NOT BE USED, COPIED OR REPRODUCED IN WHOLE OR IN PART NOR SHALL THE CONTENTS BE RELEASED IN ANY MANNER TO ANYONE UNLESS WRITTEN PERMISSION IS OBTAINED FROM HAMMONDS TECHNICAL SERVICES.

HAMMONDS TECHNICAL SERVICES, INC.			
SCALE	NTS	APPROVED PART NUMBER	102491
DATE	03/02/04	DRAWN BY	SS
DRAWING TITLE		REVISED	05/23/14
4" SAMPLE PROBE			
TPI-4T-4A			DRAWING NUMBER 4934

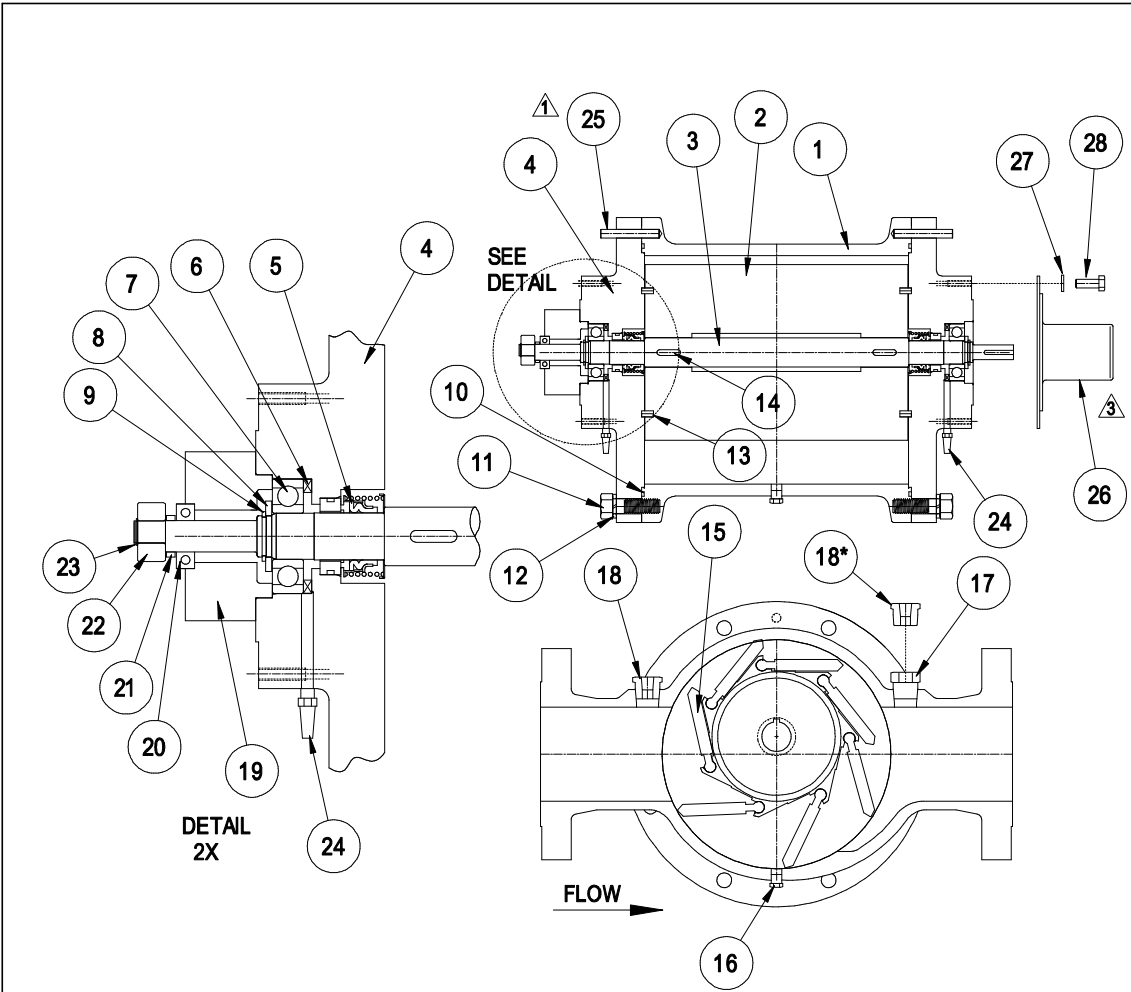

ITEM	PART NO.	QTY.	DESCRIPTION
1	184038	1	HOUSING, ALUMINUM
2	184186	1	ROTOR, 7 VANE
3	184081	1	SHAFT, ER (SINGLE ECC.)
4	184093	2	END PLATE
5	141036	2	MECHANICAL SEAL, STD.
	141023	2	MECHANICAL SEAL, HP (OPT)
6	103383	2	WAVE SPRING WASHER
7	881623	2	BEARING
8	184004	2	THRUST WASHER
9	103381	2	SNAP RING
10	103409	2	O-RING, VITON
11	881621	16	BOLT, 5/8-11 x 2"
	886319	16	BOLT, 5/8-11 x 2", SS
12	882076	16	LOCK WASHER, 5/8"
	886325	16	LOCK WASHER, 5/8", SS
13	184167	2	WEAR RING
14	184081-01	2	KEY, 1/4" SQ. x 1"
15	184011	7	VANE, TEFLON
16	151005	1	1/4" PIPE PLUG
17*	271249	1	3/4" PIPE PLUG
18*	271113	1	3/4 x 1/4 RED. BUSHING
19	184037	1	BEARING CAP
20	881882	1	BEARING
21	881999	1	SPACER
22	881157	1	H.D. DRIVE BEARING
23	101045	1	SNAP RING
24	101749	2	1/8" FILTER (OPTIONAL)
	101749-SS	2	1/8" FILTER, SS (OPTIONAL)
25	882215	2	PIN, DOWEL
26	882125	1	SHAFT COVER (OPT)
27	881083	4	3/8" LOCKWASHER (OPT)
	881711	4	3/8" LOCKWASHER, SS (OPT)
28	881084	4	3/8 x 1" HEX BOLT (OPT)
	881709	4	3/8 x 1" HEX BOLT, SS (OPT)

* OPTION...
 IF ITEM #18 QTY IS 2, THEN ITEM #17 QTY IS 0

NO.	REVISION	DATE	BY	APPVD
1	ADDED SS HARDWARE	10/03/22	SS	JH
2	ADDED SHAFT COVER	07/26/16	SS	X
3	ADDED OPTION NOTE	05/21/14	SS	X
4	ADDED DOWEL PIN	12/28/11	SS	X
5	INITIAL RELEASE	05/20/04	SS	X

DRAWING	LEVELS	VIEW
800DRVR	250, 251	1

FROM SER#	DATE	TO SER#	DATE
X	X	X	X

TOLERANCES
 ALL DIMENSIONS ARE IN INCHES UNLESS OTHERWISE SPECIFIED.

*TOL. DECIMALS:
 .XXX= +/- .005
 .XX= +/- .015
 .X= +/- .030
 FRAC.= +/- 1/16

*TOL. ANGLES:
 +/- .5 DEGREES

*CONCENTRICITY:
 .005 I. I. R.

*REMOVE BURRS AND BREAK EDGES .005 MIN.

THIS PRINT IS CONFIDENTIAL AND IS THE PROPERTY OF HAMMONDS TECHNICAL SERVICES

THIS PRINT SHALL NOT BE USED, COPIED OR REPRODUCED IN WHOLE OR IN PART NOR SHALL THE CONTENTS BE RELEASED IN ANY MANNER TO ANYONE UNLESS WRITTEN PERMISSION IS OBTAINED FROM HAMMONDS TECHNICAL SERVICES.

HAMMONDS TECHNICAL SERVICES, INC.

SCALE: NTS APPROVED: PART NUMBER: 807ER DRAWN BY: SS

DATE: 05/20/04 REVISED: 10/03/22

DRAWING TITLE: **MODEL 800ER DRIVER (ALUM)**

7 VANE ROTOR DRAWING NUMBER: **4864**

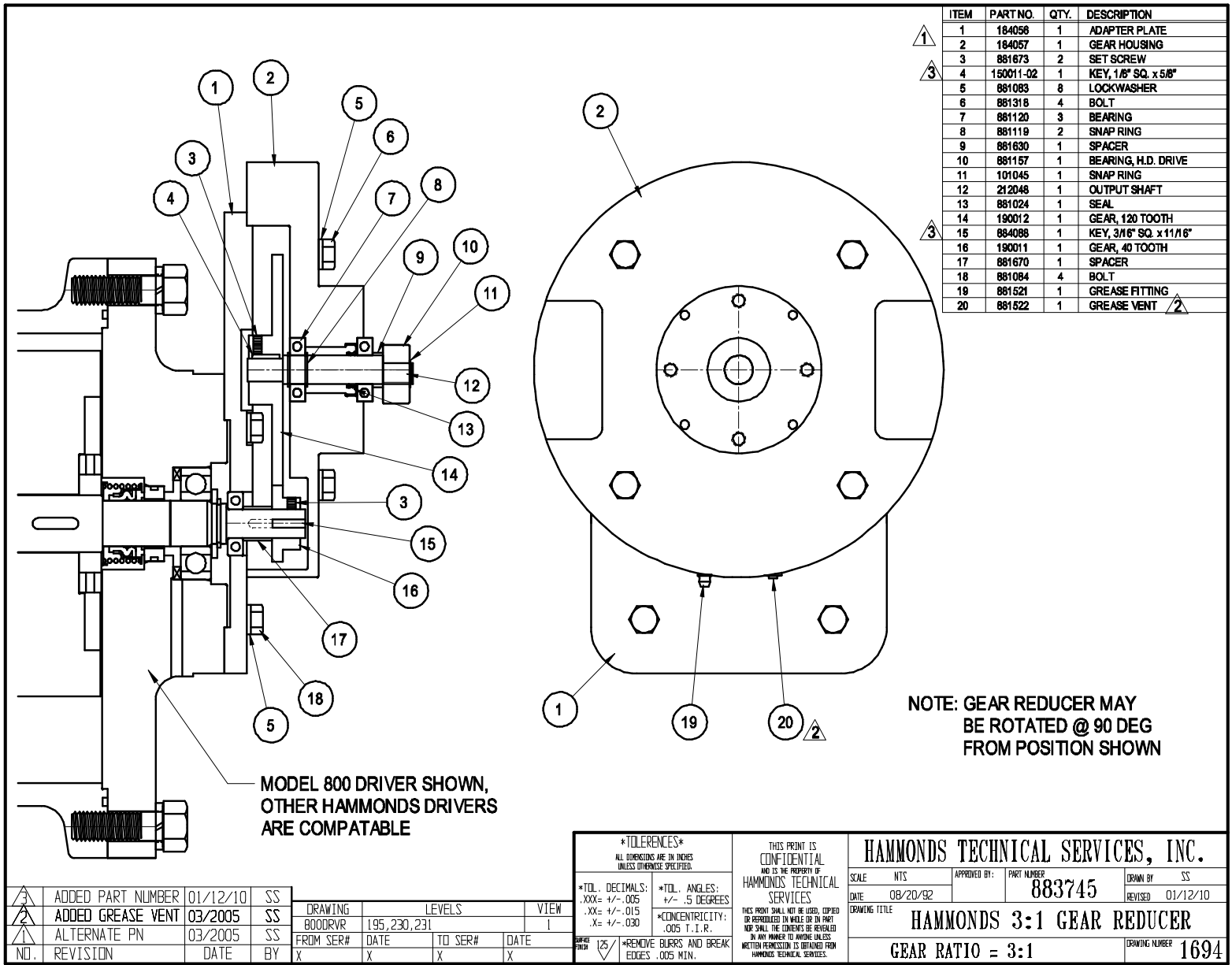

ITEM	PART NO.	QTY.	DESCRIPTION
1	184058	1	ADAPTER PLATE
2	184057	1	GEAR HOUSING
3	881673	2	SET SCREW
4	150011-02	1	KEY, 1/8" SQ. x 5/8"
5	881083	8	LOCKWASHER
6	881318	4	BOLT
7	881120	3	BEARING
8	881119	2	SNAP RING
9	881630	1	SPACER
10	881157	1	BEARING, H.D. DRIVE
11	101045	1	SNAP RING
12	212048	1	OUTPUT SHAFT
13	881024	1	SEAL
14	190012	1	GEAR, 120 TOOTH
15	884088	1	KEY, 3/16" SQ. x 11/16"
16	190011	1	GEAR, 40 TOOTH
17	881670	1	SPACER
18	881084	4	BOLT
19	881521	1	GREASE FITTING
20	881522	1	GREASE VENT

NOTE: GEAR REDUCER MAY BE ROTATED @ 90 DEG FROM POSITION SHOWN

MODEL 800 DRIVER SHOWN, OTHER HAMMONDS DRIVERS ARE COMPATABLE

ADD PART NUMBER	01/12/10	SS	DRAWING	LEVELS	VIEW
ADDED GREASE VENT	03/2005	SS	B00DRVR	195, 230, 231	1
ALTERNATE PN	03/2005	SS	FROM SER#	DATE	TO SER#
NO.	REVISION	DATE	BY	X	X

<p>*TOLERANCES*</p> <p>ALL DIMENSIONS ARE IN INCHES UNLESS OTHERWISE SPECIFIED.</p>		<p>THIS PRINT IS CONFIDENTIAL AND IS THE PROPERTY OF HAMMONDS TECHNICAL SERVICES</p>		<p>HAMMONDS TECHNICAL SERVICES, INC.</p>	
<p>*TOL. DECIMALS:</p> <p>.XXX= +/- .005</p> <p>.XX= +/- .015</p> <p>.X= +/- .030</p>	<p>*TOL. ANGLES:</p> <p>+/- .5 DEGREES</p>	<p>*CONCENTRICITY:</p> <p>.005 T. I. R.</p>	<p>SCALE NTS</p>	<p>APPROVED BY:</p>	<p>PART NUMBER</p> <p>883745</p>
<p>THIS PRINT SHALL NOT BE USED, COPIED OR REPRODUCED IN WHOLE OR IN PART NOR SHALL THE CONTENTS BE REVEALED IN ANY MANNER TO ANYONE UNLESS WRITTEN PERMISSION IS OBTAINED FROM HAMMONDS TECHNICAL SERVICES.</p>			<p>DATE</p> <p>08/20/92</p>	<p>DRAWN BY</p> <p>SS</p>	<p>REVISED</p> <p>01/12/10</p>
<p>REMOVE BURRS AND BREAK EDGES .005 MIN.</p>			<p>DRAWING TITLE</p> <p>HAMMONDS 3:1 GEAR REDUCER</p>		
<p>GEAR RATIO = 3:1</p>			<p>DRAWING NUMBER</p> <p>1694</p>		

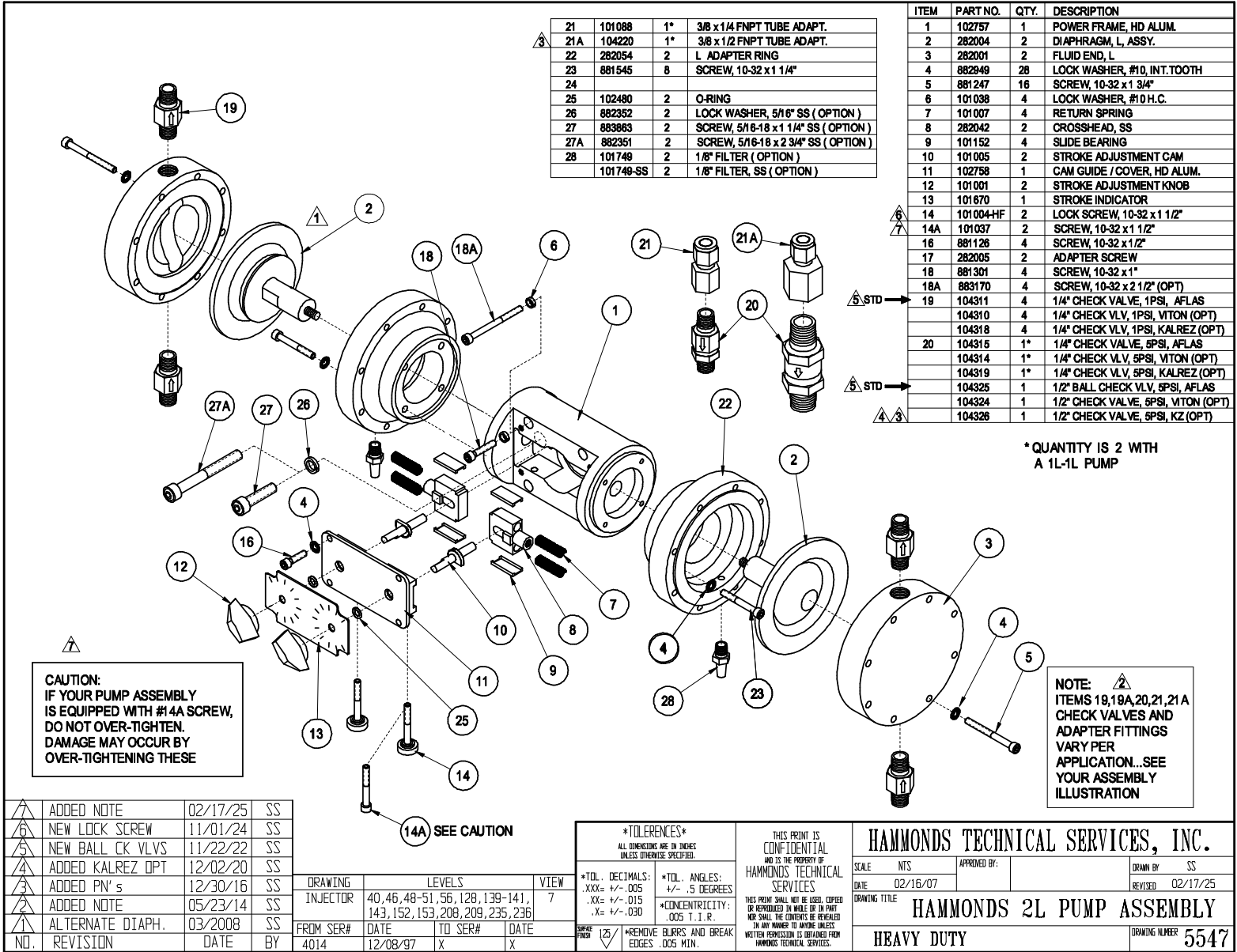

21	101088	1*	3/8 x 1/4 FNPT TUBE ADAPT.
21A	104220	1*	3/8 x 1/2 FNPT TUBE ADAPT.
22	282054	2	L ADAPTER RING
23	881545	8	SCREW, 10-32 x 1 1/4"
24			
25	102480	2	O-RING
26	882352	2	LOCK WASHER, 5/16" SS (OPTION)
27	883963	2	SCREW, 5/16-18 x 1 1/4" SS (OPTION)
27A	882351	2	SCREW, 5/16-18 x 2 3/4" SS (OPTION)
28	101749	2	1/8" FILTER (OPTION)
101749-SS		2	1/8" FILTER, SS (OPTION)

ITEM	PART NO.	QTY.	DESCRIPTION
1	102757	1	POWER FRAME, HD ALUM.
2	282004	2	DIAPHRAGM, L, ASSY.
3	282001	2	FLUID END, L
4	882949	28	LOCK WASHER, #10, INT. TOOTH
5	881247	16	SCREW, 10-32 x 1 3/4"
6	101038	4	LOCK WASHER, #10 H.C.
7	101007	4	RETURN SPRING
8	282042	2	CROSSHEAD, SS
9	101152	4	SLIDE BEARING
10	101005	2	STROKE ADJUSTMENT CAM
11	102758	1	CAM GUIDE / COVER, HD ALUM.
12	101001	2	STROKE ADJUSTMENT KNOB
13	101670	1	STROKE INDICATOR
14	101004-HF	2	LOCK SCREW, 10-32 x 1 1/2"
14A	101037	2	SCREW, 10-32 x 1 1/2"
16	881126	4	SCREW, 10-32 x 1 1/2"
17	282005	2	ADAPTER SCREW
18	881301	4	SCREW, 10-32 x 1"
18A	883170	4	SCREW, 10-32 x 2 1/2" (OPT)
19	104311	4	1/4" CHECK VALVE, 1PSI, AFLAS
	104310	4	1/4" CHECK VLV, 1PSI, VITON (OPT)
	104318	4	1/4" CHECK VLV, 1PSI, KALREZ (OPT)
20	104315	1*	1/4" CHECK VALVE, 6PSI, AFLAS
	104314	1*	1/4" CHECK VLV, 6PSI, VITON (OPT)
	104319	1*	1/4" CHECK VLV, 6PSI, KALREZ (OPT)
	104325	1	1/2" BALL CHECK VLV, 6PSI, AFLAS
	104324	1	1/2" CHECK VALVE, 6PSI, VITON (OPT)
	104326	1	1/2" CHECK VALVE, 6PSI, KZ (OPT)

* QUANTITY IS 2 WITH A 1L-1L PUMP

CAUTION:
IF YOUR PUMP ASSEMBLY IS EQUIPPED WITH #14A SCREW, DO NOT OVER-TIGHTEN. DAMAGE MAY OCCUR BY OVER-TIGHTENING THESE

NOTE:
ITEMS 19, 19A, 20, 21, 21 A CHECK VALVES AND ADAPTER FITTINGS VARY PER APPLICATION...SEE YOUR ASSEMBLY ILLUSTRATION

△	ADDED NOTE	02/17/25	SS
△	NEW LOCK SCREW	11/01/24	SS
△	NEW BALL CK VLVS	11/22/22	SS
△	ADDED KALREZ OPT	12/02/20	SS
△	ADDED PN's	12/30/16	SS
△	ADDED NOTE	05/23/14	SS
△	ALTERNATE DIAPH.	03/2008	SS
NO.	REVISION	DATE	BY

DRAWING		LEVELS		VIEW
INJECTOR	40, 46, 48-51, 56, 128, 139-141, 143, 152, 153, 208, 209, 235, 236			7
FROM SER#	DATE	TO SER#	DATE	
4014	12/08/97	X	X	

TOLERANCES	
ALL DIMENSIONS ARE IN INCHES UNLESS OTHERWISE SPECIFIED.	
*TOL. DECIMALS:	*TOL. ANGLES:
.XXX= +/- .005	+/- .5 DEGREES
.XX= +/- .015	
.X= +/- .030	*CONCENTRICITY:
	.005 T. I. R.
*REMOVE FILLS AND BREAK EDGES .005 MIN.	

THIS PRINT IS CONFIDENTIAL AND IS THE PROPERTY OF HAMMONDS TECHNICAL SERVICES
THIS PRINT SHALL NOT BE LOANED, COPIED OR REPRODUCED IN WHOLE OR IN PART IN ANY MANNER TO AVOID UNLESS WRITTEN PERMISSION IS OBTAINED FROM HAMMONDS TECHNICAL SERVICES.

HAMMONDS TECHNICAL SERVICES, INC.

SCALE: NTS APPROVED BY: _____ DRAWN BY: SS

DATE: 02/16/07 REVISED: 02/17/25

DRAWING TITLE: **HAMMONDS 2L PUMP ASSEMBLY**

HEAVY DUTY DRAWING NUMBER: **5547**

NOTE: MARK STROKE SETTING BEFORE REMOVING ANY PART

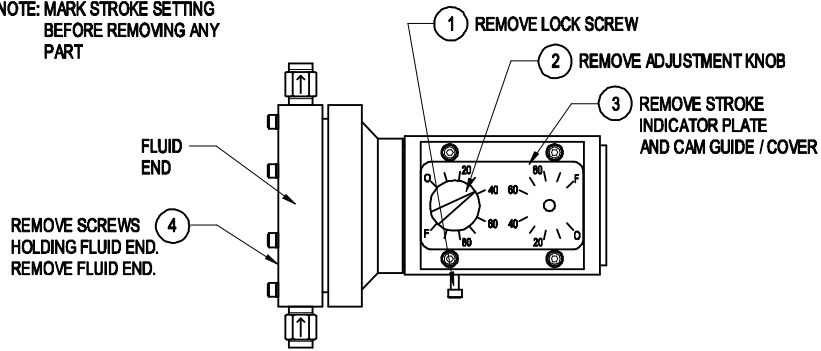

1

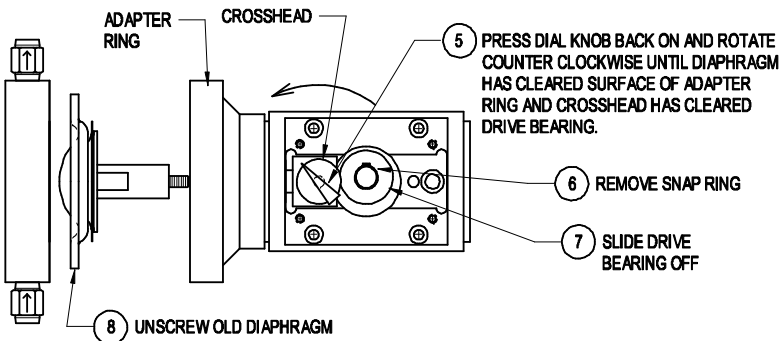

2

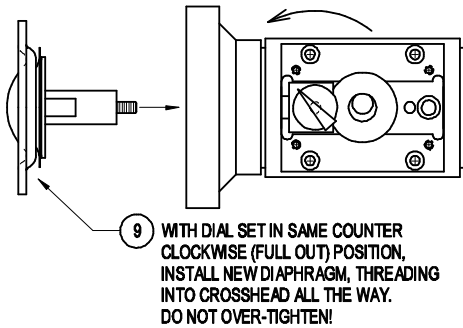

3

*WARNING... FAILURE TO TORQUE SCREWS PROPERLY TO 40 IN. LBS. WILL REDUCE PUMP HEAD PERFORMANCE, RESULTING IN INSUFFICIENT INJECTION RATIO.

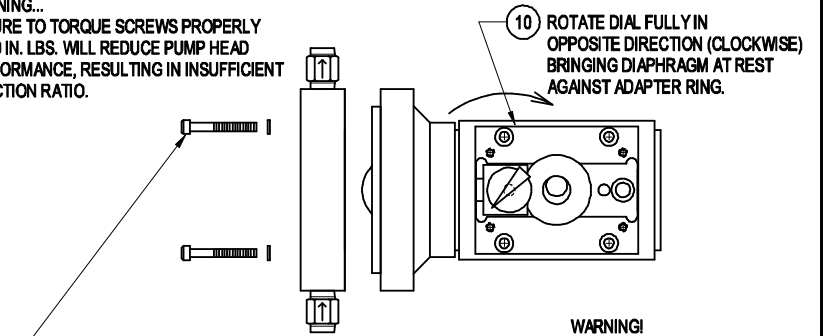

4

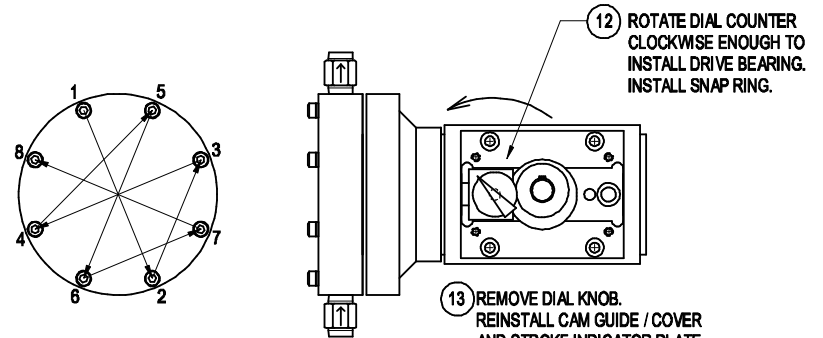

5

NOTE: AFTER THIS PROCEDURE IS COMPLETE, YOU MUST RECALIBRATE THE INJECTOR TO YOUR SPECIFICATIONS.

FOR TECHNICAL ASSISTANCE CALL HAMMONDS TECH. SVS. (281) 999-2900

HAMMONDS TECHNICAL SERVICES, INC.

SCALE	NTS	APPROVED	PART NUMBER	DRAWN BY	SS
DATE	10/03/1997			REVISED	-

DRAWING TITLE "L" DIAPHRAGM REPLACEMENT

DRAWING	LEVELS	VIEW
1461	5, 6	1

HEAVY DUTY PUMP SERIES

DRAWING NUMBER 1461-1

26	882352	2	LOCK WASHER, 5/16" SS (OPT)
27	883863	2	SCREW, 5/16-18 x 1 1/4" SS (OPT)
27A	882351	2	SCREW, 5/16-18 x 2 3/4" SS (OPT)
28	102480	2	O-RING (OPTION)

ITEM	PART NO.	QTY.	DESCRIPTION
1	102757	1	POWER FRAME, HD ALUM.
2			
3	102192	2	PLUNGER ASSY, P7
4	881785	2	SEAL, LIP
5	101748	2	1/8" FILTER (OPTION)
	101748-SS	2	1/8" FILTER, SS (OPTION)
6	102194	2	SEAL ADAPTER
6A	102474	2	SEAL ADAPTER, VENTED (OPT)
7	101490	2	O-RING, AFLAS, STD
	101226	2	O-RING, VITON (OPTION)
	101754	2	O-RING, KALREZ (OPTION)
8	102193	2	FLUID END, P7
9	882949	12	LOCK WASHER, #10 INTERNAL
10	881317	8	SCREW, #10-32 x 2"
11	104311	4	CHECK VALVE, 1PSI, AFLAS
	104310	4	CHECK VALVE, 1PSI, VITON (OPT)
	104318	4	CHECK VALVE, 1PSI, KALREZ (OPT)
12	101007	4	RETURN SPRING
13	101008	2	CROSSHEAD
14	101152	4	SLIDE BEARING
15	101005	2	STROKE ADJUSTMENT CAM
16	102758	1	CAM GUIDE / COVER, HD ALUM.
17	101670	1	STROKE INDICATOR
18	101004-HF	2	LOCKSCREW, #10-32 x 1 1/2"
18A	101037	2	SCREW, #10-32 x 1 1/2"
19	881128	4	SCREW, #10-32 x 1 1/2"
20	101001	2	STROKE ADJUSTMENT KNOB
21			
22	881301	4	SCREW, #10-32 x 1"
22A	883170	4	SCREW, #10-32 x 2 1/2" (OPT)
23	101038	4	LOCK WASHER, #10 H.C.
24	104315	1*	CHECK VALVE, 5 PSI, AFLAS
	104314	1*	CHECK VALVE, 5 PSI, VITON (OPT)
	104319	1*	CHECK VALVE, 5 PSI, KALREZ (OPT)
25	101088	1*	3/8 x 1/4 FNPT TUBE ADAPT.

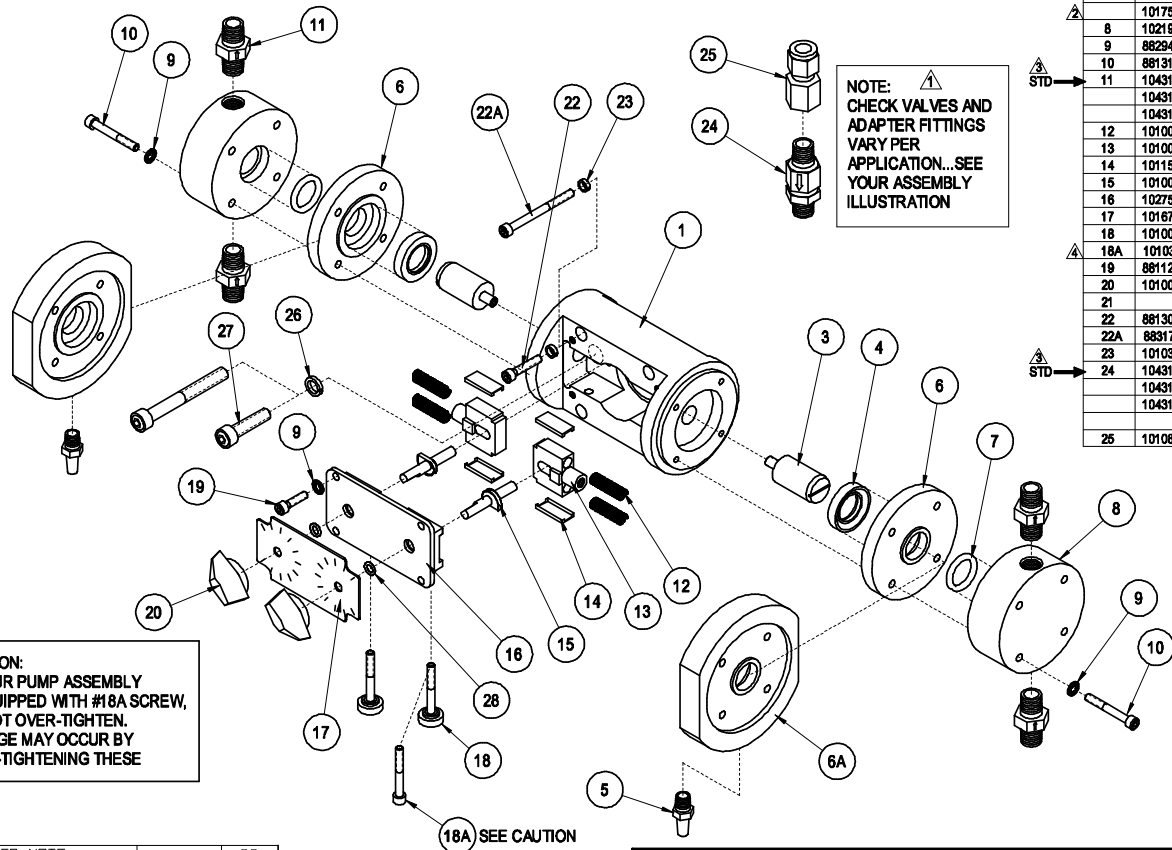

* QUANTITY IS 2 WITH A 1P7-1P7 PUMP

CAUTION:
IF YOUR PUMP ASSEMBLY IS EQUIPPED WITH #18A SCREW, DO NOT OVER-TIGHTEN. DAMAGE MAY OCCUR BY OVER-TIGHTENING THESE

ADD NOTE	02/17/25	SS
NEW BALL CK VLV	05/03/23	SS
ADDED PART NOS.	03/08/18	SS
PLNGR ASSY W/SCR AND ADDED NOTE	05/22/14	SS
INITIAL RELEASE	08/13/07	SS
NO. REVISION	DATE	BY

DRAWING	LEVELS	VIEW	
INJECTOR	104, 90-93, 95-97, 100-102, 104-107, 136, 139-141, 143, 153, 208, 210, 211, 244	1	
FROM SER#	DATE	TO SER#	DATE
X	X	X	X

TOLERANCES
ALL DIMENSIONS ARE IN INCHES UNLESS OTHERWISE SPECIFIED.

*TOL. DECIMALS:
.XXX = +/- .005
.XX = +/- .015
.X = +/- .030
FRAC. = +/- 1/16

*TOL. ANGLES:
+/- .5 DEGREES

*CONCENTRICITY:
.005 T.I.R.

REMOVE BURRS AND BREAK EDGES .005 MIN.

THIS PRINT IS CONFIDENTIAL AND IS THE PROPERTY OF HAMMONDS TECHNICAL SERVICES

THIS PRINT SHALL NOT BE USED, COPIED OR REPRODUCED IN WHOLE OR IN PART, NOR SHALL THE CONTENTS BE REVEALED IN ANY MANNER TO AVOID UNLESS WRITTEN PERMISSION IS OBTAINED FROM HAMMONDS TECHNICAL SERVICES.

HAMMONDS TECHNICAL SERVICES, INC.

SCALE: **NTS** APPROVED PART NUMBER: _____ DRAWN BY: **SS**

DATE: **08/13/07** REVISION: **02/17/25**

DRAWING TITLE: **HAMMONDS 2P7 (1P7-1P7) PUMP**

HEAVY DUTY DRAWING NUMBER: **5655**

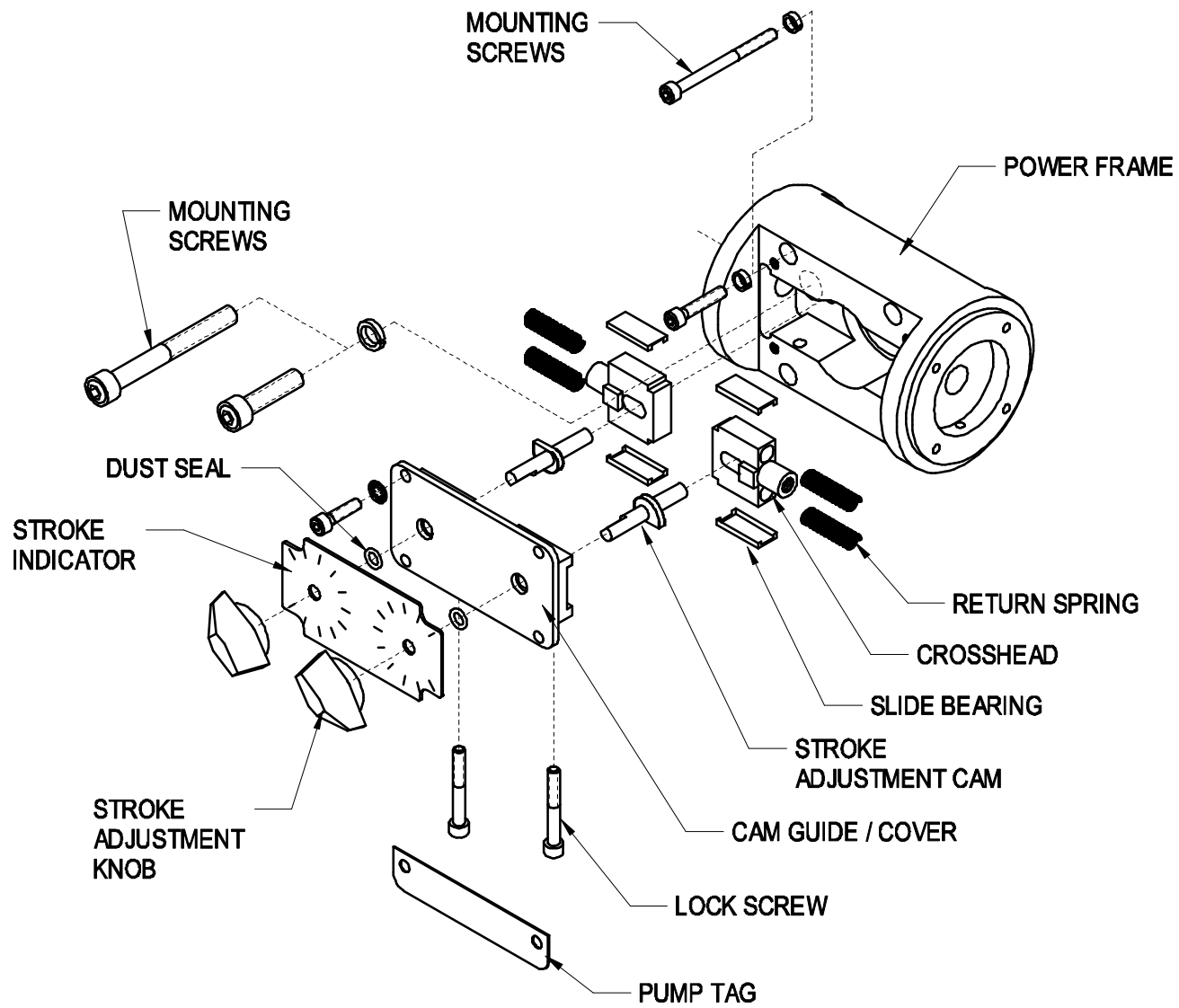

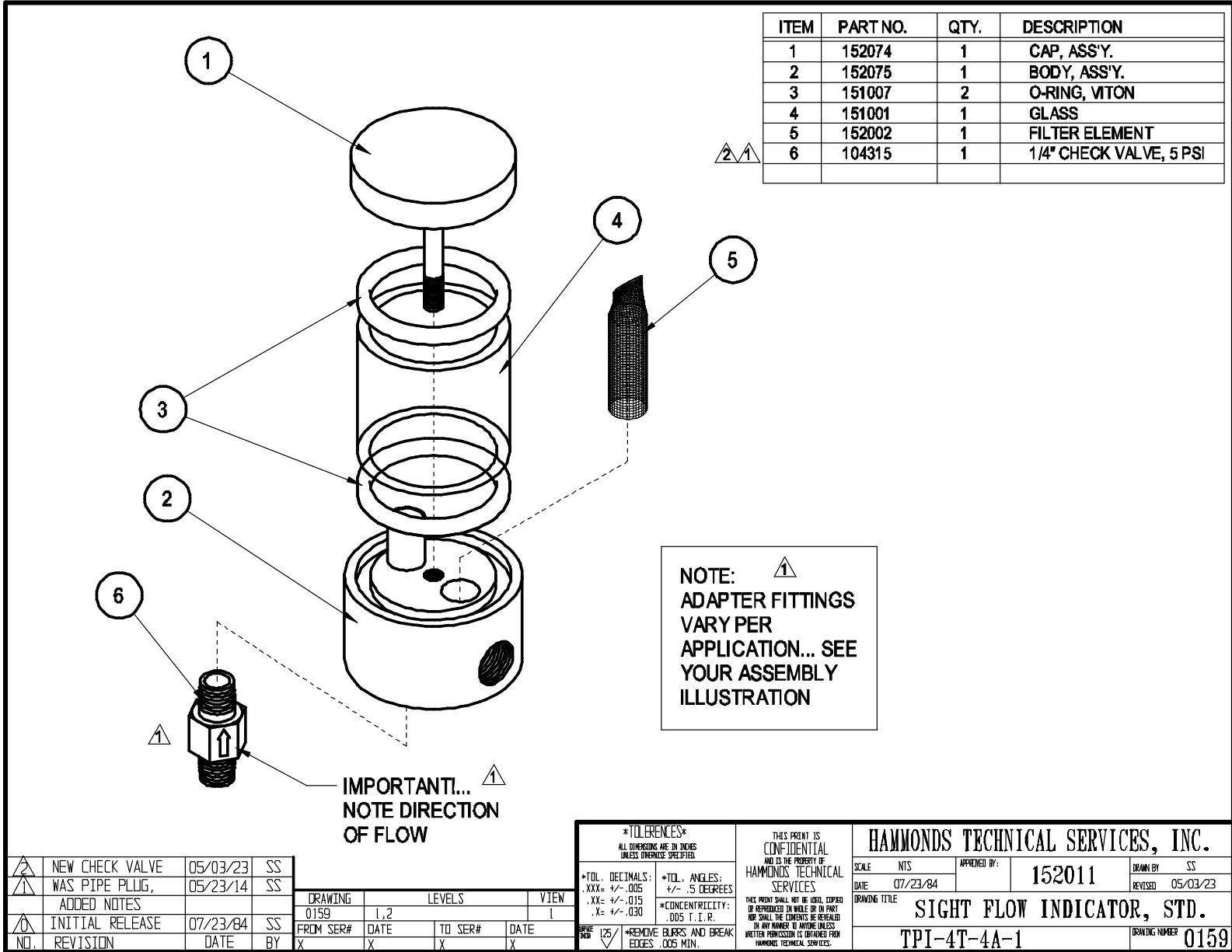



ITEM	PART NO.	QTY.	DESCRIPTION
1	152074	1	CAP, ASS'Y.
2	152075	1	BODY, ASS'Y.
3	151007	2	O-RING, VITON
4	151001	1	GLASS
5	152002	1	FILTER ELEMENT
6	104315	1	1/4" CHECK VALVE, 5 PSI

NOTE: 
 ADAPTER FITTINGS
 VARY PER
 APPLICATION... SEE
 YOUR ASSEMBLY
 ILLUSTRATION

IMPORTANT!... 
 NOTE DIRECTION
 OF FLOW

	NEW CHECK VALVE	05/03/23	SS
	WAS PIPE PLUG,	05/23/14	SS
	ADDED NOTES		
	INITIAL RELEASE	07/23/84	SS
NO.	REVISION	DATE	BY

DRAWING	LEVELS	VIEW
0159	1,2	I
FROM SER#	DATE	TO SER#
X	X	X

TOLERANCES
 ALL DIMENSIONS ARE IN INCHES
 UNLESS OTHERWISE SPECIFIED.

*TOL. DECIMALS:	*TOL. ANGLES:
.XXX= +/- .005	+/- .5 DEGREES
.XX= +/- .015	
.X= +/- .030	
*CONCENTRICITY:	
.005 T. I. R.	

REMOVE BLURS AND BREAK EDGES .005 MIN.

THIS PRINT IS
 CONFIDENTIAL
 AND IS THE PROPERTY OF
 HAMMONDS TECHNICAL
 SERVICES

THIS PRINT SHALL NOT BE USED, COPIED
 OR REPRODUCED IN WHOLE OR IN PART
 NOR SHALL THE CONTENTS BE REVEALED
 IN ANY MANNER TO ANYONE UNLESS
 WRITTEN PERMISSION IS OBTAINED FROM
 HAMMONDS TECHNICAL SERVICES.

HAMMONDS TECHNICAL SERVICES, INC.			
SCALE	NTS	APPROVED BY:	SS
DATE	07/23/84	152011	REVISION
DRAWING TITLE		05/03/23	
SIGHT FLOW INDICATOR, STD.			
TPI-4T-4A-1			DRAWING NUMBER
			0159

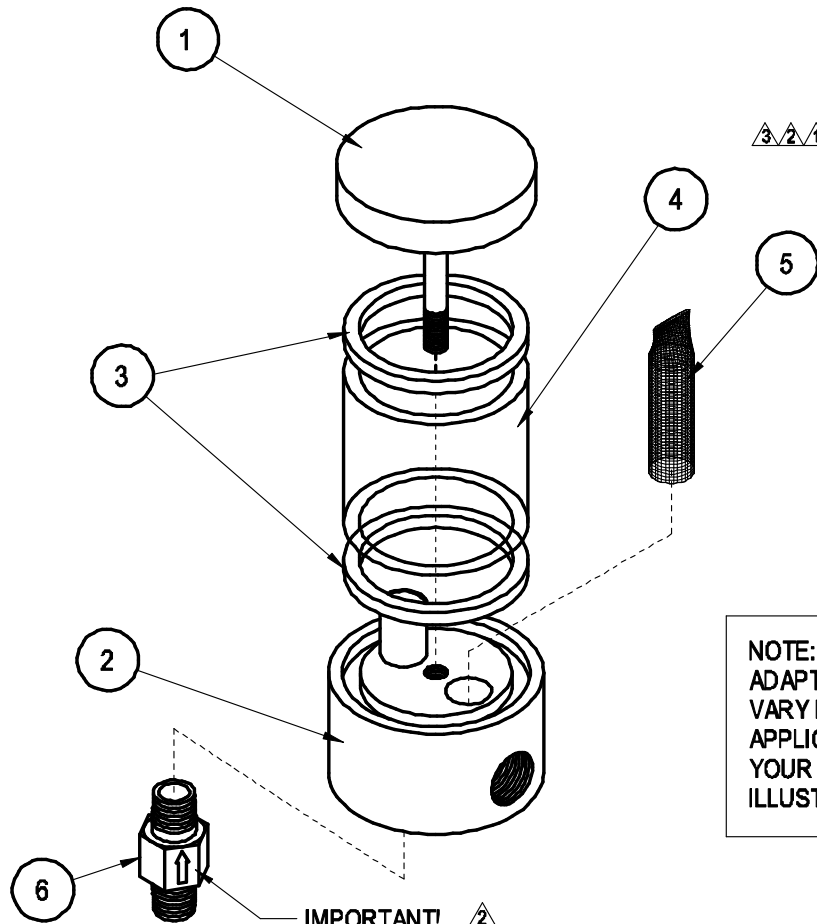

ITEM	PART NO.	QTY.	DESCRIPTION
1	152081	1	CAP
2	152080	1	BODY
3	151025	2	GASKET, BUNA-N
4	151009	1	GLASS
5	152025	1	FILTER ELEMENT
6	104315	1	1/4" CK VL.V, 5 PSI, AFLAS

3, 2, 1

NOTE: ADAPTER FITTINGS VARY PER APPLICATION... SEE YOUR ASSEMBLY ILLUSTRATION

IMPORTANT!... NOTE DIRECTION OF FLOW

	NEW CHECK VALVE	05/03/23	SS	JH
	WAS PIPE PLUG, ADDED NOTES	05/23/14	SS	JH
	ADDED PLUG	03/24/10	SS	X
NO.	REVISION	DATE	BY	APPVD

DRAWING	LEVELS	VIEW
1349	1,2	I

FROM SER#	DATE	TO SER#	DATE
X	X	X	X

TOLERANCES
ALL DIMENSIONS ARE IN INCHES UNLESS OTHERWISE SPECIFIED.

*TOL. DECIMALS:
.XXX = +/- .005
.XX = +/- .015
.X = +/- .030
FRAC. = +/- 1/16

*TOL. ANGLES:
1/2 = .5 DEGREES

*CONCENTRICITY:
.005 T. I. R.

REMOVE BURRS AND BREAK EDGES .005 MIN.

THIS PRINT IS CONFIDENTIAL AND IS THE PROPERTY OF HAMMONDS TECHNICAL SERVICES

THIS PRINT SHALL NOT BE LOANED, COPIED OR REPRODUCED IN WHOLE OR IN PART NOR SHALL THE CONTENTS BE REVEALED IN ANY MANNER TO ANYONE UNLESS WRITTEN PERMISSION IS OBTAINED FROM HAMMONDS TECHNICAL SERVICES.

HAMMONDS TECHNICAL SERVICES, INC.			
SCALE: NTS	APPROVED PART NUMBER: 152020	DRAWN BY: SSS	REVISED: 05/03/23
DATE: 10/21/91	DRAWING TITLE: HI-VOL SIGHT FLOW INDICATOR		
TPI-4T-4A-1			DRAWING NUMBER: 1349

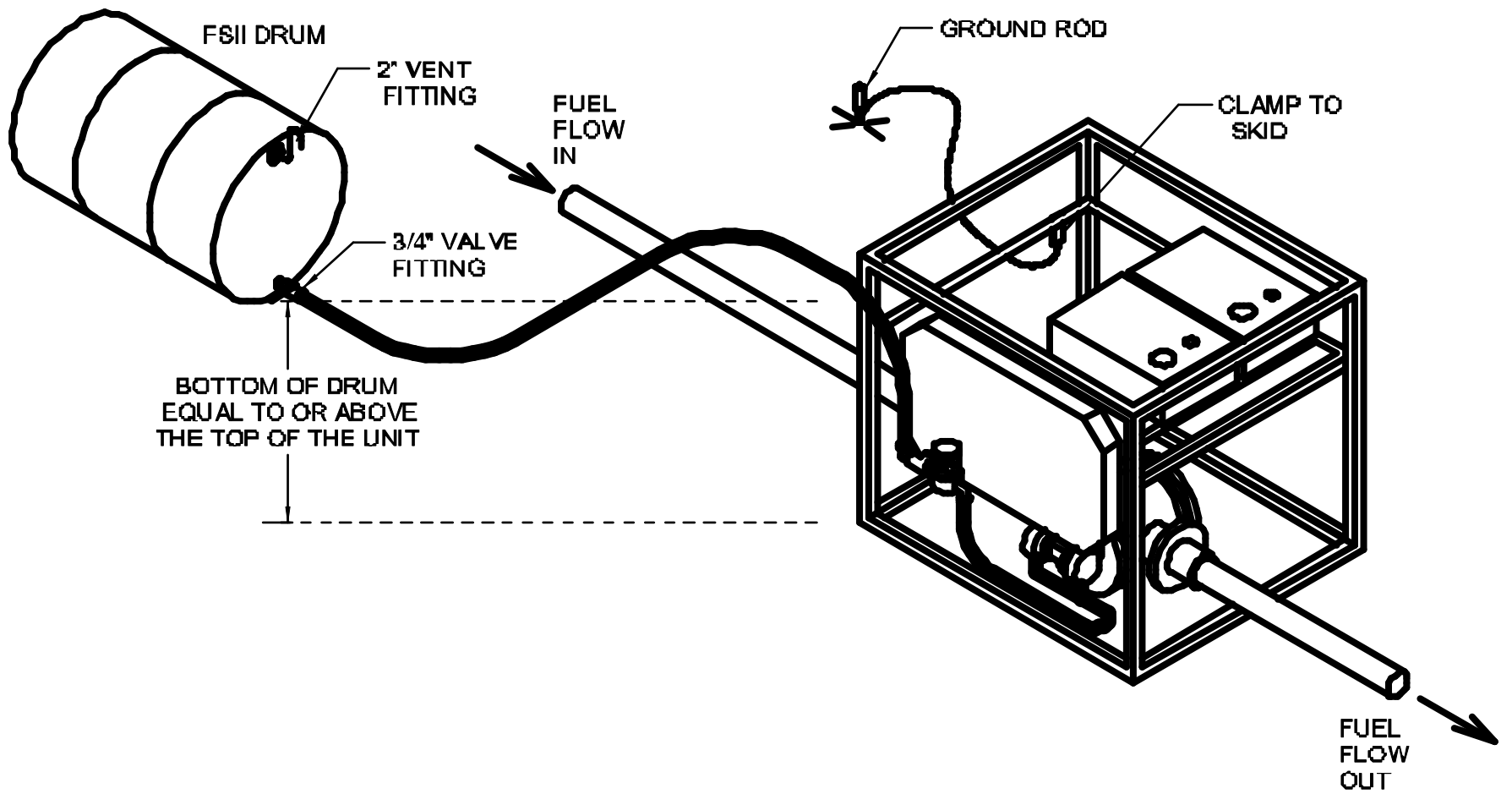

TYPICAL SYSTEM LAYOUT

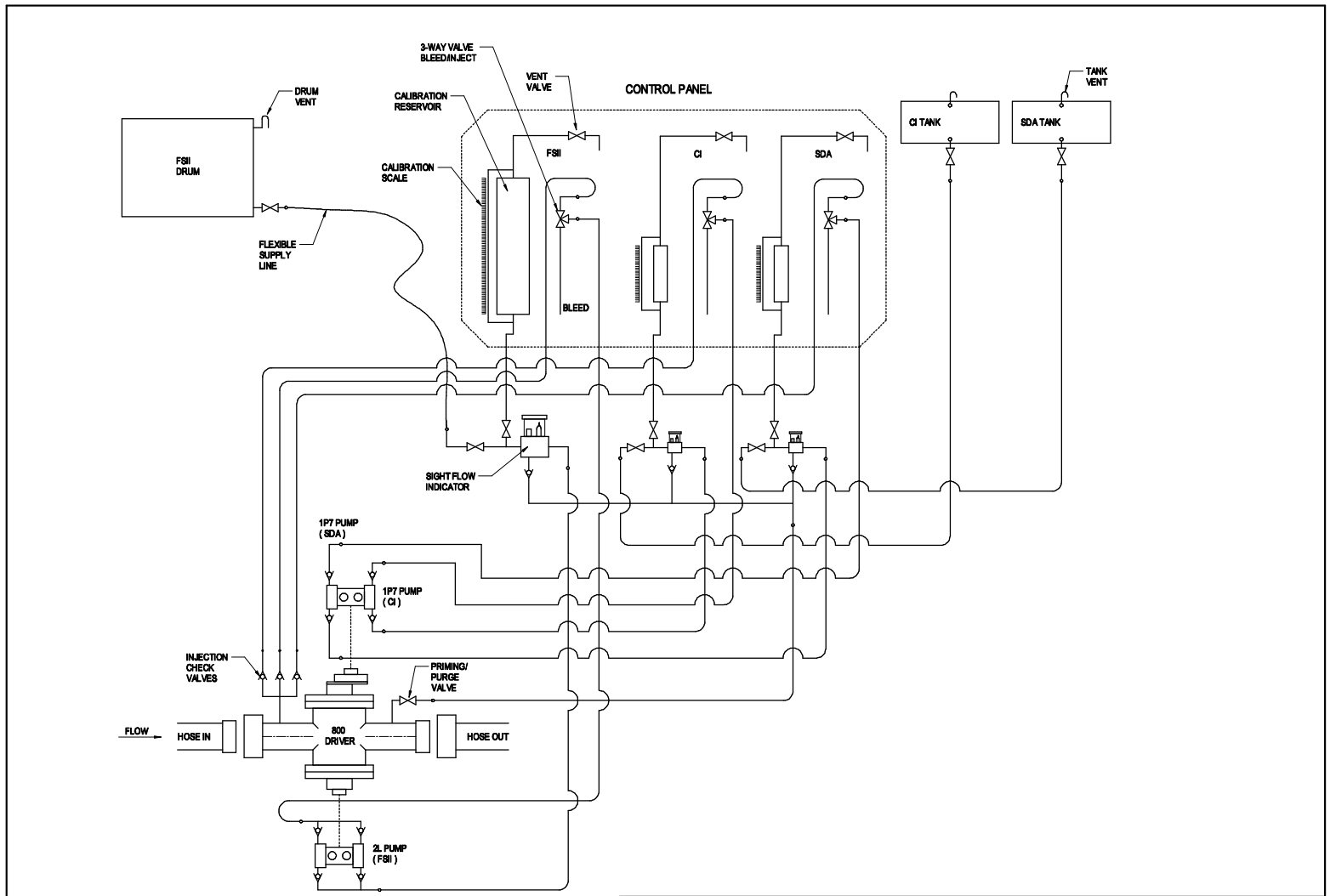

<p>*TOLERANCES* ALL DIMENSIONS ARE IN INCHES UNLESS OTHERWISE SPECIFIED.</p> <p>*TOL. - DECIMALS: .XXX= +/- .005 .XX= +/- .015 .X= +/- .030 FRAC.= 1/16</p> <p>*TOL. ANGLES: +/- .5 DEGREES</p> <p>*CONCENTRICITY: .005 T. I. R.</p> <p>*REMOVE BURRS AND BREAK EDGES .005 MIN.</p>				<p>THIS PRINT IS CONFIDENTIAL AND IS THE PROPERTY OF HAMMONDS TECHNICAL SERVICES</p> <p>THIS PRINT SHALL NOT BE USED, COPIED OR REPRODUCED IN WHOLE OR IN PART NOR SHALL THE CONTENTS BE REVEALED IN ANY MANNER TO WHOMEVER WITHOUT WRITTEN PERMISSION IS OBTAINED FROM HAMMONDS TECHNICAL SERVICES.</p>		<p>HAMMONDS TECHNICAL SERVICES, INC.</p> <p>SCALE: NTS APPROVED PART NUMBER: .</p> <p>DATE: 07/22/13 DRAWN BY: SS</p> <p>REVISED: -</p>															
<table border="1"> <thead> <tr> <th>DRAWING</th> <th>LEVELS</th> <th>VIEW</th> </tr> </thead> <tbody> <tr> <td>1707</td> <td>146, 147</td> <td>I</td> </tr> </tbody> </table>				DRAWING	LEVELS	VIEW	1707	146, 147	I	<table border="1"> <thead> <tr> <th>FROM SER#</th> <th>DATE</th> <th>TO SER#</th> <th>DATE</th> </tr> </thead> <tbody> <tr> <td>X</td> <td>X</td> <td>X</td> <td>X</td> </tr> </tbody> </table>		FROM SER#	DATE	TO SER#	DATE	X	X	X	X	<p>DRAWING TITLE: FLUID SCHEMATIC</p> <p>DRAWING NUMBER: 6916</p>	
DRAWING	LEVELS	VIEW																			
1707	146, 147	I																			
FROM SER#	DATE	TO SER#	DATE																		
X	X	X	X																		
<table border="1"> <thead> <tr> <th>NO.</th> <th>REVISION</th> <th>DATE</th> <th>BY</th> <th>APPVD</th> </tr> </thead> <tbody> <tr> <td>1</td> <td>INITIAL RELEASE</td> <td>07/22/13</td> <td>SS</td> <td>X</td> </tr> </tbody> </table>		NO.	REVISION	DATE	BY	APPVD	1	INITIAL RELEASE	07/22/13	SS	X	<p>800 DRIVER</p> <p>1P7 PUMP (SDA)</p> <p>1P7 PUMP (CI)</p> <p>2L PUMP (FSII)</p> <p>HOSE IN</p> <p>HOSE OUT</p> <p>INJECTION CHECK VALVES</p> <p>PRIMING/PURGE VALVE</p> <p>SIGHT FLOW INDICATOR</p> <p>BLEED</p> <p>VENT VALVE</p> <p>3-WAY VALVE BLEED/INJECT</p> <p>FLUID SCHEMATIC</p>		<p>TANK VENT</p> <p>SDA TANK</p> <p>CI TANK</p>							
NO.	REVISION	DATE	BY	APPVD																	
1	INITIAL RELEASE	07/22/13	SS	X																	